



User Manual

Model T640 PM Mass Monitor

© TELEDYNE API (TAPI)
9970 CARROLL CANYON ROAD
SAN DIEGO, CALIFORNIA 92131-1106
USA

Toll-free Phone: 800-324-5190
Phone: +1 858-657-9800
Fax: +1 858-657-9816
Email: api-sales@teledyne.com
Website: <http://www.teledyne-api.com/>

NOTICE OF COPYRIGHT

© 2016-2018 Teledyne Advanced Pollution Instrumentation. All rights reserved.

TRADEMARKS

All trademarks, registered trademarks, brand names or product names appearing in this document are the property of their respective owners and are used herein for identification purposes only.

SAFETY MESSAGES

Important safety messages are provided throughout this manual for the purpose of avoiding personal injury or instrument damage. Please read these messages carefully. Each safety message is associated with a safety alert symbol, and are placed throughout this manual; the safety symbols are also located inside the instrument. It is imperative that you pay close attention to these messages, the descriptions of which are as follows:



WARNING: Electrical Shock Hazard



HAZARD: Strong oxidizer



GENERAL WARNING/CAUTION: Read the accompanying message for specific information.



CAUTION: Hot Surface Warning



Do Not Touch: Touching some parts of the instrument without protection or proper tools could result in damage to the part(s) and/or the instrument.



Technician Symbol: All operations marked with this symbol are to be performed by qualified maintenance personnel only.



Electrical Ground: This symbol inside the instrument marks the central safety grounding point for the instrument.

CAUTION



This instrument should only be used for the purpose and in the manner described in this manual. If you use this instrument in a manner other than that for which it was intended, unpredictable behavior could ensue with possible hazardous consequences.

NEVER use any TAPI analyzer to sample combustible gas(es)!

For Technical Assistance regarding the use and maintenance of this instrument or any other Teledyne API product, contact Teledyne API's Technical Support Department:

Telephone: 800-324-5190

Email: sda_techsupport@teledyne.com

or access any of the service options on our website at <http://www.teledyne-api.com/>

CONSIGNES DE SÉCURITÉ

Des consignes de sécurité importantes sont fournies tout au long du présent manuel dans le but d'éviter des blessures corporelles ou d'endommager les instruments. Veuillez lire attentivement ces consignes. Chaque consigne de sécurité est représentée par un pictogramme d'alerte de sécurité; ces pictogrammes se retrouvent dans ce manuel et à l'intérieur des instruments. Les symboles correspondent aux consignes suivantes:



AVERTISSEMENT : Risque de choc électrique



DANGER : Oxydant puissant



AVERTISSEMENT GÉNÉRAL / MISE EN GARDE : Lire la consigne complémentaire pour des renseignements spécifiques



MISE EN GARDE : Surface chaude



Ne pas toucher : Toucher à certaines parties de l'instrument sans protection ou sans les outils appropriés pourrait entraîner des dommages aux pièces ou à l'instrument.



Pictogramme « technicien » : Toutes les opérations portant ce symbole doivent être effectuées uniquement par du personnel de maintenance qualifié.



Mise à la terre : Ce symbole à l'intérieur de l'instrument détermine le point central de la mise à la terre sécuritaire de l'instrument.

MISE EN GARDE



Cet instrument doit être utilisé aux fins décrites et de la manière décrite dans ce manuel. Si vous utilisez cet instrument d'une autre manière que celle pour laquelle il a été prévu, l'instrument pourrait se comporter de façon imprévisible et entraîner des conséquences dangereuses.

NE JAMAIS utiliser un analyseur de gaz pour échantillonner des gaz combustibles!

WARRANTY

WARRANTY POLICY (02024J)

Teledyne API (TAPI), a business unit of Teledyne Instruments, Inc., provides that:

Prior to shipment, TAPI equipment is thoroughly inspected and tested. Should equipment failure occur, TAPI assures its customers that prompt service and support will be available. (For the instrument-specific warranty period, please refer to the “Limited Warranty” section in the Terms and Conditions of Sale on our website at: <http://www.teledyne-api.com>.)

COVERAGE

After the warranty period and throughout the equipment lifetime, TAPI stands ready to provide on-site or in-plant service at reasonable rates similar to those of other manufacturers in the industry. All maintenance and the first level of field troubleshooting are to be performed by the customer.

NON-TAPI MANUFACTURED EQUIPMENT

Equipment provided but not manufactured by TAPI is warranted and will be repaired to the extent and according to the current terms and conditions of the respective equipment manufacturer’s warranty.

PRODUCT RETURN

All units or components returned to Teledyne API should be properly packed for handling and returned freight prepaid to the nearest designated Service Center. After the repair, the equipment will be returned, freight prepaid.

The complete Terms and Conditions of Sale can be reviewed at <http://www.teledyne-api.com>

CAUTION – Avoid Warranty Invalidation



Failure to comply with proper anti-Electro-Static Discharge (ESD) handling and packing instructions and Return Merchandise Authorization (RMA) procedures when returning parts for repair or calibration may void your warranty. For anti-ESD handling and packing instructions please refer to the manual, Fundamentals of ESD, PN 04786, in its “Packing Components for Return to Teledyne API’s Customer Service” section. The manual can be downloaded from our website at <http://www.teledyne-api.com>; RMA procedures are under Return Authorization.

ABOUT THIS MANUAL

This user manual, part number 08354, provides instructions for the setup, installation, and operation of the T640 Real-time Continuous PM Monitor.

Support manuals, such as electrostatic discharge (ESD) prevention and various communications, are available on the TAPI website <http://www.teledyne-api.com> under Product Manuals.

We recommend that all users read this manual in its entirety before operating the instrument.

TABLE OF CONTENTS

Safety Messages.....	ii
WARRANTY.....	iv
About This Manual.....	v
Table of Contents.....	vi
List of Figures.....	vii
List of Tables.....	ix
1. INTRODUCTION, SPECIFICATIONS, APPROVALS, AND COMPLIANCE.....	10
1.1. Specifications.....	10
1.2. EPA Designation.....	11
1.3. Safety.....	11
1.4. EMC.....	12
2. INSTALLATION AND HARDWARE SETUP.....	12
2.1. Unpacking.....	12
2.1.1. List of Standard Items.....	13
2.1.2. List of Optional Accessories.....	13
2.1.3. Ventilation Clearance.....	16
2.2. Instrument Layout.....	16
2.2.1. Front Panel.....	16
2.2.2. Rear Panel.....	17
2.2.3. Internal Layout.....	18
2.2.4. Height Dimensions.....	19
2.3. Connections and Startup.....	20
2.3.1. Power Connection.....	20
2.3.2. Communications Interface Connections.....	21
2.3.3. Aerosol Sample Conditioner (ASC) Connections and Installation.....	21
2.3.4. Inlet Installation.....	25
2.4. Indoor/Outdoor Installation.....	27
2.4.1. Shelter Installation with Roof Penetration.....	27
2.4.2. Outdoor Enclosure Installation.....	31
2.5. Pneumatics.....	33
2.6. Display and Menu Navigation.....	35
2.7. Startup and Functional Checks.....	36
2.7.1. Startup.....	36
2.7.2. Functional Checks of Operating Parameters.....	36
2.7.2.1. Initial Sensor Checks and Adjustments.....	37
3. SOFTWARE SETUP AND OPERATION.....	37
3.1. Menu System Overview.....	37
3.2. Configuration and Setup.....	38
3.2.1. HomeScreen.....	38
3.2.2. Dashboard.....	39
3.2.3. Alerts.....	40
3.2.4. Utilities>Datalog View.....	40
3.2.5. Utilities>Alerts Log.....	40
3.2.6. Utilities>USB Utilities (Downloads and Updates).....	41
3.2.6.1. Downloading DAS (Data Acquisition System) Data.....	42
3.2.6.2. Updating Software/Firmware.....	42
3.2.6.3. Transferring Configuration to Other Instruments.....	44
3.2.6.4. Generating a Report.....	45
3.2.7. Setup>Data Logging.....	45
3.2.7.1. Creating a User-Defined Data Log.....	46
3.2.7.2. Configuring Trigger Types.....	47
3.2.7.3. Downloading DAS (Data Acquisition System) Data.....	48
3.2.8. Setup>Events.....	49
3.2.8.1. Creating User-Defined Events.....	50

3.2.8.2. Editing or Deleting Events	51
3.2.9. Setup>Dashboard	51
3.2.10. Setup>VARS (Variables)	52
3.2.11. Setup>Homescreen	53
3.2.12. Setup>Instrument.....	54
3.2.12.1. Instrument Display Calibration (for Earlier Instruments)	54
3.2.12.2. Instrument Date/Time Adjustments	56
3.2.13. Setup>Comm (Communications Setup)	57
3.2.13.1. TCP Port1	57
3.2.13.2. TCP Port2	57
3.2.13.3. Network Settings	59
3.3. Operation.....	60
4. SENSOR CHECKS AND ADJUSTMENTS	60
4.1. Ambient Temperature Sensor Check.....	61
4.2. Pressure Sensor Check and Calibration	62
4.3. Sample Flow Cal (5-LPM)	63
4.4. Bypass Flow Cal (11.67-LPM)	64
4.5. PMT Adjustment.....	65
4.6. Leak Check	67
5. MAINTENANCE AND SERVICE	68
5.1. Maintenance Schedule.....	68
5.2. Maintenance Procedures	69
5.2.1. Cleaning the T640 Inlet.....	69
5.2.2. Cleaning the US EPA PM10 Inlet	70
5.2.3. Changing the Disposable Filter Unit (DFU)	71
5.2.4. Checking Pump Performance	72
5.2.5. Checking the Volume Flow	72
5.2.6. Cleaning the Optical Chamber and the RH/T Sensor.....	73
5.2.7. Inspecting the Sampling Line.....	78
5.2.8. Checking for Leaks	78
5.3. Troubleshooting and Service	79
5.3.1. Fault Diagnosis	79
5.3.2. Flow Problems	80
5.3.3. Calibration Problems.....	80
5.3.4. Technical Assistance	81
6. PRINCIPLES OF OPERATION	81
6.1. Sampling System	82
6.1.1. Inlet	82
6.1.2. Aerosol Sample Conditioner (ASC)	82
6.1.3. Optical particle Sensor.....	82
6.1.4. Flow Sensor and Pump Control.....	82
6.2. Electronic Block Diagram	83
APPENDIX A – Warranty Repair Questionnaire	84
APPENDIX B – Menu Hierarchy	86

LIST OF FIGURES

Figure 2-1. T640 Typical Set of Included Hardware	14
Figure 2-2. 640x Option Typical Set of Included Hardware	15
Figure 2-3. Front Panel Layout	16
Figure 2-4. T640 Rear Panel.....	17
Figure 2-5. T640 with 640x Option Rear Panel.....	17
Figure 2-6. T640 Internal Layout, with 640x Option Components	18

Figure 2-7. Top View of Inlet Nozzle.....	21
Figure 2-8. Inlet Nozzle Adapter for ASC Connection	22
Figure 2-9. Collar for Lower Flange	22
Figure 2-10. Set Screws for ASC	23
Figure 2-11. Collar and ASC Adapter Support.....	23
Figure 2-12. Ambient Temperature Probe and ASC Connections (T640 with 640X Option shown).....	24
Figure 2-13. T640 Sample Head (5-LPM) and ASC Assembly	25
Figure 2-14. 640X Option Inlet and ASC Assembly.....	26
Figure 2-15. Ambient Temperature Sensor Probe Installed into Radiation Shield	26
Figure 2-16. T640 Inlet Tube and Slip Coupler Assembly	28
Figure 2-17. 640x Inlet Tube and Slip Coupler Assembly	29
Figure 2-18. T640 Inlet and Sample Line Assembly.....	29
Figure 2-19. 640x Inlet and Sample Line Assembly	30
Figure 2-20. T640 Rooftop Sample Inlet and Extension Tubing Installation	30
Figure 2-21. T640 (left) and 640x (right) Outdoor Enclosures Assembled	32
Figure 2-22. T640 Pneumatics.....	33
Figure 2-23. T640 with 640X Option Pneumatics	34
Figure 2-24. Sample Home Screen with Orientation	35
Figure 2-25. Concentration Graph and Meter Graph.....	36
Figure 3-1. Home Configuration thru Home Page Shortcut.....	39
Figure 3-2. Dashboard	39
Figure 3-3. Alerts Log.....	40
Figure 3-4. USB Utility Pages	41
Figure 3-5: Das download Page	42
Figure 3-6: Remote Update Page.....	43
Figure 3-7: Manual Update Page (and other utilities).....	43
Figure 3-8: Configuration Transfer	44
Figure 3-9: Report Generation Page	45
Figure 3-10. Datalog Configuration, New Log Page	45
Figure 3-11. Datalog Configuration, Existing Log	46
Figure 3-12. Creating a New Data Log	46
Figure 3-13. Datalog Periodic Trigger Configuration	47
Figure 3-14. Datalog - Conditional Trigger Configuration	48
Figure 3-15. DAS Data Utility	48
Figure 3-16. Events Page	49
Figure 3-17. Event Configuration	50
Figure 3-18. Existing Event for Viewing or Editing.....	51
Figure 3-19. Dashboard Configuration.....	51

Figure 3-20. VARS Configuration Page	52
Figure 3-21. Home Configuration thru Setup Menu	53
Figure 3-22. Touchscreen Calibration Page	54
Figure 3-23. Date and Time Configuration Page	56
Figure 3-24. Communications Configuration, Network Settings	59
Figure 4-1. Leak-Check/Flow-Audit Adaptor Kit.....	61
Figure 4-2. Pressure Cal Menu	62
Figure 4-3. Sample Flow Cal Menu	63
Figure 4-4. Bypass Flow Cal Menu.....	64
Figure 4-5. PMT Adjustment Menu	65
Figure 4-6. Leak Check Menu.....	67
Figure 5-1. T640 Inlet (standard)	69
Figure 5-2. 640X Option Disassembly	70
Figure 5-3. Opening the Front Panel	71
Figure 5-4. Internal DFU	71
Figure 5-5. External DFU, (with 640X Option only)	72
Figure 5-6. Maintenance: Optics Chamber Windows	76
Figure 5-7. Maintenance: Final Dusting	76
Figure 6-1. T640 with 640X Option Electronic Block Diagram.....	83

LIST OF TABLES

Table 1-1. Specifications.....	10
Table 2-1. Ventilation Clearance.....	16
Table 3-1. Setup>Instrument Menu	54
Table 3-2. T640 MODBUS Register	57
Table 3-3. LAN/Ethernet Configuration Properties	59
Table 5-1. Maintenance Schedule	68
Table 5-2. Alerts and Recommendations.....	79

Appendix A: Warranty Repair Questionnaire

Appendix B: Menu Hierarchy

1. INTRODUCTION, SPECIFICATIONS, APPROVALS, AND COMPLIANCE

The Teledyne API Model T640 with 640X Option is a real-time, continuous particulate matter (PM) mass monitor that uses scattered light spectrometry for measurement. The T640 measures 2.5 PM, and the 640X Option measures 2.5, 10, and coarse PM.

1.1. SPECIFICATIONS

Table 1-1 presents the T640 PM Mass Monitor specifications.

Table 1-1. Specifications

PARAMETER	SPECIFICATION	
Measurement Principle	90° white-light scattering	
Light Source	Polychromatic LED	
Particle Size Resolution	0.18 – 20µm over 256 channels, combined to 64 channels for mass calculation	
PM Mass Resolution Measurement Range	0.1 – 10,000 µg/m ³	
Mass Measurement & Display Resolution	0.1 µg/m ³	
Precision	+/- 0.5 µg/m ³ (1-hr average)	
Lower Detectable Limit	< 0.1 µg/m ³ (1-hr average)	
Mass Concentration Accuracy	T640 Exceeds US EPA Class III PM2.5 640X Option Exceeds US EPA US EPA PM10 FEM and Class III PM2.5 & PM10-2.5 FEM performance requirements for additive and multiplicative bias compared to FRM samplers	
Flow Rate	T640 5.0-LPM 640X Option 5.0-LPM + 11.67-LPM bypass flow	
Flow Accuracy	Within +/-1%; (Typically within +/- 0.5%)	
AC Power	Rating	Typical Power Consumption
Instrument	110-120 V, 60 Hz 3.0 A	<120 W (at 120 VAC)
	220V-240V, 50/60 Hz 3.0 A	<120 W (at 120 VAC)
External pump (640X Option only)	110-120 V, 60 Hz 3.0 A	<360 W (at 120 VAC)
	220V-240V, 50/60 Hz 3.0 A	<360 W (at 120 VAC)
Communication	1 Ethernet: 10/100Base-T (supports MODBUS and HTTP polling protocols) 2 USB device ports	
Data Storage	4 Gb memory allows for >1 year of data storage Minimum Resolution (data rate): 10 seconds, user-definable	

PARAMETER	SPECIFICATION
Dimensions	H x W x D: 7" x 17" x 14" (178 x 432 x 356 mm)
ASC (heater tube)	43" (1092 mm) above the lid
ASC w/T640 inlet	53.5" (1359 mm) above the lid
ASC w/640X Option inlet	70" (1778 mm) above the lid
Optional external shelter	HxWxD: 45" x 25" x 25" (1143 x 635 x 635 mm)
Weight	19 lbs (8.6 kg) w/ T640 ASC + inlet 27 lbs (12.2 kg); w/ 640X Option ASC + inlet 30 lbs (13.6 kg)
Operating Conditions	
Operating temperature	0 - 50°C, non-condensing
Ambient temperature	-40 - 60°C
Ambient Relative Humidity	0 - 100%
Sample Humidity Control	Aerosol Sample Conditioner (ASC) 24VDC 90W (max) heater controlled to 35% RH
Environmental Conditions	Installation Category (Over voltage Category) II Pollution Degree 2 For outdoor use only, to ≤ 5000 m altitude
¹ As defined by the US EPA	² At constant temperature and pressure

1.2. EPA DESIGNATION

TAPI's Model T640 PM Mass Monitor and its options are officially designated as US EPA Federal Equivalent Methods (FEMs) for determining compliance with particulate matter mass concentration National Ambient Air Quality Standards (NAAQS). The US EPA designation numbers are as follows:

5.0 LPM Model T640 monitor (PM2.5)	EQPM-0516-236
16.7 LPM Model T640 with 640X option monitor (PM2.5)	EQPM-0516-238
16.7 LPM Model T640 with 640X option monitor (PM10-2.5)	EQPM-0516-240
16.7 LPM Model T640 with 640X option monitor (PM10)	EQPM-0516-239

The official List of Designated Reference and Equivalent Methods is published in the U.S. Federal Register: <http://federalregister.gov/a/2016-16578>.

Comply with Code of Federal Regulations, Title 40 (downloadable from the U.S. Government Publishing Office at <http://www.gpo.gov/fdsys/>) and with Quality Assurance Guidance documents (available on the EPA website, <http://www.epa.gov/ttn/amtic/qalist.html>). Give special attention to specific regulations regarding methods for determining particulate matter.

1.3. SAFETY

IEC/EN 61010-1:2010 (3rd Edition), Safety requirements for electrical equipment for measurement, control, and laboratory use.

CE: 2006/95/EC, Low-Voltage Directive

1.4. EMC

IEC/EN 61326-1, Class A Emissions/Industrial Immunity

EN55011 (CISPR 11), Group 1, Class A Emissions

FCC 47 CFR Part 15B, Class A Emissions

CE: 2004/108/EC, Electromagnetic Compatibility Directive

2. INSTALLATION AND HARDWARE SETUP

This section addresses the procedures for unpacking the instrument and inspecting for damage, presents clearance specifications for proper ventilation, and shows the instrument layout.

2.1. UNPACKING

Verify that there is no apparent external shipping damage. If damage has occurred, please advise the shipper first, then contact Teledyne API.

Included with your instrument is a printed record of the final performance characterization performed on your instrument at the factory. This record, titled T640/640x Mass Monitor Test Data Sheet, is an important quality assurance and calibration record and should be placed in the quality records file for this instrument.



WARNING – ELECTRICAL SHOCK HAZARD

Never disconnect PCAs, wiring harnesses or electronic subassemblies while under power.

With no power to the unit, carefully remove the top cover of the instrument and check for internal shipping damage by carrying out the following steps:

1. Carefully remove the top cover and check for internal shipping damage.
 - a. Remove the cover screws located on the sides of the instrument.
 - b. Slide the cover backward until it clears the instrument's front bezel.
 - c. Lift the cover straight up.
2. Inspect the interior to ensure all circuit boards and other components are intact and securely seated.
3. Check the connectors of the various internal wiring harnesses and pneumatic hoses to ensure they are firmly and securely seated.
4. Using the paperwork accompanying the instrument, verify that all of the standard and optional hardware ordered with the unit has been installed. These are listed on the paperwork accompanying the instrument.

2.1.1. LIST OF STANDARD ITEMS

- Model T640 Instrument with power cord and Test Data Sheet:
- SpanDust™ bottle with calibration certificate
- Aerosol Sample Conditioner (ASC) Tube (~43" long)
- Ambient Temperature Sensor Cable (25') with radiation shield and mounting bracket
- Internal Temperature Sensor Cable (4') – for performing flow sensor calibrations from inside shelter without having to disconnect the normally installed ambient temperature sensor cable
- CD with operating manuals

2.1.2. LIST OF OPTIONAL ACCESSORIES

- Sample head, 5LPM (for T640 base model; PM2.5 FEM)
 - Sample Head
 - Water collection jar
 - ~6" upper inlet tube
- T640 base model extension tube kit
 - 8' long aluminum tube (5/8" OD) with locking collar
 - Roof flange with 5/8" cord grip and 1/4" cord grip (for ambient temp sensor cable)
 - Slip coupler (5/8" ID)
- 640x option
 - US EPA PM10 inlet, 16.7 LPM
 - Outer extension tube (~12" length)
 - Inner extension tube (~8" length)
 - External vacuum pump pack, 120 or 220V AC with tubing
 - Bypass flow splitter / adapter (usually pre-installed onto the ASC from the factory)
 - 1/4" black bypass flow tubing
- 640x extension tube kit
 - 8' long aluminum tube (1" OD)
 - Step down adapter (1 1/4" ID to 1" ID)
 - Slip coupler (1" ID)
 - Roof flange with 1" cord grip and 1/4" cord grip (for ambient temp sensor cable)
 - Slip coupler (5/8" ID, 1 1/4" OD)
- Support tripod with cord grips for 5/8" or 1" OD tubes
- Leak check / flow audit adapter kit



Figure 2-1. T640 Typical Set of Included Hardware



Figure 2-2. 640x Option Typical Set of Included Hardware

2.1.3. VENTILATION CLEARANCE

Whether the Monitor is set up on a bench or installed in an instrument rack, be sure to leave sufficient ventilation clearance.

Table 2-1. Ventilation Clearance

AREA	MINIMUM REQUIRED CLEARANCE
Back of the instrument	10 cm / 4 in
Sides of the instrument	2.5 cm / 1 in
Above and below the instrument	2.5 cm / 1 in

2.2. INSTRUMENT LAYOUT

2.2.1. FRONT PANEL

Figure 2-3 shows the front panel layout, which has the display screen, two USB ports for peripheral device connections: mouse and keyboard as alternatives to the touchscreen interface, or flash drive for uploads/downloads (devices not included).

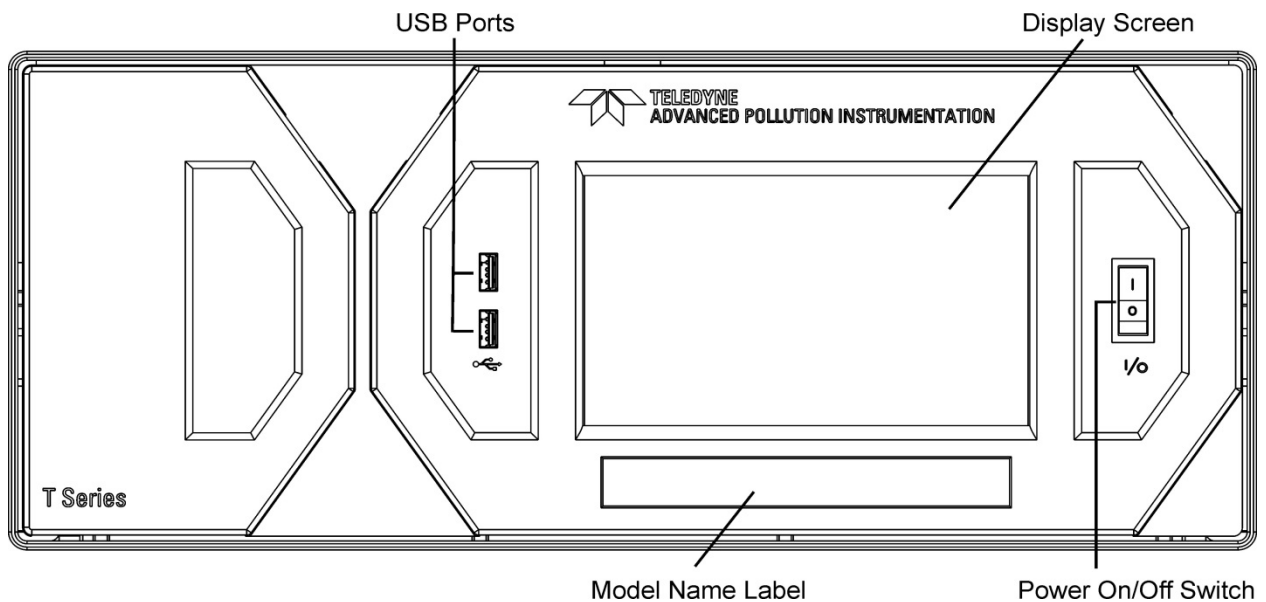

Figure 2-3. Front Panel Layout

2.2.2. REAR PANEL

The rear panel shows fittings and connectors for the monitor's functions as well as connectors for communication.

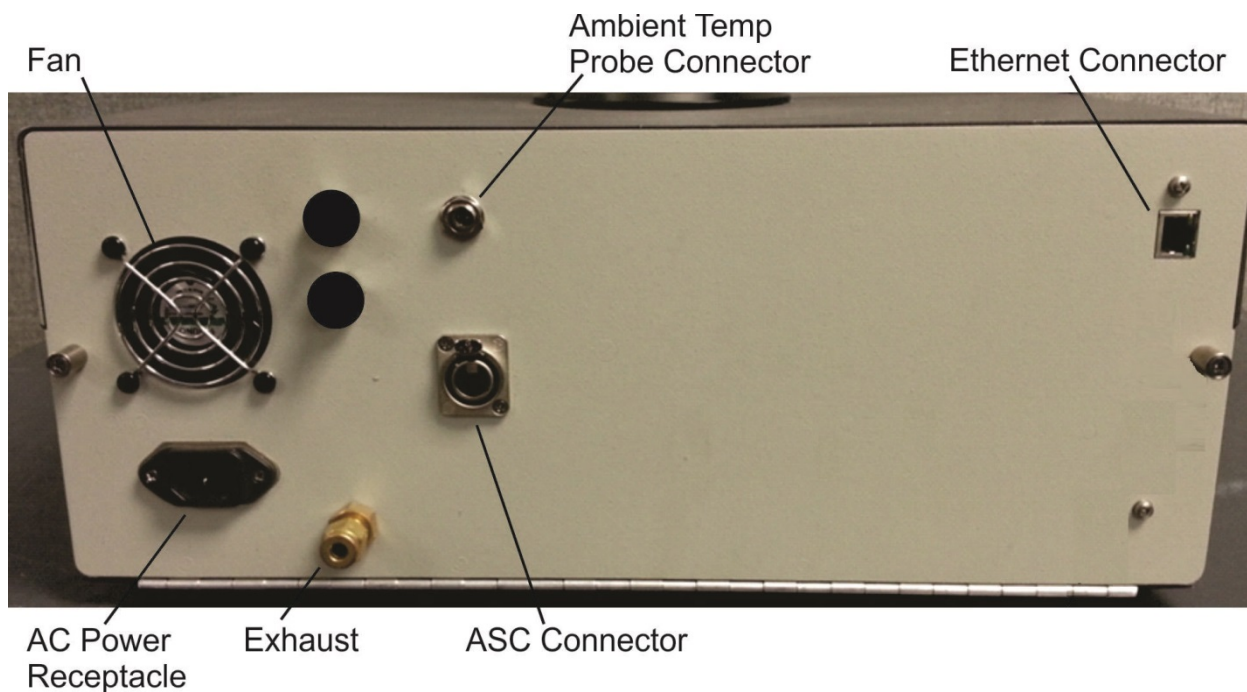

Figure 2-4. T640 Rear Panel

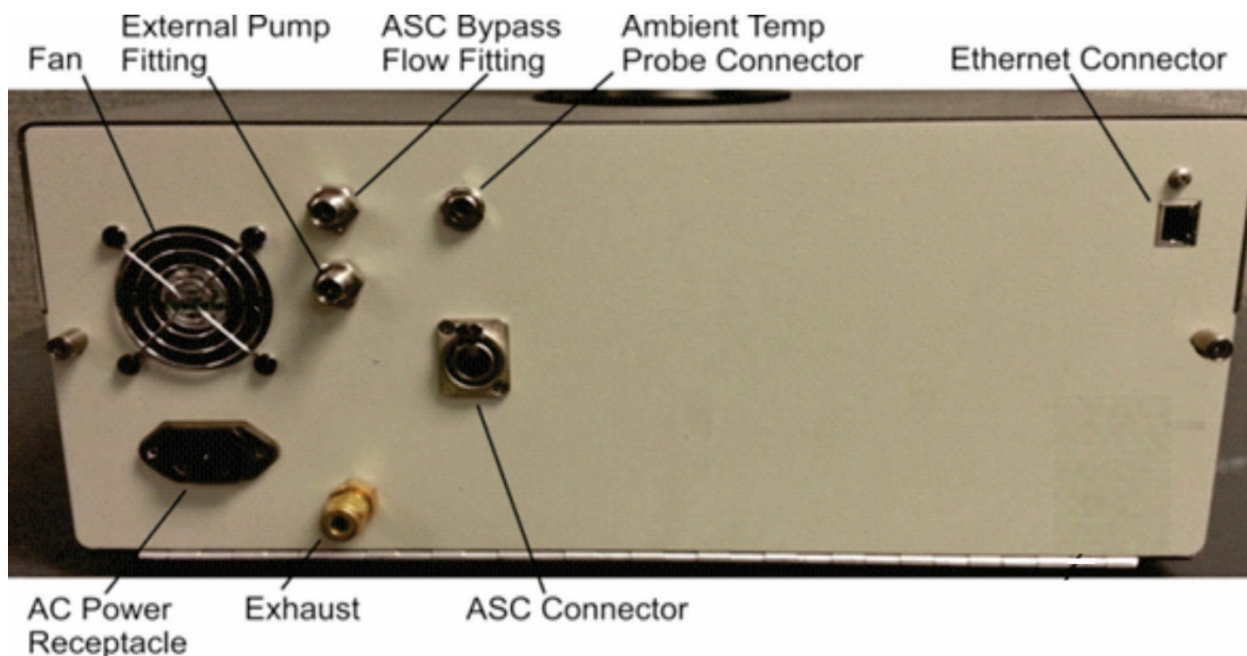

Figure 2-5. T640 with 640x Option Rear Panel

2.2.3. INTERNAL LAYOUT

Below shows the main components and assemblies of the monitor.

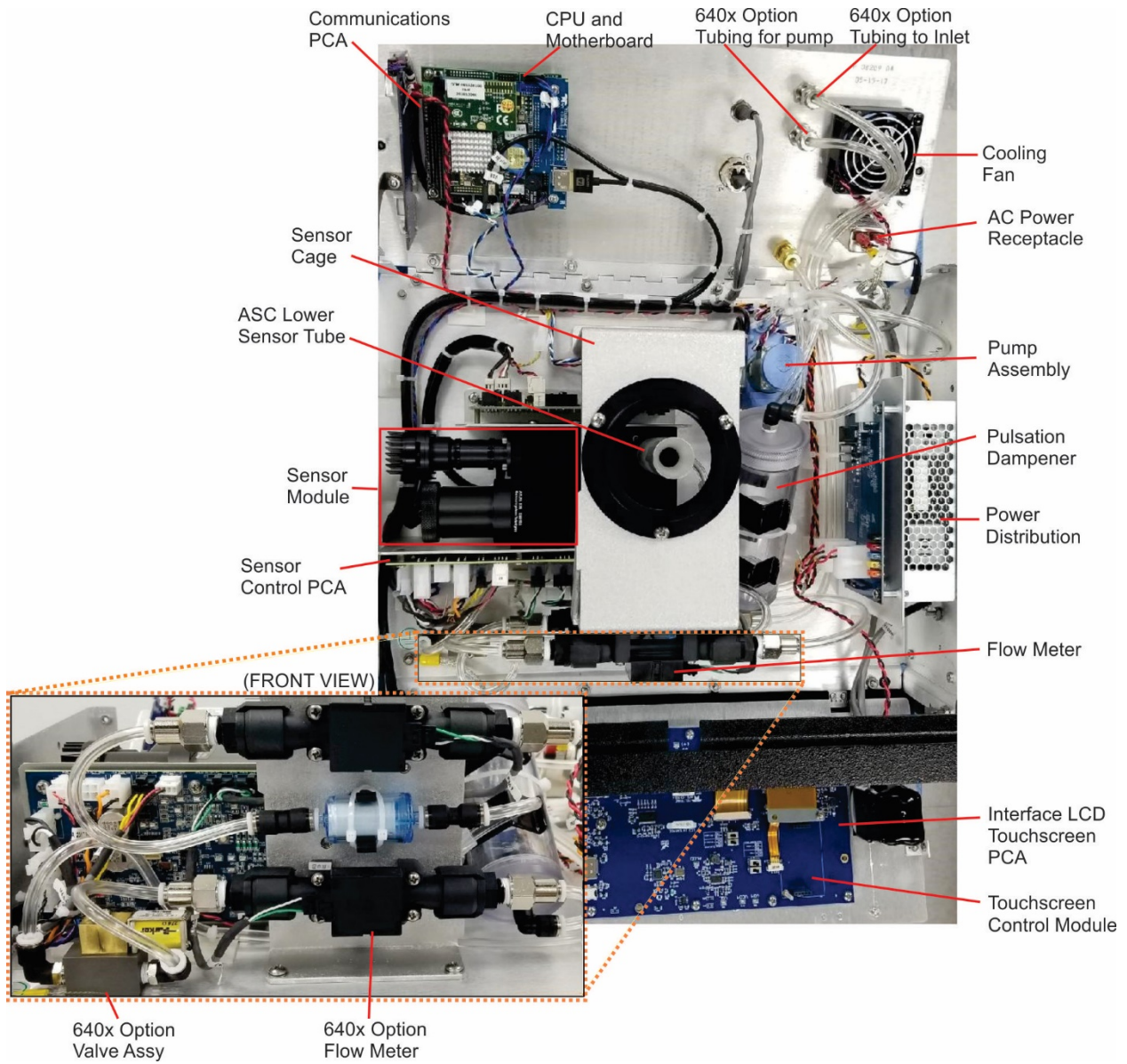

Figure 2-6. T640 Internal Layout, with 640x Option Components

2.2.4. HEIGHT DIMENSIONS

T640:



640x:

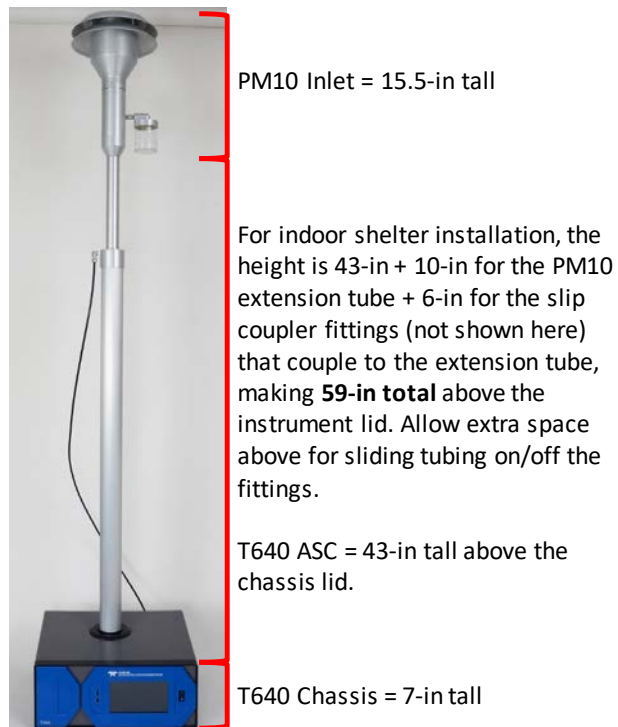

2.3. CONNECTIONS AND STARTUP

This section presents the various connections for setup and preparing the instrument for operation (Section 2.6).

WARNING: ELECTRICAL SHOCK HAZARD



- High Voltages are present inside the instrument.
- Ensure that the power cord being used is capable of carrying the power rating of the instrument (see rear panel label).
- Power connection must have functioning ground connection.
- Do not defeat the ground wire on power plug.
- Turn off instrument power before disconnecting or connecting electrical subassemblies.
- Do not operate with cover off.

CAUTION – AVOID DAMAGE TO THE INSTRUMENT



Do not operate under conditions outside the environmental specifications. Operating this instrument under different environmental conditions, such as corrosive or explosive environments, electric or electromagnetic fields, areas of ionizing radiation, or areas conducive to shock or vibration, could damage or destroy the instrument.

CAUTION – AVOID DAMAGE TO THE INSTRUMENT



Ensure that the AC power voltage matches the voltage indicated on the instrument's model/specs label before plugging it into line power.

Note

To maintain compliance with EMC standards, any cable length must be no greater than 3 meters for all communication connections.

2.3.1. POWER CONNECTION

Adhering to the warning messages previously introduced (Section 2.3), insert the power cord between the instrument's AC power connector and a properly rated power outlet.

2.3.2. COMMUNICATIONS INTERFACE CONNECTIONS

For network or Internet communication with the instrument, connect an Ethernet cable from the analyzer's rear panel Ethernet interface connector to an Ethernet port. Although the analyzer is shipped with DHCP enabled by default, it should be manually assigned a static IP address. See Section 3.2.13. The USB ports are for other utilities described later in this manual.

2.3.3. AEROSOL SAMPLE CONDITIONER (ASC) CONNECTIONS AND INSTALLATION

The ASC requires an inlet nozzle adapter for installation.

IMPORTANT

IMPACT ON READINGS OR DATA

The black inlet nozzle to the optical sensor is specific to the instrument and is not interchangeable with other T640 instruments. Use caution when handling and contact TAPI Tech Support if this piece is ever damaged as it could affect the instrument's performance.



Figure 2-7. Top View of Inlet Nozzle

1. Slide the aluminum adapter over the black inlet nozzle, ensuring its base is flush with the top of the optical sensor.

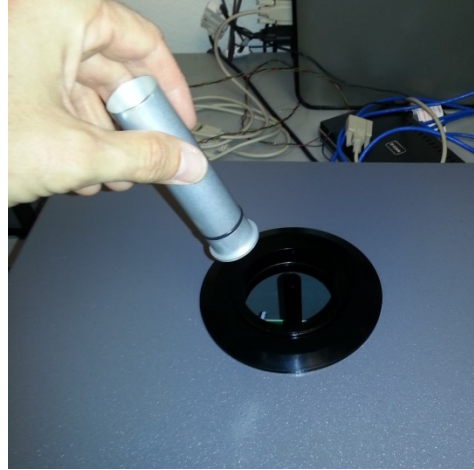

Figure 2-8. Inlet Nozzle Adapter for ASC Connection

2. Remove collar from lower flange of the instrument as shown:



Figure 2-9. Collar for Lower Flange

3. Identify the three openings on the lower flange ASC support and insert set screws on them. Use a 1/16" Hex/Allen Wrench. **Do not tighten them at this point.**

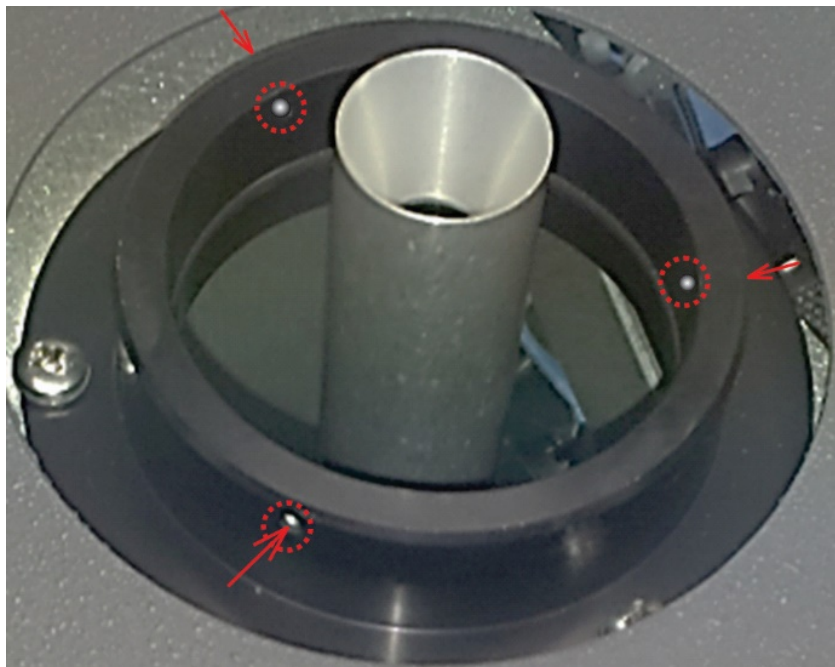

Figure 2-10. Set Screws for ASC

4. Replace collar over lower flange/ASC support:

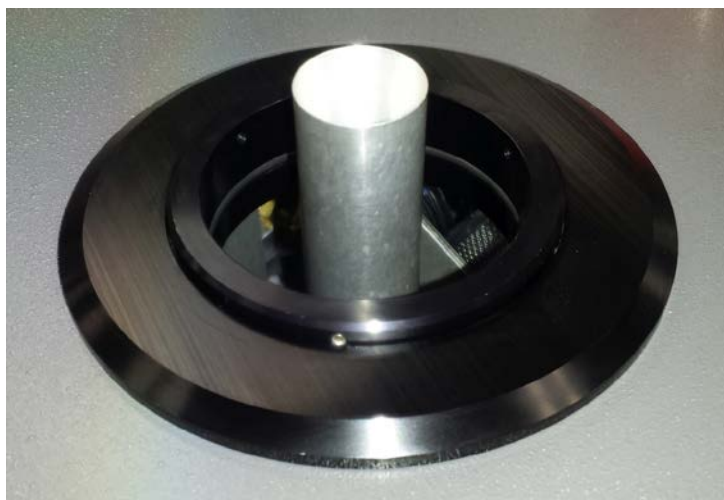

Figure 2-11. Collar and ASC Adapter Support

5. Carefully place ASC over sample inlet making sure it properly seated by applying sufficient pressure to slide past the internal o-rings at the base of the inlet nozzle adapter. Be sure the ASC is oriented squarely, by using a plumb bob or level:

6. Once the ASC is leveled, set screws should be hand tightened until snug. **Do not over-tighten; the screws should be relatively easy to loosen when necessary.** Press slightly on instrument top cover to allow more clearance if needed. **Do not use thread locker.**



7. Connect the ASC power and communications cable to the rear panel of the T640 labeled ASC Connector (or IADS Connector in some cases).
8. Locate the 25' temperature sensor cable (15' in some cases). Plug the ambient temperature probe connector into its respective rear panel electrical port.

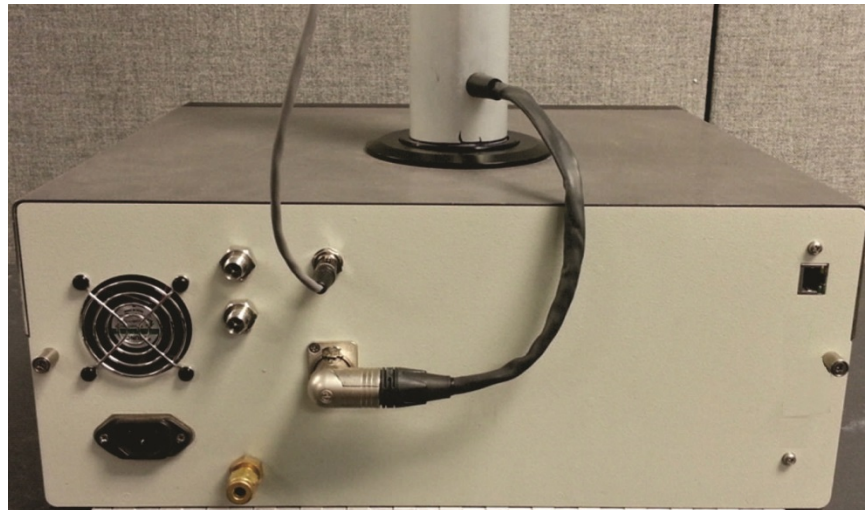

Figure 2-12. Ambient Temperature Probe and ASC Connections (T640 with 640X Option shown)

2.3.4. INLET INSTALLATION

1. To complete the installation now will depend on whether the instrument is being installed in an Outdoor Enclosure or Walk-in Shelter. If performing testing in a laboratory, you can proceed with attaching the inlet.
2. For the T640, assemble the inlet and the ASC as depicted below (Figure 2-13. T640 Sample Head (5-LPM) and ASC Assembly).

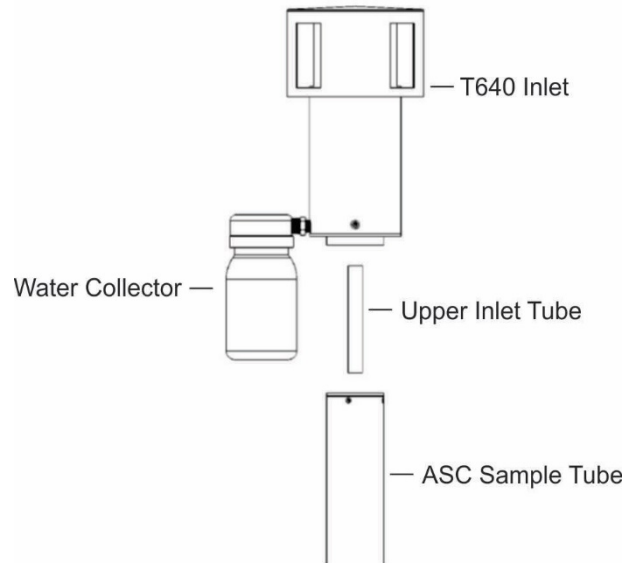

Figure 2-13. T640 Sample Head (5-LPM) and ASC Assembly

- For the T640 with 640x option, assemble the inlet parts together ensuring all connections fit snugly with no gaps.

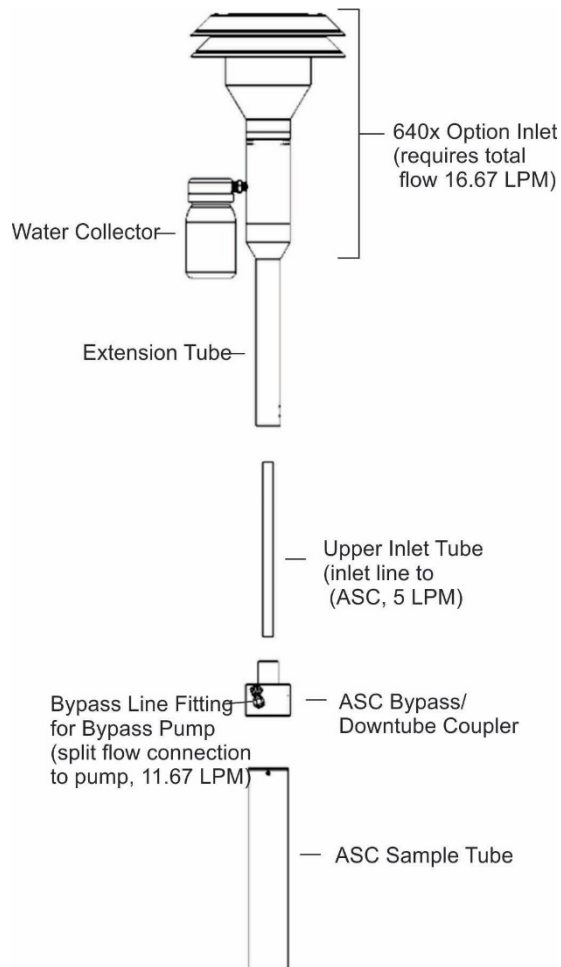

Figure 2-14. 640X Option Inlet and ASC Assembly



Figure 2-15. Ambient Temperature Sensor Probe Installed into Radiation Shield

- Route probe outside and insert into solar shield, ensuring solar shield maintains vertical orientation.

2.4. INDOOR/OUTDOOR INSTALLATION

The T640 can be installed in an indoor or outdoor shelter with roof penetration or in an outdoor enclosure. You may wish to watch an installation video, available at <https://www.youtube.com/watch?v=8H5NmNgBg1M> (or search youtube T640 rooftop installation). Also review Figure 2-7 through Figure 2-15 in the preceding sections as well as Figure 2-20 through Figure 2-21 for the instructions in this section.

2.4.1. SHELTER INSTALLATION WITH ROOF PENETRATION

1. Determine the location at which the T640 will operate in the shelter.
 - The instrument should be in a location where the top of the ASC will be no less than two feet from the top of the ceiling/roof line or,
 - The instrument should be placed at a height within the shelter so that after the ASC and 8' extension sample line are installed, the inlet (on top of the 8' extension sample line) is 2-m above the roof and equal height with any other PM instrument inlets. (In situations where the extension tube is too long, it can be cut to proper length).
2. Drill a hole in the roof to accommodate the diameter of the 8' extension sample line (5/8" OD for the T640, and 1" OD for the 640x). A second hole can be drilled to accommodate the ambient temperature sensor cable (1/4") or it can be routed through a hole in a wall.
3. Install the provided roof flange over the drilled sample tube hole and repeat with the 1/4" hole, if present.
 - Make sure to use good quality roof sealant for the base of the roof flange to ensure weather tightness and to prevent any leaks into the shelter.
4. Without locking it down, setup the sample line tripod so that its sample line hole aligns with the hole in the roof.
 - The tripod should be setup at such a height to properly support the sample line with the inlet on top.
5. Without the inlet installed on the top of the ASC, line up the instrument so that the opening at the top of the ASC is in-line with the sample line hole/roof flange on the shelter roof.

IMPORTANT

IMPACT ON READINGS OR DATA

Ensure that no debris enters the top of the ASC.

Note

The purpose of the Slip Coupler is to allow the extension tube to be disconnected from the instrument without disassembling the roof flange. With the Slip Coupler in the up position, the instrument can be moved forward or to the side for maintenance or verification procedures such as the PMT adjustment procedure described later in this manual. The Slip Coupler should be covering the junction of the two tubes during normal operation.

6. For the T640:

- a. At the top of the ASC, insert the ~6" 5/8"OD Upper Inlet Tube into the end of the ASC.
 - The Upper Inlet Tube should slide into the top of the ASC (about 2") and bottom out when completely inserted.
- b. Place the Slip Coupler on top of the Upper Inlet Tube until the tube is midway through the Slip Coupler.
- c. Slide the 8' sample line extension down through the tripod and the roof penetration until it meets the opening of the Slip Coupler. Slide the extension tube down into the Slip Coupler until it meets the Upper Inlet Tube so that the 5/8" tubes are flush within the Slip Coupler.
- d. Position the slip coupler so that the tubing is joined and centered over where the seam between the two tubes meet.

The following pictures demonstrate the steps of the installation:



Figure 2-16. T640 Inlet Tube and Slip Coupler Assembly

7. For the 640x:

- a. At the top of the ASC, insert the 11" long (5/8" OD) upper inlet tube into the ASC. Make sure to install with the tapered end facing up.
 - The upper inlet tube should slide into the top of the ASC (about 2") and bottom out when completely inserted.
- b. Place the 12" long, 1.25" OD extension tube over the upper inlet tube and seat onto the bypass flow coupler that is on the top of the ASC
- c. Place the 1.25" to 1" fitting on top of the 12" long extension tube (this coupler allows for usage of the 1" tube Slip Coupler)
- d. Slide the 1" OD sample line extension down through the tripod and the roof penetration until it meets the opening of the Slip Coupler. Slide the extension tube down into the Slip Coupler until it bottoms out on the tubing adapter.
- e. With the Slip Coupler all the way down, the seam between the extension tube and the adapter is in the middle of the Slip Coupler.

The following pictures demonstrate the steps of the installation:



Figure 2-17. 640x Inlet Tube and Slip Coupler Assembly

IMPORTANT

IMPACT ON READINGS OR DATA

Ensure that the sample line is vertically plumb to prevent any strain on the instrument and to prevent pneumatic leaks.

8. Lightly tighten the tripod cord grip and the roof flange cord grip around the sample line to hold it in place.
9. At the top of the sample line (on the roof), be sure the provided inlet locking collar is positioned 3" from the top of the sample line. This ensures the end of the inlet tube is in the proper position within the inlet when the inlet is put in place.
10. Ensure the locking collar set screw is tightened onto the inlet tube.
11. Place the inlet on top of the sample line.
 - Make sure the inlet is secure, i.e., that the collar holding it is not sliding.
 - Proper installation should have the inlet 2-m above the roof.

T640:



Figure 2-18. T640 Inlet and Sample Line Assembly

640x:



Figure 2-19. 640x Inlet and Sample Line Assembly

12. Connect the ambient temperature sensor cable to the rear panel of the instrument and route the other end out of the drilled hole (wall or roof), and extend it out near the instrument's inlet.
13. Install the radiation shield either onto the instrument sample tube or nearby guard rail using the supplied ratcheting ribbon.
14. Loosen the retention screw and insert the ambient temperature sensor probe into the bottom of the radiation shield. Position the end of the probe into the upper center portion of the radiation shield and tighten down on the retention screw so that it maintains the proper position within the radiation shield.

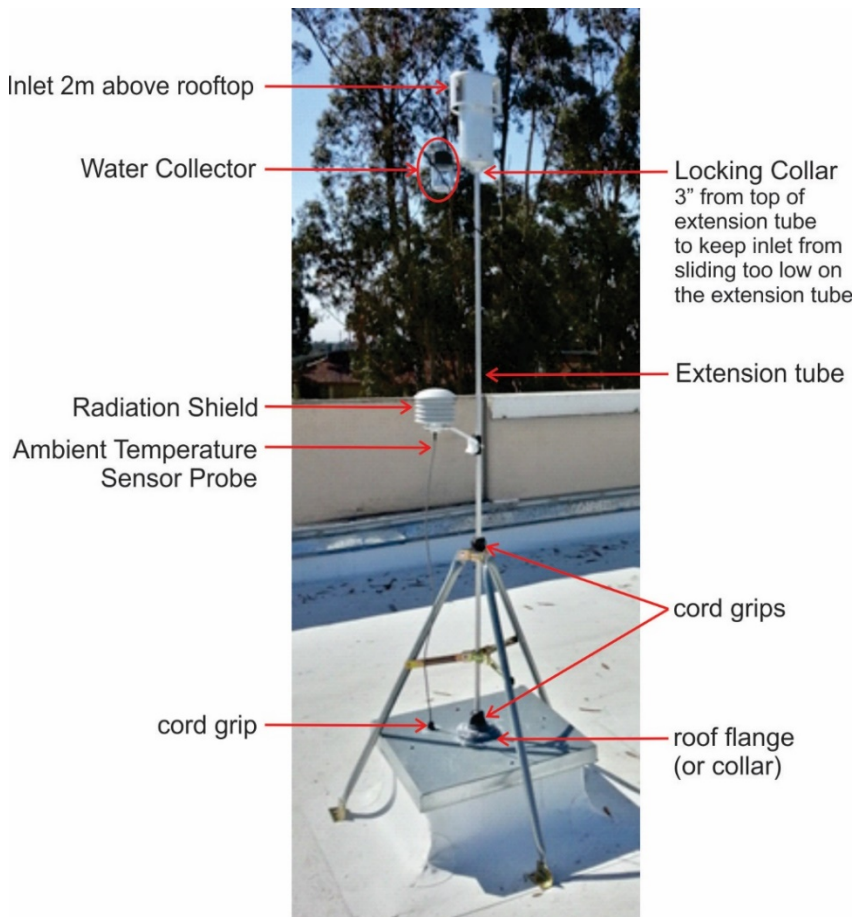

Figure 2-20. T640 Rooftop Sample Inlet and Extension Tubing Installation

15. Before sealing the cord grip, ensure the instrument is running properly:
 - a. With power cable, ASC, and ambient temperature sensor cables properly connected power up the instrument and wait until the LED temperature stabilizes (~10 minutes).
 - b. Perform Ambient Temperature Sensor verification (Section 4.1) first.
 - c. Following temperature sensor verification, perform Pressure verification (and calibration if necessary) (Section 4.2).
 - d. Following pressure sensor verification, perform Sample Flow verification (and calibration if necessary) (Section 4.3).
 - e. Next, for the 640x option, perform the Bypass Flow verification (and calibration if necessary) (Section 4.4); if no option, skip to next step.
 - f. Next, perform PMT verification with SpanDust™ and adjust as necessary (Section 4.5).
 - g. Last, perform the Leak Check (Section 4.6)
16. Once the T640 instrument is determined to be installed and working properly, tighten up the roof flange cord grip around the sample line.
17. Apply **clear silicone caulk** generously around the top end of where the cord grip rubber grommet meets the sample line to ensure complete sealing from the weather.
 - Silicone caulk seals well and can easily be removed and reapplied if the instrument needs to be removed for servicing.
18. Additionally, tighten up the tripod cord grip and lock down the feet of the tripod to fully secure the sample line.

2.4.2. OUTDOOR ENCLOSURE INSTALLATION

1. Place enclosure in the location where the instrument is to run.
2. The T640 instrument should be installed in the enclosure at a height where the inlet will be 2 m above ground (the base of the enclosure).
 - Make sure the optical sensor nozzle and nozzle to ASC adapter are installed on the optical sensor.
3. Once the T640 is in the enclosure and lined up with the cord grip opening on the top of the enclosure, insert the ASC into the cord grip (from above) and slide it down gently until it inserts into the ASC support of the T640.
 - The ASC should go into the T640 level and plumb, and is in completely when it is felt to bottom out onto the top of the optical sensor. This can be checked by lowering the front panel of the T640 and making sure the base of the ASC is touching the top of the optical sensor flush.

4. Plug the ASC connector into the proper fitting on the rear panel of the T640.
5. Connect the power cable and ambient temperature sensor at back of instrument.
6. Before sealing the cord grip, power up the instrument and make sure it is running properly
7. Perform Ambient Temperature, Ambient Pressure and Flow check/calibrations (Sections 4.1, 4.2, 4.3) – in that order).
8. Next, for the 640x option, perform the Bypass Flow verification (and calibration if necessary) (Section 4.4); if no option, skip to next step.
9. Perform PMT check with SpanDust™ (Section 4.5).
10. Last, perform the Leak Check (Section 4.6).
11. Once the T640 instrument is determined to be installed and working properly, tighten up the cord grip around the ASC.
12. Apply **clear silicone caulk** generously around the top end of where the cord grip rubber grommet meets the ASC to ensure complete sealing from the weather.
 - Silicone caulk seals well and can easily be removed and reapplied if the instrument needs to be removed for servicing.



T640:



640x:

Figure 2-21. T640 (left) and 640x (right) Outdoor Enclosures Assembled

2.5. PNEUMATICS

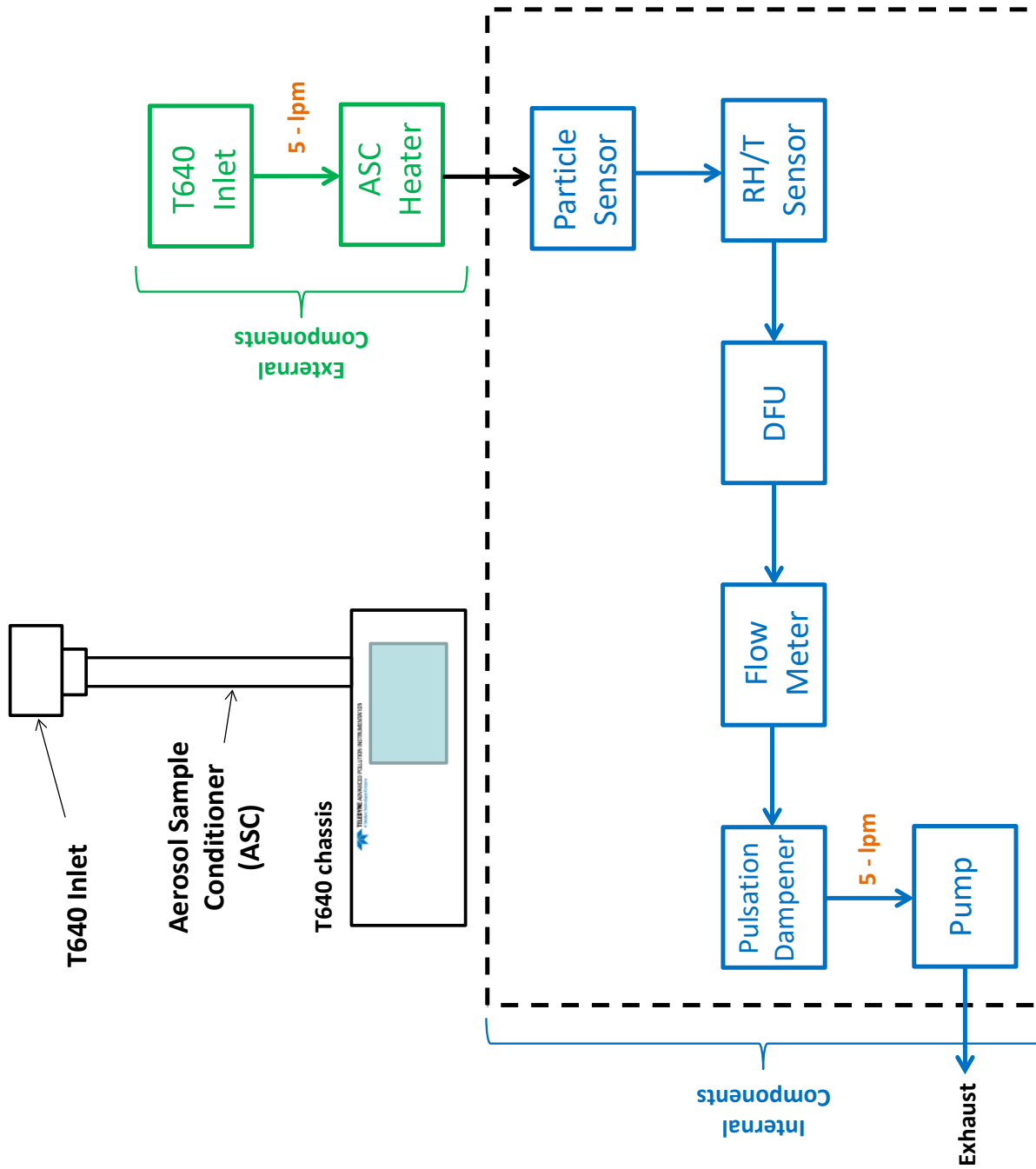

Figure 2-22. T640 Pneumatics

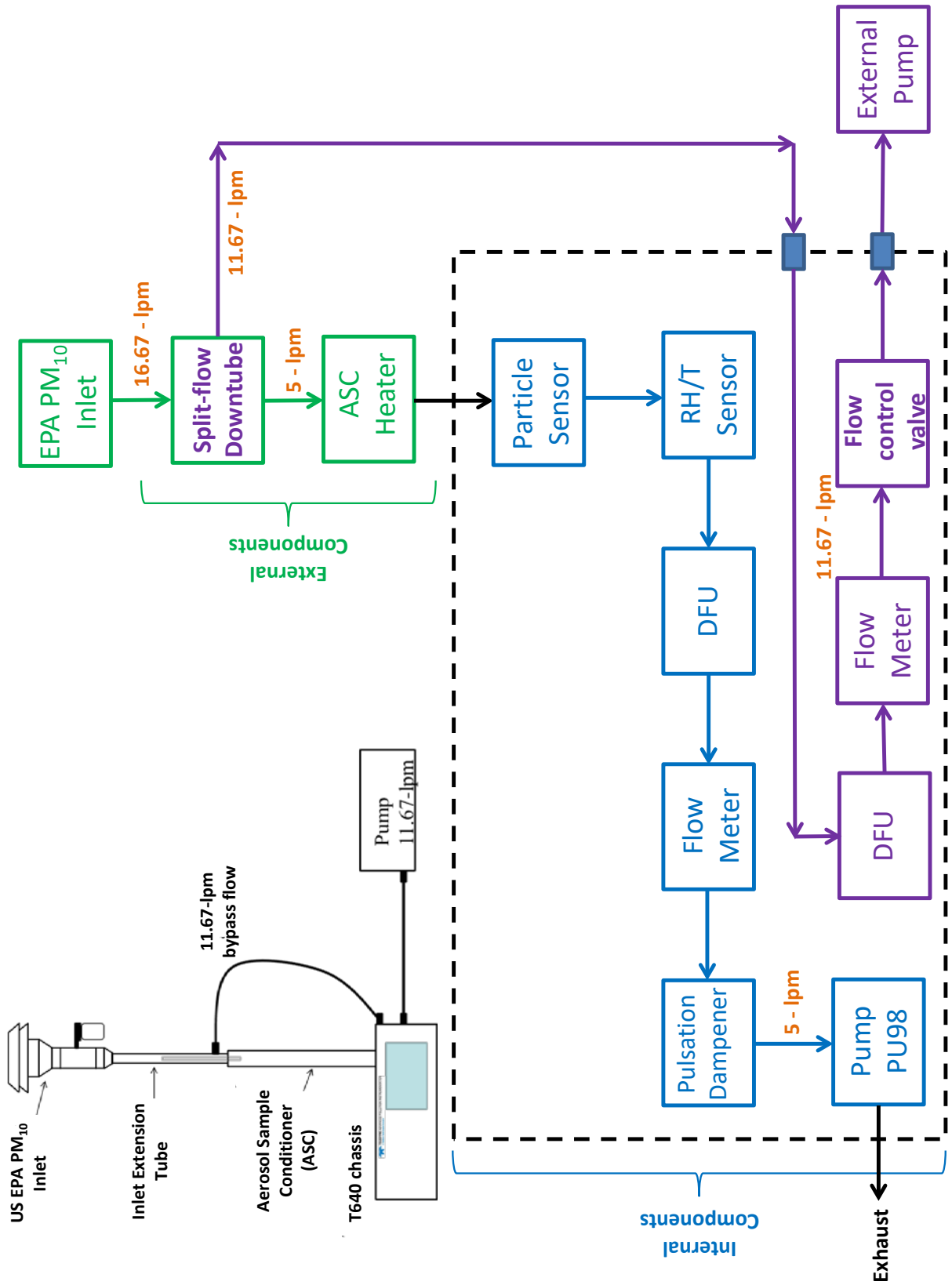

Figure 2-23. T640 with 640X Option Pneumatics

2.6. DISPLAY AND MENU NAVIGATION

The Home page shows the menu tabs in a column on the right and displays the gas name(s) and concentration reading(s) in the main portion of the screen; below that are meters displaying readings of three additional parameters (selectable in Home Configuration, Section 3.2.1). At the top of the interface are user tools and at the bottom are navigation buttons and indicators; Figure 2-24 presents a description of the NumaView™ software interface.

Details for using the menu system are presented in Section 3.

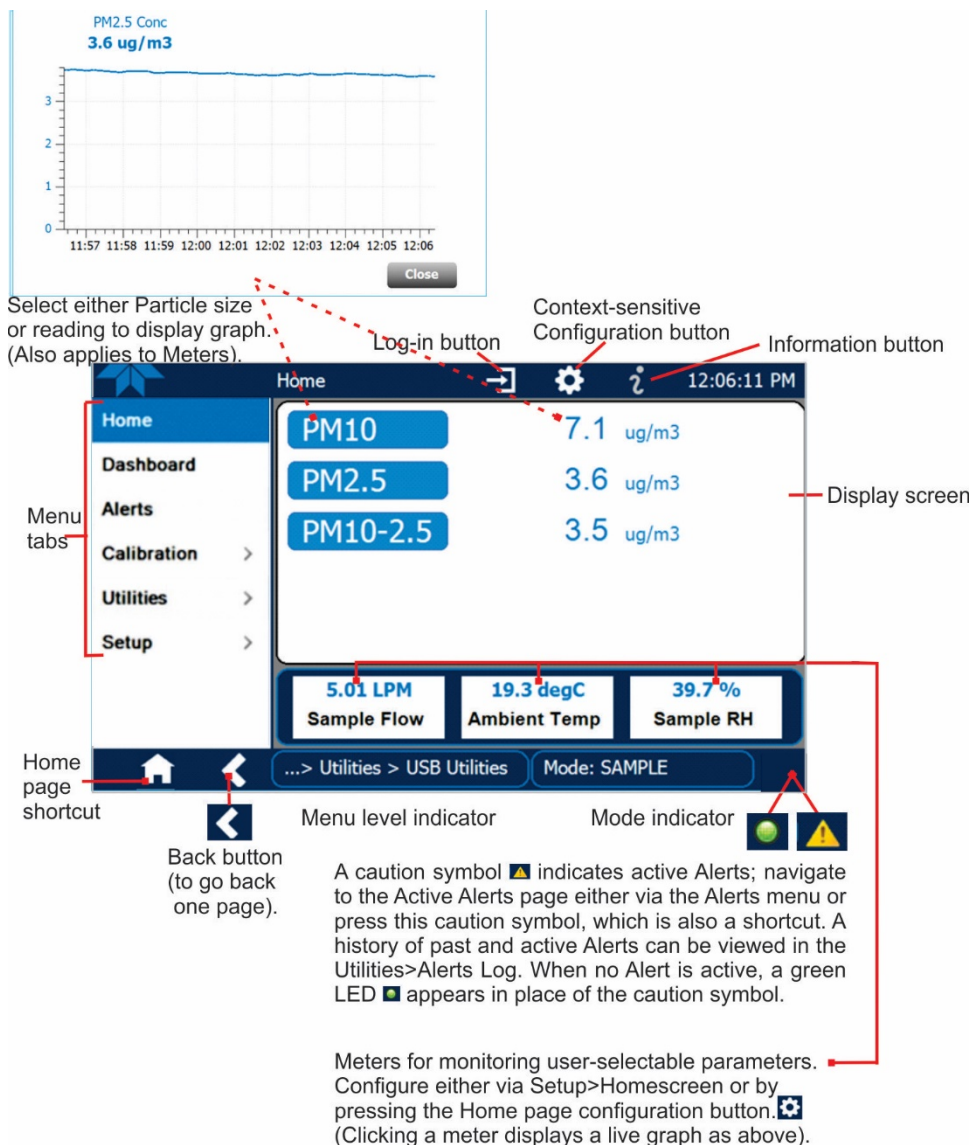

Figure 2-24. Sample Home Screen with Orientation

Figure 2-25 shows that pressing the gas name or its concentration value or a meter below displays a plot of the respective values. (Meters are selectable in HomeScreen, Section 3.2.1).

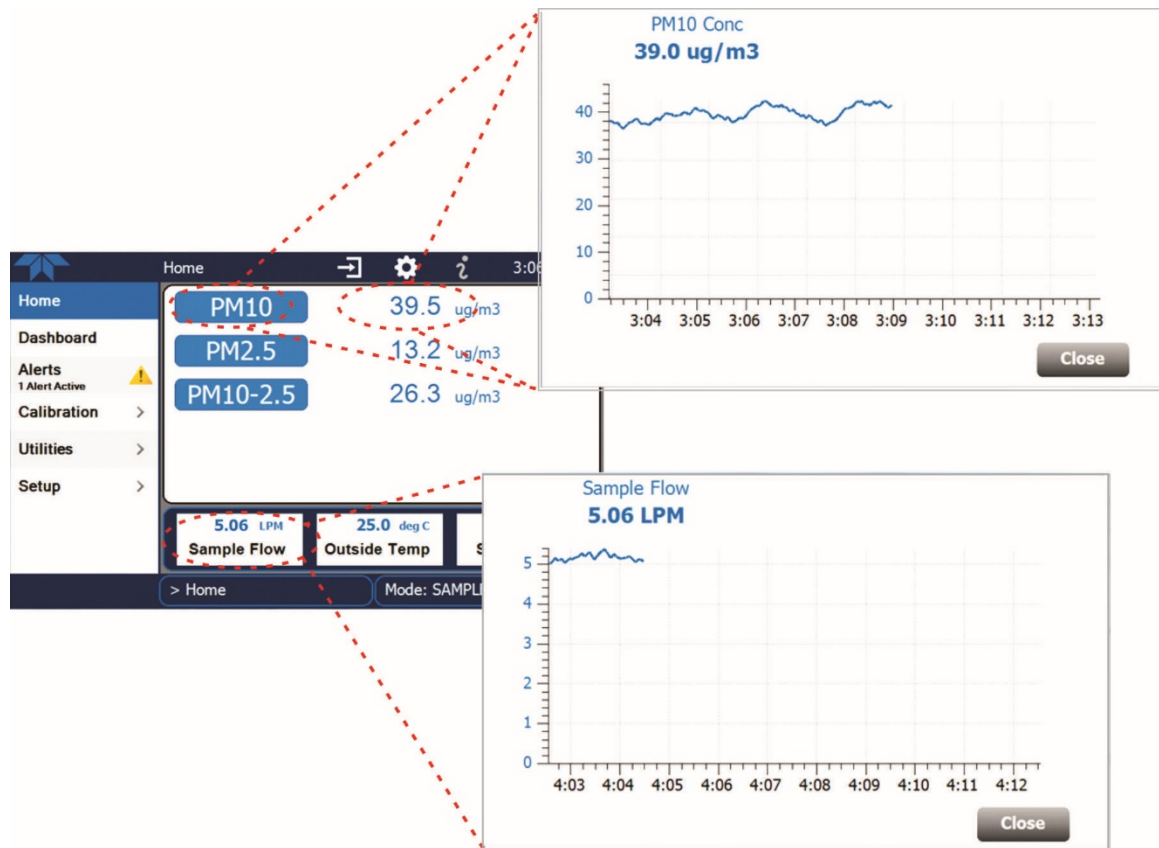

Figure 2-25. Concentration Graph and Meter Graph

2.7. STARTUP AND FUNCTIONAL CHECKS

2.7.1. STARTUP

Upon initial startup, allow the instrument to run for at least 10 minutes to reach stable operating conditions. Be sure the LED temperature has stabilized before valid measurements are obtained. No adjustments or calibrations should be performed until the LED temperature has stabilized.

2.7.2. FUNCTIONAL CHECKS OF OPERATING PARAMETERS

After warm-up, navigate to the Dashboard screen to verify that the Monitor is functioning within allowable operating parameters (the Appendix shows the list of test functions and their expected values; the enclosed *Final Test and Validation Data sheet* lists these values as they appeared before the instrument left the factory). If not all test functions and values are displayed here, touch the configuration icon to insert additional functions into the Dashboard (Section 3.2.2 has more details).

These functions can also be used as diagnostic tools for troubleshooting a performance problem.

2.7.2.1. INITIAL SENSOR CHECKS AND ADJUSTMENTS

Instructions for checking the ambient temperature sensor as well as checking and calibrating pressure and flow using customer-owned flow and pressure standards can be found in Sections 4.1, 4.3, 4.4, and 4.1.4.

IMPORTANT

IMPACT ON READINGS OR DATA

Avoid using NIST-reference devices that cause a pulsation (i.e. BIOS) as these will disrupt the T640 flow control feedback system. Devices that create a constant and small pressure drop are preferred.

Instructions for performing an optical sensor check and PMT adjustment are provided in Section 4.5.

3. SOFTWARE SETUP AND OPERATION

A high-level description of the menu system is presented in Section 3.1. Configuration and setup instructions are provided in Section 3.2, instructions for updating firmware in Section 3.3, and operation instructions in Section 3.3.

3.1. MENU SYSTEM OVERVIEW

MENU	DESCRIPTION	LOCATION
Home	View and plot concentration readings and other selectable parameter values (Figure 2-24).	Section 3.2.1
Dashboard	View user-selected parameters and their values, some of which can be displayed in a live-plot graph (Figure 3-2).	Section 3.2.2
Alerts	View and clear active Alerts that were triggered by factory-defined Events as well as user-defined Events. (Active and past Alerts are recorded in the Utilities>Alerts Log, Figure 3-3).	Section 3.2.3
Calibration	Run calibrations on sample flow, bypass flow, and pressure; test and adjust for drift, and check for leaks.	Section 4
Utilities	View logs, download data and firmware updates, copy configurations between instruments, and run diagnostics.	Sections 3.2.4, 3.2.5, 3.2.6

MENU	DESCRIPTION	LOCATION
Setup	Configure a variety of features and functions through these submenus for customized operation.	Section 3.2
Datalogging	Track and record concentration and calibration data and selectable diagnostic parameters, the reports for which can be viewed in the Utilities>Datalog View menu and downloaded to a flash drive via the Utilities>USB Utilities menu (Section Figure 3-15). Also, select configured Events (Section 3.2.8) and create customized triggers for data logging functions.	Section 3.2.7
Events	Select parameters and define the conditions by which they are to be flagged and recorded in the Alerts log (Section 3.2.5) when they are triggered. Once configured, Events can be used to trigger Datalogs (Section).	Section 3.2.8
Dashboard	Monitor instrument functionality (Figure 3-2) via selectable parameters.	Section 3.2.9
Vars	Manually adjust several software variables that define specific operational parameters.	Section 3.2.10
Homescreen	Configure the parameters to be displayed in the three meters (Figure 2-25).	Section 3.2.11
Instrument	View product and system information, including list of included options, if any; view network settings; view/adjust Date and Time settings*; and check for firmware updates when connected to a network that is connected to the Internet. *Time Zone change requires special procedures (Section 3.2.12.2).	Section 3.2.12
Comm	View and configure network and serial communications.	Section 3.2.13

3.2. CONFIGURATION AND SETUP

Configure pages, set up reporting parameters, and customize any of several features to suit user needs.

3.2.1. HOMESCREEN

Three meters at the bottom of Home page display user-selectable parameters and their values. To select, go to the Home Configuration page by touching the configuration button  (shortcut) and following the onscreen instructions (see Figure 3-1). The Home page can also be configured through the Setup menu (Section 3.2.11).

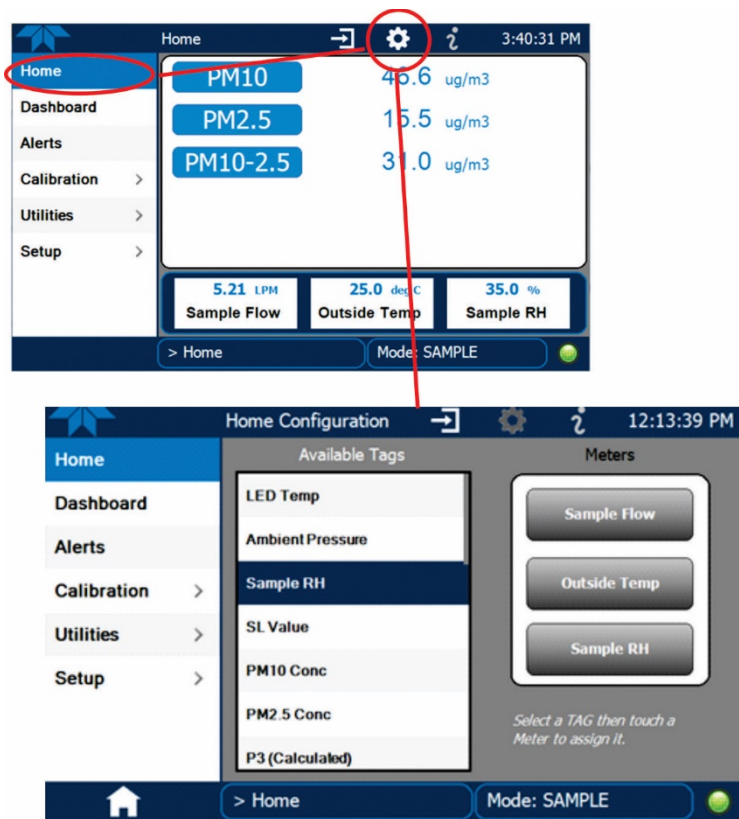

Figure 3-1. Home Configuration thru Home Page Shortcut

3.2.2. DASHBOARD

The Dashboard page (Figure 3-2) shows an array of user-selected parameters and their values. If there is a graphing icon in the upper right corner of a parameter, pressing that parameter displays a plot. (See Section 3.2.9 for configuration instructions).

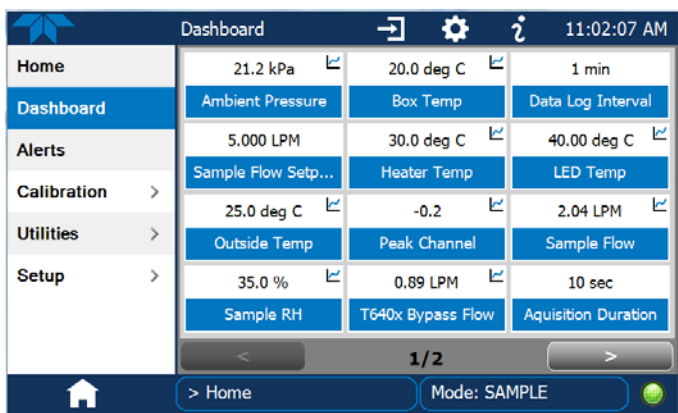

Figure 3-2. Dashboard

3.2.3. ALERTS

The Alerts screen shows the status of any active warning conditions or user-configured Events. (Events are used to define the conditions that will trigger Alerts; see Section 3.2.8 for detailed information and how to customize Events through the Home>Setup>Events menu). While Alerts can be cleared from the Alerts page, all alerts are documented and stored in the Home>Utilities>Alerts Log (Section 3.2.5).

3.2.4. UTILITIES>DATALOG VIEW

This utility provides reports on instrument data, the parameters for which are defined by the user in the data logger (Home>Setup>Data Logging). Section 3.2.7 provides instructions for configuring the data logger.

3.2.5. UTILITIES>ALERTS LOG

The Alerts Log (Figure 3-3) displays a history of Alerts (Section 3.2.3) that are triggered by factory-defined and user-defined Events (Section 3.2.8), such as warnings and alarms.

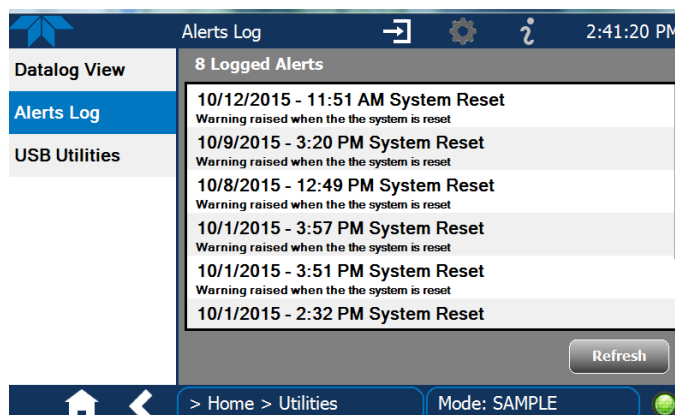

Figure 3-3. Alerts Log

3.2.6. UTILITIES>USB UTILITIES (DOWNLOADS AND UPDATES)

The USB Utility page serves multiple purposes using a flash drive connected to the instrument's front panel USB port:

- updating firmware (General tab)
- copying a configuration from one instrument to other same-model instruments (General tab)
- downloading Data Acquisition System (DAS) data from the instrument to a flash drive (DAS Download tab).
- downloading a basic operation functionality report (Report tab)

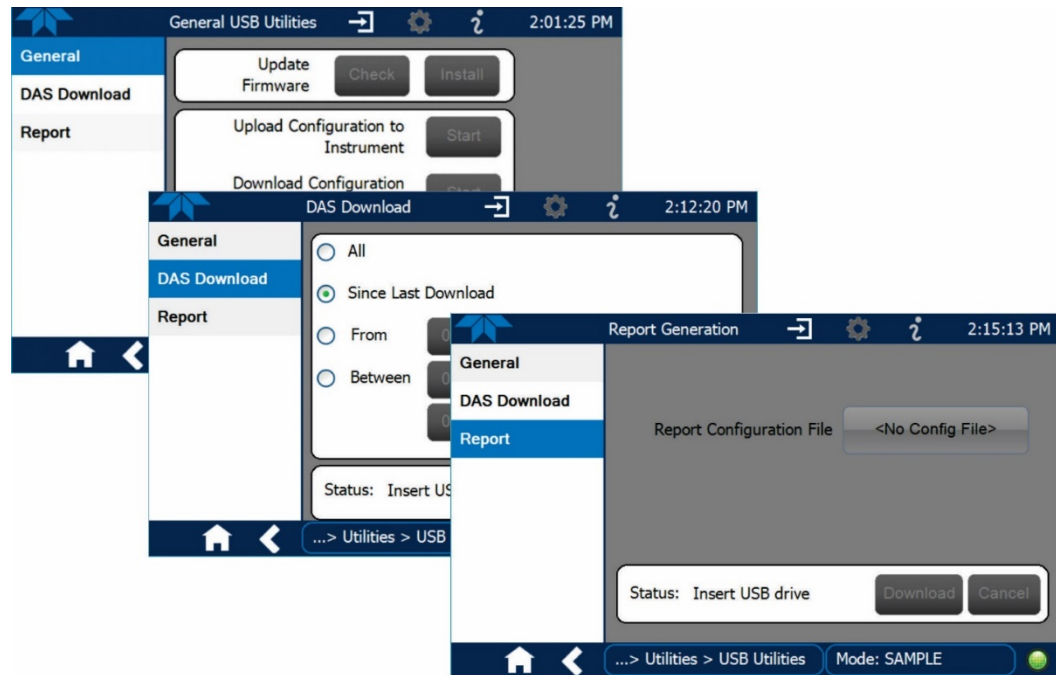

Figure 3-4. USB Utility Pages

The Status field shows when an inserted flash drive has been detected, at which time firmware updates, configuration copying and DAS downloading can be carried out.

3.2.6.1. DOWNLOADING DAS (DATA ACQUISITION SYSTEM) DATA

DAS data (collected by the Datalogger, Section 3.2.7) can be downloaded from the instrument to a flash drive through the Utilities>USB Utilities>DAS Download menu, as follows:

1. Insert a flash drive into a front panel USB port and wait for the Status field to indicate that the drive has been detected; available buttons will be enabled.

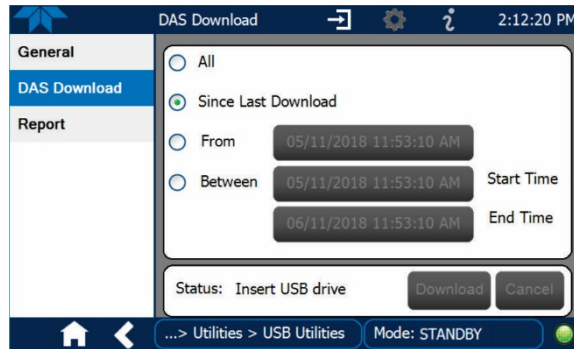

Figure 3-5: Das download Page

2. To copy the data to the flash drive, press the Start button next to “Download DAS Data from Instrument.” (The Cancel button will be enabled).
3. When complete, as indicated in the Status field, the Cancel button becomes the Done button: press Done and then remove the flash drive.

3.2.6.2. UPDATING SOFTWARE/FIRMWARE

If the system is connected to a network that is connected to the Internet, it can check for updates automatically or when the user prompts for a check. It is also possible to check for updates or reload current software/firmware manually. This section describes the various methods.

Automatic Update Notifications

When this feature is set to True (Setup>Vars>Periodically Check for Updates), the system will check every week for an update and trigger an Alert when an update is available, prompting the user to download the update

Manually Prompted Updates

The instrument must be connected to a network that is connected to the Internet. In the Setup>Instrument>Remote Update menu press the Check for Updates button. If the Status field shows that an update is available, it can be downloaded through this page.

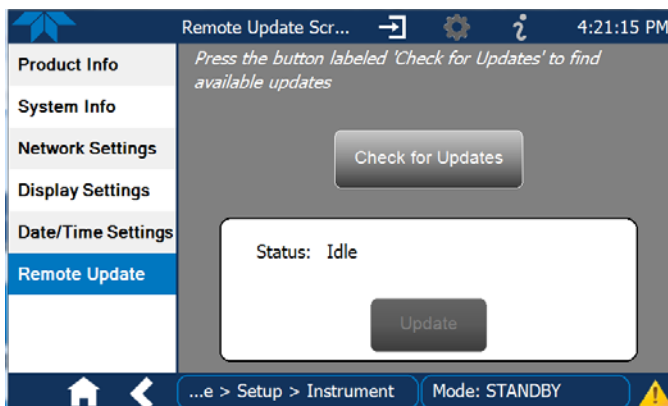

Figure 3-6: Remote Update Page

Manual Reload/Update Procedures

To reload or update firmware, first contact Technical Support to obtain the applicable file(s): sda_techsupport@teledyne.com / 800-324-5190.

1. Follow Technical Support's instructions for copying the firmware files to a flash drive.
2. Navigate to the Utilities>USB Utilities>General menu.

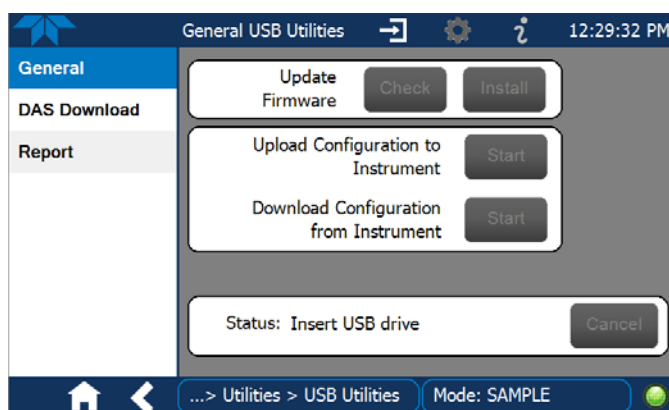

Figure 3-7: Manual Update Page (and other utilities)

3. Insert a flash drive into a front panel USB port and wait for the Status field to indicate that the drive has been detected.
4. In the Update Firmware field, press the Check button for the instrument to determine whether the firmware on the flash drive is more recent than what is currently installed. Once it's been determined that the firmware is new, the Install button will be enabled; if the firmware version on the

flash drive is the same as or older than the current firmware of the instrument, the Install button will not be enabled.

5. Press the Install button, and note the messages in the Status field at the bottom of the page. Use the Cancel button if necessary.
6. When complete, as indicated in the Status field, press the Done button, which replaces the Cancel button, and remove the flash drive.
7. Power off and restart the instrument to complete the new firmware installation.

3.2.6.3. TRANSFERRING CONFIGURATION TO OTHER INSTRUMENTS

Once an instrument is configured, the same configuration can be copied to other instruments of the same Model. This encompasses essentially anything the user can configure and does not apply to instrument-specific settings such as those that are configured at the factory for calibration.

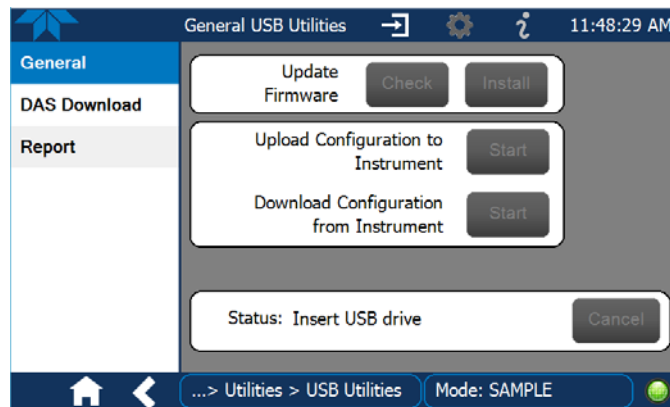

Figure 3-8: Configuration Transfer

1. In the source instrument, navigate to the Home>Utilities>USB Utilities>General page.
2. Insert a flash drive into either of the two front panel USB ports.
3. When the Status field indicates that the USB drive has been detected, press the “Download Configuration from Instrument” Start button.
4. When the Status field indicates that the download is complete, remove the flash drive.
5. In the target instrument, navigate to the Home>Utilities>USB Utilities>General page.
6. Insert a flash drive into either of the two front panel USB ports.
7. When the Status field indicates that the USB drive has been detected, press the “Upload Configuration to Instrument” Start button.

When the Status field indicates that the upload is complete, remove the flash drive.

3.2.6.4. GENERATING A REPORT

The Report page is used typically for monitoring the functionality of the instrument. When the Var for this feature is set to True (Setup>Vars>Upload Report to Cloud), the report is generated every 24 hours to the Internet (the “cloud”) where it is available for viewing by Teledyne API technical support personnel. To download the report for your own viewing on a computer or to send to others, insert a flash drive into a front panel USB port and press the Download button, which is enabled when the instrument detects the flash drive.

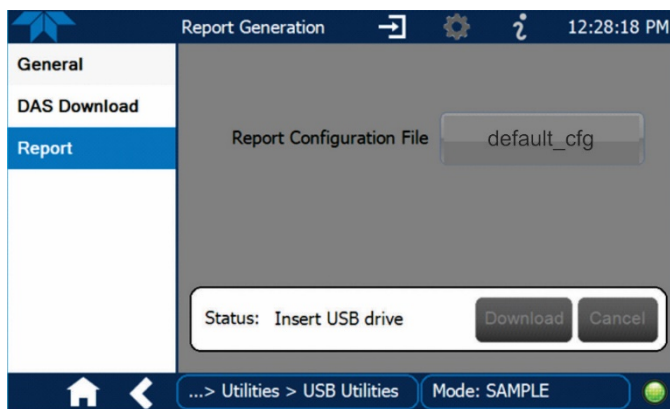

Figure 3-9: Report Generation Page

3.2.7. SETUP>DATA LOGGING

The Data Logger captures and stores user-defined data, which then can be downloaded from the instrument to a USB flash drive for examination and analysis. Press the ADD button to create a new log (Figure 3-10), or select an existing log from the Data Logging list and press the EDIT or DELETE button to make the desired changes (Figure 3-11). See Sections 3.2.7.1 and 3.2.7.2 for configuration details, and Section 3.2.7.3 for transferring captured instrument data to a flash drive.

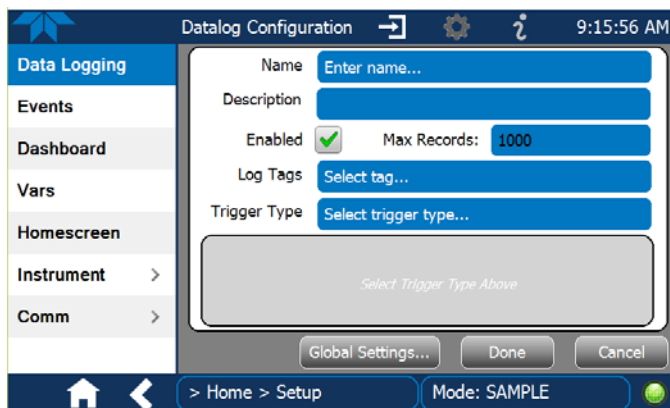

Figure 3-10. Datalog Configuration, New Log Page

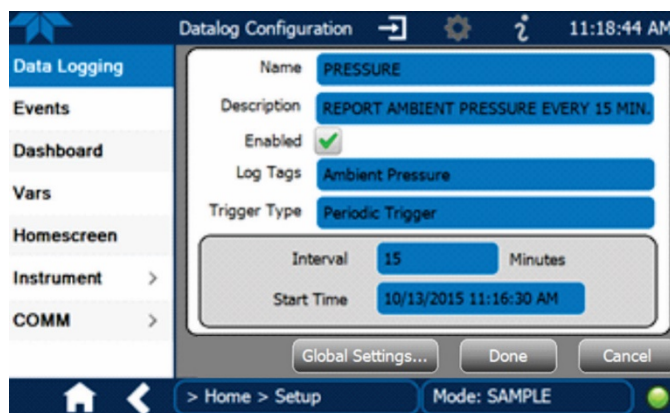

Figure 3-11. Datalog Configuration, Existing Log

3.2.7.1. CREATING A USER-DEFINED DATA LOG

Press the Name field and use the keyboard pop-up to label the new log.

Press the Description field and use the keyboard pop-up to describe the log.

Leave the Enabled box checked to allow data capture of this log, or press to uncheck and suspend data capture.

Press the Log Tag field to select one or more parameters for the new data log.

Press the Trigger Type field to select either Periodic or Conditional.

Select between 12-hr and 24-hr time format and whether to include UTC in datalog.

When **Periodic** is selected as the Trigger Type, the field below it is populated with the Interval/Date/Time window.

When **Conditional** is selected as the Trigger Type, the field below it is populated with the Trigger and Condition definition window.

(Please refer to the section on Configuring Trigger Types for details).

Figure 3-12. Creating a New Data Log

3.2.7.2. CONFIGURING TRIGGER TYPES

Two trigger types can be configured: periodic and conditional.

Periodic Trigger

The Periodic trigger is a timer-based trigger that is used to log data at a specific time interval. Periodic Trigger requires an interval that is set to number of minutes and a start time that is set to date and time.

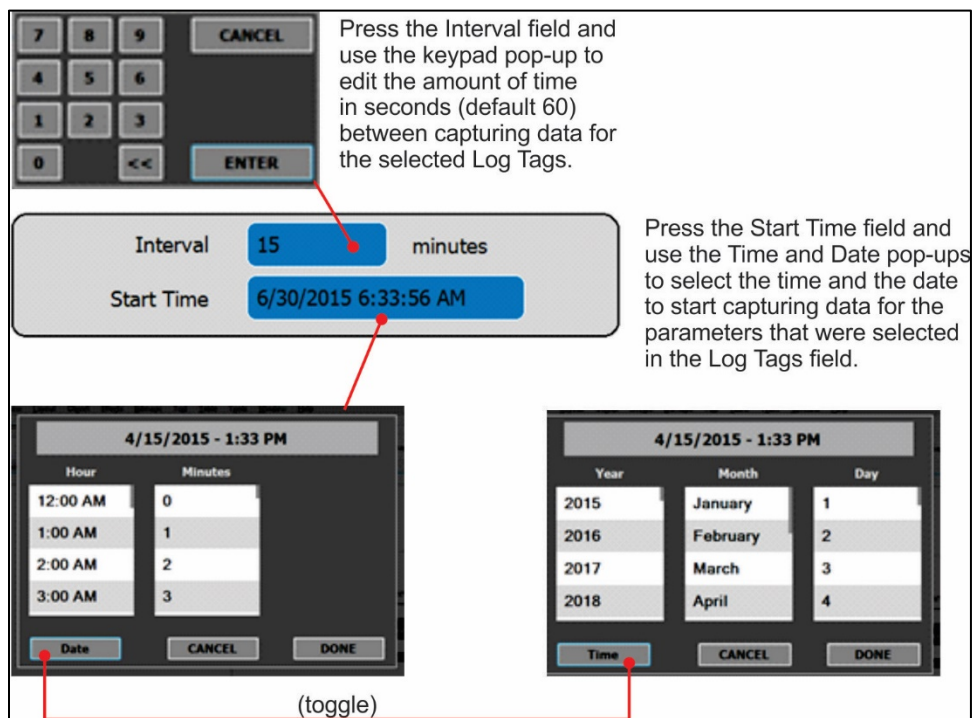

Figure 3-13. Datalog Periodic Trigger Configuration

Conditional Trigger

Conditional Trigger tracks/records data for user-selected parameters that meet specified conditions.

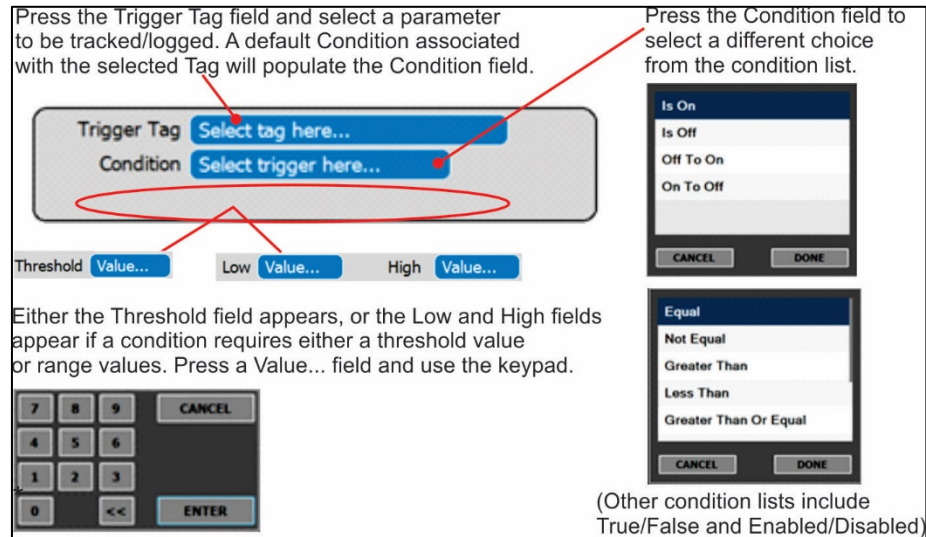

Figure 3-14. Datalog - Conditional Trigger Configuration

3.2.7.3. DOWNLOADING DAS (DATA ACQUISITION SYSTEM) DATA

In the Utilities>USB Utilities menu instrument data can be downloaded to a flash drive, as presented here.

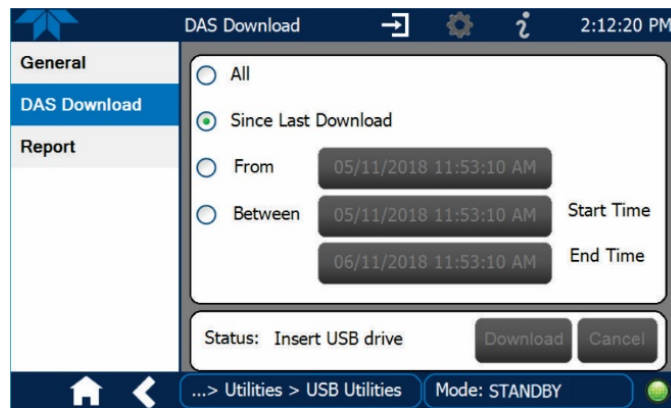

Figure 3-15. DAS Data Utility

1. In the Utilities>USB Utilities>DAS Download menu, choose the time period to be downloaded:
 - All DAS data captured
 - Only the data since last download operation
 - Only the data from a past date and time to the present
 - Only the data captured between specified dates and times

2. Insert a flash drive into a front panel USB port and wait for the buttons in the Status field to become active: press Download to begin or Cancel to abort.
3. Wait for the Status field to indicate that the transfer is complete and remove the flash drive.

3.2.8. SETUP>EVENTS

Events are occurrences that relate to any operating function, and are used to define the conditions that will trigger Alerts (Sections 3.2.3 and 3.2.5). Events can provide diagnostic information about the instrument, typically referred to as “Warnings”, or they can provide additional instrument functionality, such as concentration alarms.

The instrument comes from the factory with a number of pre-defined warning Events, and the Events Configuration page provides the capability for creating additional, user-defined events (Section 3.2.8.1) and editing them (Section 3.2.8.2).

To view a list of Warnings and Event tags, press the Add button, and highlight a tag to view its description.

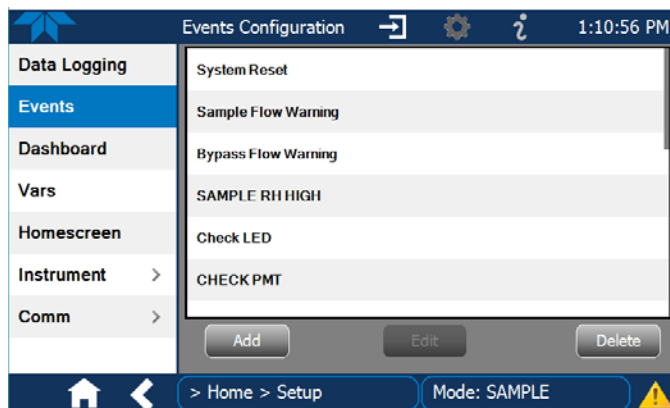

Figure 3-16. Events Page

3.2.8.1. CREATING USER-DEFINED EVENTS

In the Home>Setup>Events menu (Figure 3-16) press ADD to create a new Event. Figure 3-17 depicts what to do next. Check the **Enabled** box to track and record the Event. Check the **Visible** box to display the Event in the Alerts tab when it is triggered (the Event will be recorded whether. Check the **Latching** box to make it a Latching Event. To see a description of any tag, touch its name in the list that pops up after touching the Trigger Tag field.

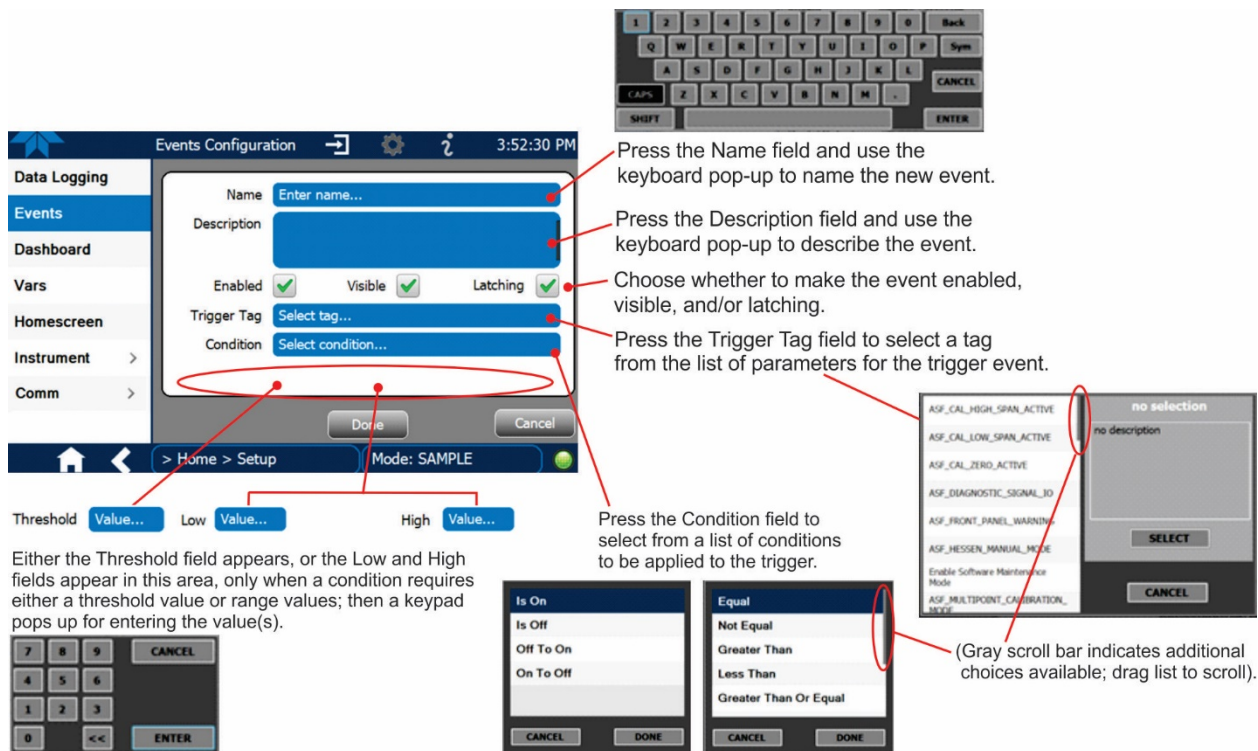

Figure 3-17. Event Configuration

3.2.8.2. EDITING OR DELETING EVENTS

Select an Event from the list in the Events page (Figure 3-16) and press the EDIT button to view or edit the details (Figure 3-18). To delete an Event, select the Event from the list in the Events page and press the DELETE button.

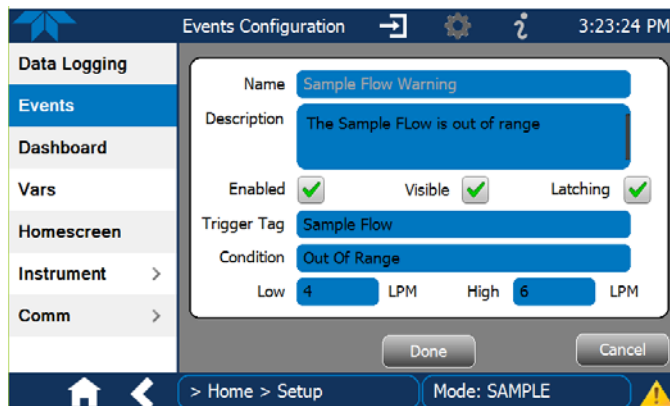



Figure 3-18. Existing Event for Viewing or Editing

3.2.9. SETUP>DASHBOARD

Configure this page either while in the Home>Dashboard page by touching the configuration button  (shortcut) or through the Home>Setup>Dashboard menu (Figure 3-19). Also see Section 3.2.2 for a description of this page.

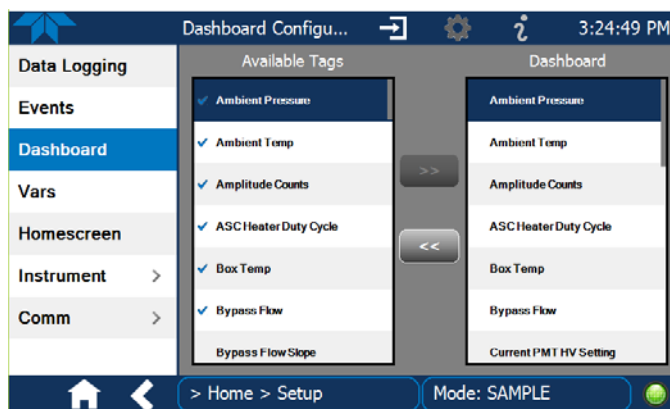

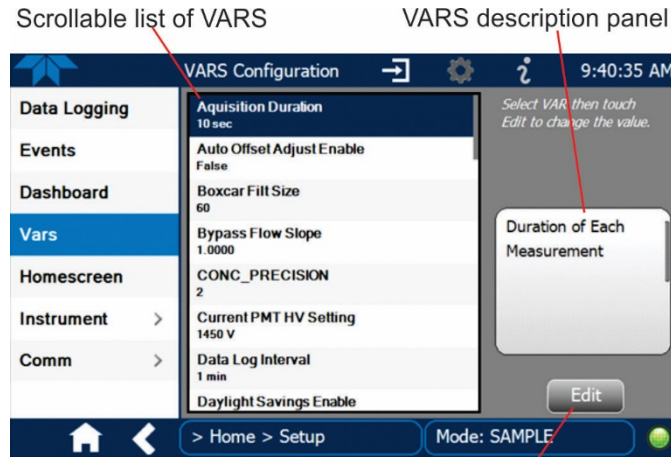

Figure 3-19. Dashboard Configuration

- To add a parameter for display in the Dashboard, make a selection from the “Available Tags” column and press the right-pointing button .
- To remove a parameter from the Dashboard, select a tag from the “Dashboard” column and press the left-pointing button .

3.2.10. SETUP>VARS (VARIABLES)

The VARS configuration page allows selecting a Variable and pressing the Edit button to change its values or conditions. This page provides a description of each variable as it is selected/highlighted.



Select a variable from the list and touch the Edit button.

Figure 3-20. VARS Configuration Page

3.2.11. SETUP>HOMESCREEN

Select parameters for the three meters at the bottom of Home page from the Home>Setup>Homescreen menu (Figure 3-21. Home Configuration thru Setup Menu) and follow the onscreen instructions. The Home Configuration page can also be accessed by shortcut (⚙️) in Home (see Section 3.2.1).



Figure 3-21. Home Configuration thru Setup Menu

3.2.12. SETUP>INSTRUMENT

As presented in Table 3-1, view product and system information and network settings, edit network settings, and perform certain maintenance tasks.

Table 3-1. Setup>Instrument Menu

MENU	DESCRIPTION
Product Info	View Model, Part, and Serial Numbers and Package and Driver Versions, and options information.
System Info	View Windows, RAM, and disk size/space information.
Network Settings	View the network settings (configurable through the Setup>Comm>Network Settings menu, Section 3.2.13).
Date/Time Settings	Adjust date, hour, and minutes, select a time zone*, and set the system clock to either automatically adjust for Daylight Savings Time or not. (Also see Setup>Vars>Daylight Savings Enable). *Time Zone change requires a special procedure (Section 3.2.12.2).
NTP Time Settings	Configure Network Time Protocol settings for clock adjustments to synchronize time.
Language	Select an available language.
Remote Update	When an instrument is connected to a network that is connected to the Internet, follow the instructions on this Remote Update page to check for and activate software/firmware updates. (Also see Section 3.2.6.2).

3.2.12.1. INSTRUMENT DISPLAY CALIBRATION (FOR EARLIER INSTRUMENTS)

This section applies to instruments shipped before January 2017. Although unlikely, if ever the touchscreen appears unresponsive or responds incorrectly, the screen can be calibrated via the Setup>Instrument>Display Settings menu.

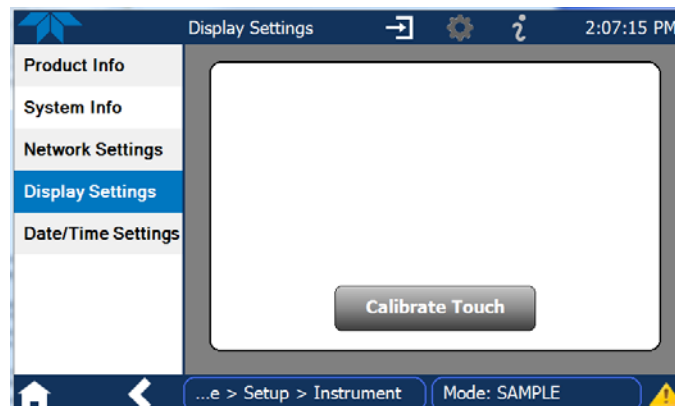

Figure 3-22. Touchscreen Calibration Page

1. Connect a mouse to either of the front panel USB ports.
2. Navigate with the pointer to Setup>Instrument>Display Settings.

3. Click on “Calibrate Touch” and a crosshair appears in the center of the display screen.

Note

A timer function is enabled, allowing only 15 seconds to start the calibration process. If the timer expires, the instrument will exit the calibration screen and return to normal operation.

4. Click the very center of the crosshair.
5. When a new crosshair appears in the upper left corner of the screen, carefully and accurately click and hold the very center of that crosshair until it finishes shrinking, then release.
6. Repeat Step 5 for each of the corners.
7. Once the process is completed, a CANCEL and an ACCEPT button appear in the lower left corner: Test the accuracy of the calibration by touching parts of the screen and see that the mouse pointer follows your touches.
8. If you press the CANCEL button, the calibration won't be altered. Otherwise, press the ACCEPT button.

If any difficulties with the display screen persist, contact TAPI Technical Support:

sda_techsupport@teledyne.com / 800-324-5190

3.2.12.2. INSTRUMENT DATE/TIME ADJUSTMENTS

The Date/Time Settings menu allows changes to time zone, hour, minutes after the hour, and date, including auto-adjust for Daylight Savings Time.

If the Time Zone requires change, it must be set first, and the instrument must be restarted before making any other changes, including date or time, to ensure changes are not lost.

IMPORTANT

IMPACT ON TIME ZONE

If the instrument is restarted without allowing adequate time for a Time Zone change to be accepted, the change will be lost. Verify the change by returning to Home page, then navigating back to the Date/Time Settings; if the selected Time Zone is highlighted, then the change is set for taking effect after the instrument is restarted.

Changes to date and/or time do not require a reboot.

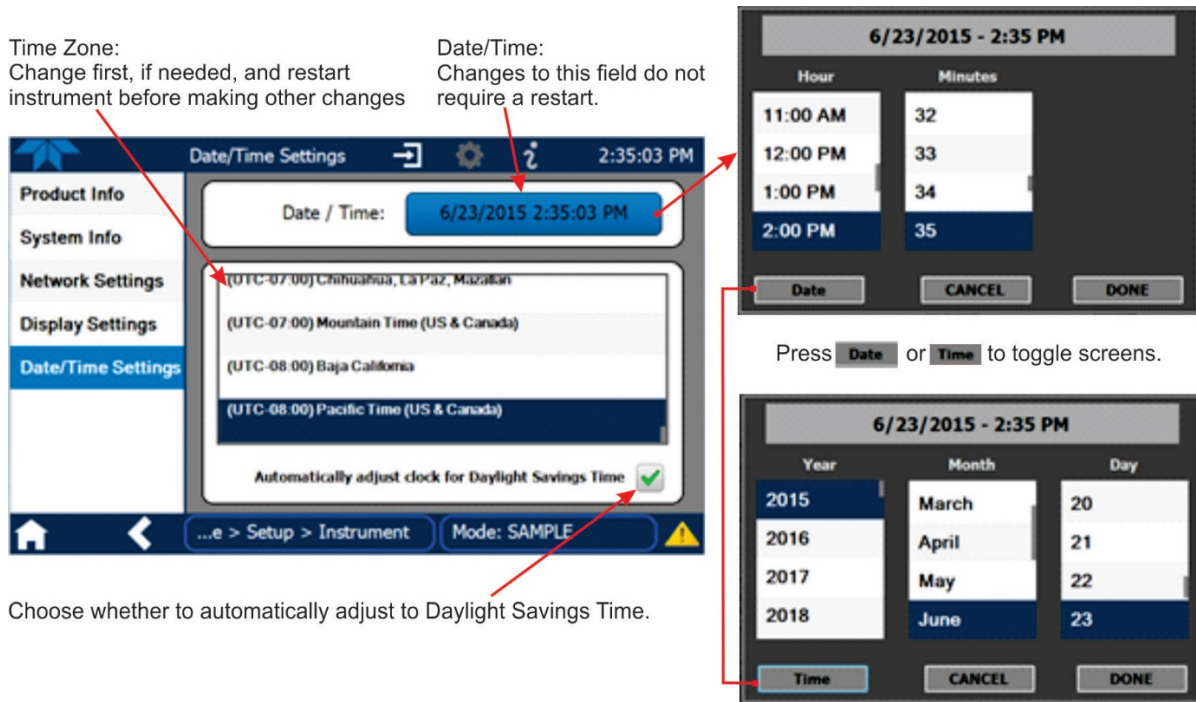

Figure 3-23. Date and Time Configuration Page

3.2.13. SETUP>COMM (COMMUNICATIONS SETUP)

The Setup>COMM menu is for configuring the communications port. (The last page on display prior to going to the Setup>COMM menu remains on display until one of the submenus is selected). TCP Port1 is for communication via a terminal emulation program; TCP Port2 is for communication via MODBUS protocol, and Network Settings is for communications via Ethernet.

3.2.13.1. TCP PORT1

TCP Port1 allows choosing whether or not to display the command prompt, editing the Port 1 number for defining the terminal control port by which terminal emulation software addresses the instrument, and enabling or disabling security on this port.

3.2.13.2. TCP PORT2

TCP Port2 is configured with the port number for MODBUS. The MODBUS Register is presented in Table 3-2.

Table 3-2. T640 MODBUS Register

MODBUS REGISTER ADDRESS (DECIMAL, 0-BASED)	DESCRIPTION
DISCRETE INPUTS REGISTERS (SINGLE-BIT; READ-ONLY)	
0	Box Temp Warning
1	Flow Alarm
2	System Fault Warning
3	System is OK
4	System Reset Warning
5	Temperature Alarm
6	System Service Warning
7	OPC Instrument Warning
8	Sample Temperature Warning
INPUT REGISTERS (READ-ONLY)	
(32-bit Integer)	
0	Pump Tachometer Reading
2	Number of total particles in the Amplitude histogram
4	Total number of particles in the Length distribution
(32-bit IEEE 754 format; read in high-word, low-word order)	
6	Real-time PM10 concentration value
8	Real-time PM2.5 concentration value

MODBUS REGISTER ADDRESS (DECIMAL, 0-BASED)	DESCRIPTION
10	Real-time PM10-2.5 concentration derived by subtracting the PM2.5 value from PM10
12	Real-time PM10 standardized concentration value
14	PM10 1Hr rolling concentration average
16	PM2.5 1Hr rolling concentration average
18	PM10-2.5 1Hr rolling concentration average
20	PM10 12Hr rolling concentration average
22	PM2.5 12Hr rolling concentration average
24	PM10-2.5 12Hr rolling concentration average
26	PM10 24Hr rolling concentration average
28	PM2.5 24Hr rolling concentration average
30	PM10-2.5 24Hr rolling concentration average
32	LED Temperature
34	Ambient Pressure
36	Humidity Sensor Reading
38	Box Temperature
40	Ambient Temperature Probe Reading
42	Temperature in the ASC Tube Jacket
44	Sample Stream Temperature at RH Sensor
46	Sample Flow5
48	640x Option Bypass Flow 11.67LPM
50	Sample Flow + Bypass Flow
52	Signal Length Max Value
54	P3 Value for Signal Length Histogram
56	Pump Duty Cycle / Pump PWM Status - Flag at 80%
58	Proportional Valve Duty Cycle / Valve PWM Status - Flag at 85%
60	ASC Heater Duty Cycle

HOLDING REGISTERS (READ/WRITE)

(32-bit Integer)

0	PMT voltage setting - DAC counts
2	Value returned by the send Offset Adjust function
4	PMT HVPS setting determined during cal dust calibration

(32-bit IEEE 754 format; read/write in high-word, low-word order)

6	5-LPM Flowmeter Calibration Slope
8	640x Bypass Flowmeter Calibration Slope
10	Pressure Sensor Calibration Slope
12	Setpoint for the sample RH
14	Flow Setpoint for the optical sensor
16	Setpoint for the 640x Option bypass flow
18	RH sensor slope

3.2.13.3. NETWORK SETTINGS

The Network Settings menu is for Ethernet configuration. The address settings default to automatic configuration by Dynamic Host Configuration Protocol (DHCP). Most users will want to configure the instrument with a static IP address; click the Static radio button to manually assign a static IP address (consult your network administrator, and see Table 3-3 for information).

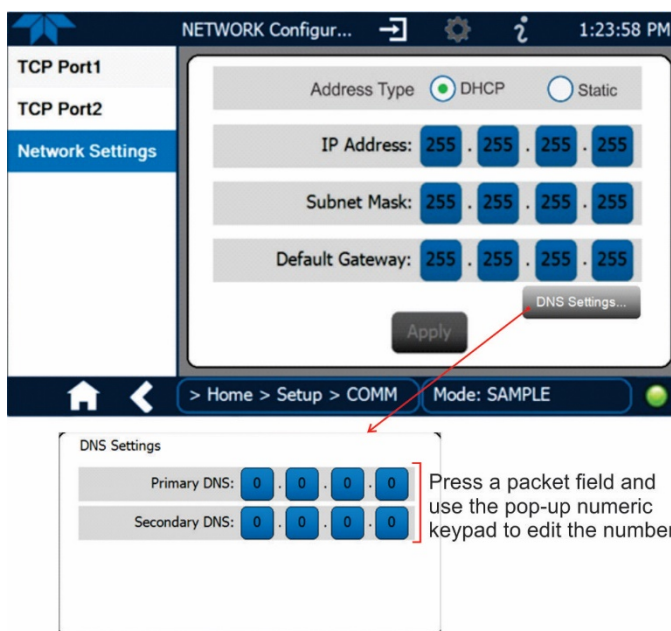

Figure 3-24. Communications Configuration, Network Settings

Table 3-3. LAN/Ethernet Configuration Properties

PROPERTY		DESCRIPTION
IP Address	0.0.0.0	This string of four packets of 1 to 3 numbers each (e.g. 192.168.76.55.) is the address of the instrument itself.
Subnet Mask	0.0.0.0	A string of four packets of 1 to 3 numbers each (e.g. 255.255.252.0) that identifies the LAN to which the device is connected. All addressable devices and computers on a LAN must have the same subnet mask. Any transmissions sent to devices with different subnets are assumed to be outside of the LAN and are routed through the gateway computer onto the Internet.
Default Gateway	0.0.0.0	A string of numbers very similar to the Instrument IP address (e.g. 192.168.76.1.) that is the address of the computer used by your LAN to access the Internet.

3.3. OPERATION

Upon startup, sampling will be calculated and displayed after a warming period during which time the LED temperature stabilizes for reliable readings.

4. SENSOR CHECKS AND ADJUSTMENTS

The following equipment, supplies, and expendables are required for sensor checks and adjustments:

- for ambient temperature, ambient pressure and flow(s): auditing device (NIST-traceable pressure, temperature, and flow standard with actual volumetric conversion)
- for PMT Adjustment: SpanDust™ bottle (provided with instrument)
- for Leak Test: Leak Check / Adapter Kit (TAPI PN 084910000)

IMPORTANT

IMPACT ON READINGS OR DATA

Calibrate Pressure prior to calibrating Sample or Bypass Flow

There are four basic checks and adjustments that should always be performed in a specific order as shown below:

- Ambient temperature sensor check
- Ambient pressure sensor check (and calibration, if needed).
- Sample and Bypass flow sensor check(s) (and calibration, if needed).
- PMT verification using SpanDust™ (and adjustment, if needed).
- Leak Test

All of these functions are performed in the Calibration menu of the instrument software.

See maintenance schedule in Section 5.1 for recommended intervals for these procedures.

For the Pressure and Flow Calibration menus, note that the “Measured” parameter provides the value measured by the instrument, and the “Actual” parameter is the value that is to be input from the reading measured by the external auditing device.

The T640 has been provided with a “short temperature probe” for the purposes of operating flow calibrations as well as PMT checks inside indoor shelters. The purpose of this is for the ambient temperature measurement to match the flow device at the location of the flow standard. In the case of the PMT adjustment, it is so the volumetric flow is relative to the indoor air temperature.

Additionally, the T640 has an optional “Leak Check, Flow Audit Adaptor Kit”. This kit includes fittings for adapting your flow audit device to the sample tube for either the T640 or 640x option, and also contains a filter for running a “leak check”. A picture of the kit contents are shown below:



Figure 4-1. Leak-Check/Flow-Audit Adaptor Kit

4.1. AMBIENT TEMPERATURE SENSOR CHECK

The reading for the ambient temperature sensor can be found in the Dashboard (if not, configure per Section 3.2.9).

Set the temperature reference standard next to the ambient temperature sensor and wait until the temperature readings for both stabilize. While the temperature sensor cannot be calibrated, it should be checked to make sure it is within $\pm 2^{\circ}\text{C}$ of a reference standard.

The temperature reading is used for volumetric flow, and once the flow has been calibrated, it is the change in temperature that really matters (rather than the temperature itself). So if the sensor does not read exactly the same as a reference standard, that is not as important as whether their ΔT match (i.e. change in temperature over the same period of time).

4.2. PRESSURE SENSOR CHECK AND CALIBRATION

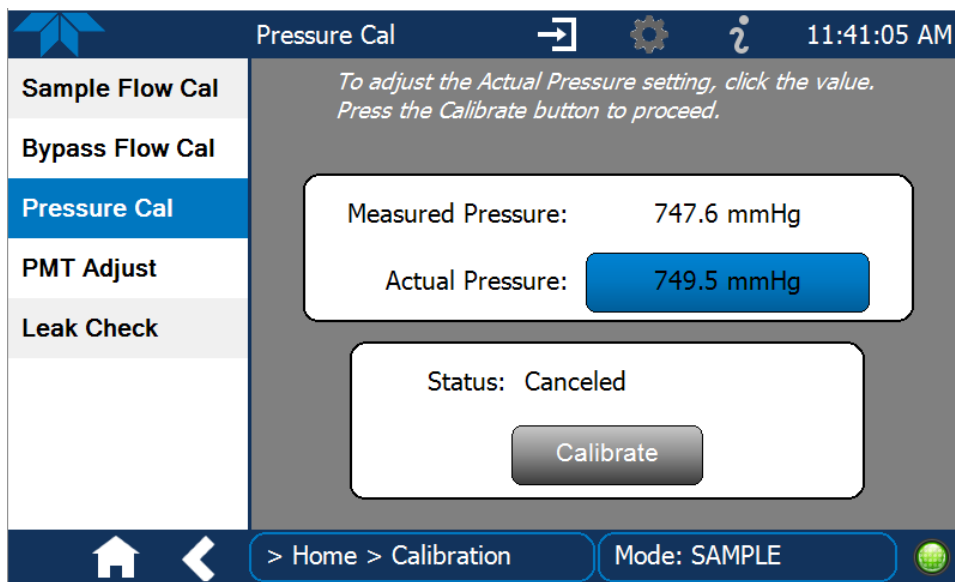

Figure 4-2. Pressure Cal Menu

IMPORTANT

IMPACT ON READINGS OR DATA

Perform this check/calibration *prior* to any flow calibration.

The T640 ambient pressure sensor is located within the instrument chassis. No direct pneumatic connection to the instrument needs to be made to perform this check/calibration. The units of measure can be displayed in either kPa or mmHg. This setting exists in the VARS menu.

1. With the NIST-traceable pressure standard reference device operating and measuring the ambient pressure in the same room as the T640, navigate to the Pressure Cal menu (Calibration>Pressure Cal).
2. Compare the “Measured Pressure” in this screen to the Pressure Standard.
3. If the two values differ by ± 10 mmHg, then press the value button in the “Actual Pressure” field, enter the value measured by the Pressure Standard into the keypad pop up, and then press the “Calibrate” button on this screen. Following the prompt, confirm the instruments pressure sensor measurement matches the NIST-traceable pressure standard reference device closely and the procedure is complete.

4.3. SAMPLE FLOW CAL (5-LPM)

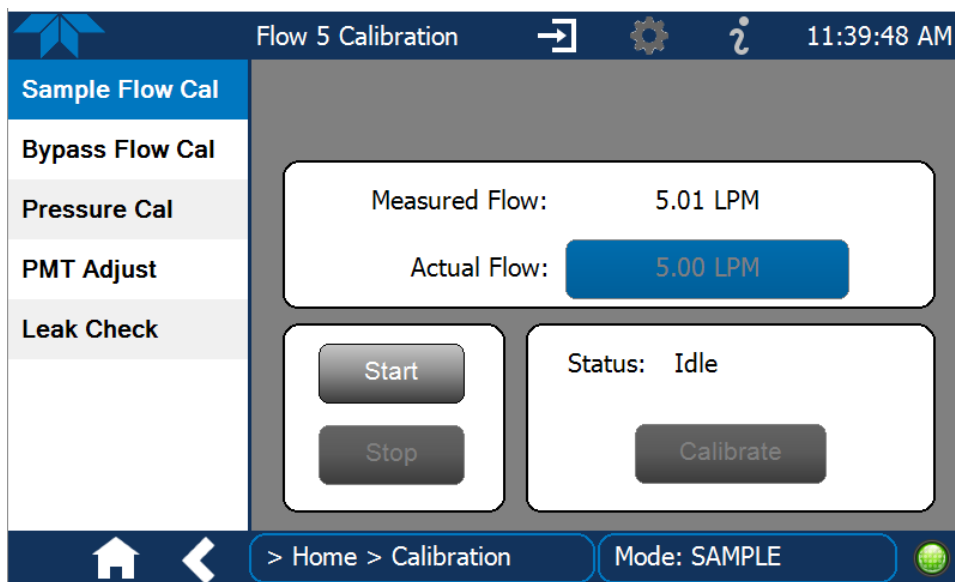

Figure 4-3. Sample Flow Cal Menu

IMPORTANT

IMPACT ON READINGS OR DATA

Perform Pressure Cal first (Section 4.1).

Also, avoid using NIST-reference devices that cause a pulsation (i.e. BIOS) as these will disrupt the T640 flow control feedback system. Devices that create a constant and small pressure drop are preferred.

1. If running in an “indoor installation”, decouple the ASC from the sample tube using the slip coupler.
 - Slide the slip coupler up, and move the instrument over to disconnect from the ambient sampling line
 - Plug in the “short ambient temperature probe” at the rear of the instrument in place of the normal ambient temperature probe
 - This is so that the T640 and the flow standard are measuring the same temperature during the calibration process.
2. If running in an “indoor installation”, but verifying flow from the roof-top, or if running from an outdoor enclosure where the flow standard is being used outside:
 - Keep the ambient temperature probe installed
 - Remove the inlet from the Upper Inlet Tube and follow the calibration procedure
3. Setup your NIST-traceable flow transfer standard device with the appropriate inlet for the flow to be calibrated.

4. If the 640X Option is installed, remove the Bypass Flow Tube from the ASC tube and cap the Bypass Tube fitting.
5. Connect the Flow Standard to the top of the Upper Inlet Tube. Wait at least one minute for the flow to re-stabilize.
6. With the T640 running, go to the Calibration>Sample Flow Cal menu.
7. Compare the “Measured Flow” in this screen to the Flow Standard.
8. If these values differ by more than 5%, then press the value button in the “Actual Flow” field, enter the value measured by the Flow Standard, and press the “Calibrate” button on this screen. The Measured Flow value should change to closely match the Actual Flow within a few seconds.
9. For the T640 with the 640X Option, leave the Bypass Tube disconnected and proceed to the bypass flow calibration procedure in Section 4.4.
10. For the T640 without the 640X Option, leave the Sample Inlet off and proceed to the PMT adjustment procedure in Section 4.5.

When finished, make sure to re-plug in the external ambient temperature probe before returning to normal sampling.

4.4. BYPASS FLOW CAL (11.67-LPM)

(Note: This procedure only applies to the 640x option)

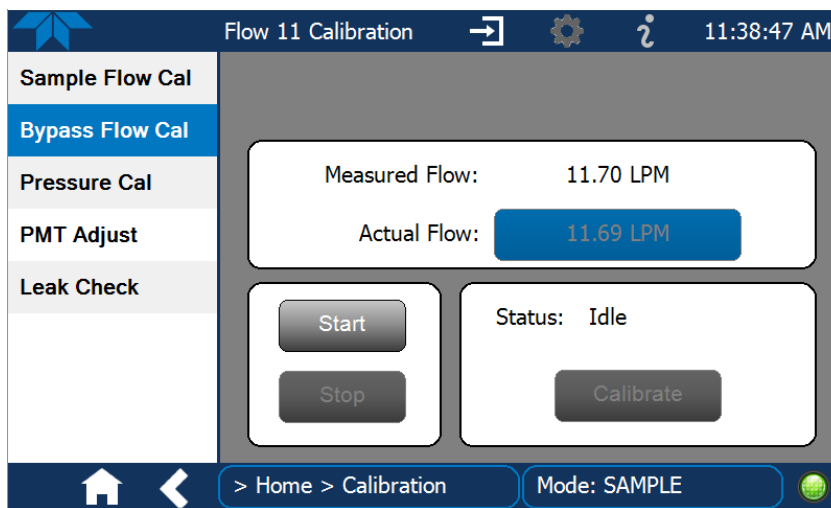

Figure 4-4. Bypass Flow Cal Menu

IMPORTANT

IMPACT ON READINGS OR DATA

Perform Pressure Cal first (Section 4.1).

Also, avoid using NIST-reference devices that cause a pulsation (i.e. BIOS) as these will disrupt the T640 flow control feedback system. Devices that create a constant and small pressure drop are preferred.

1. Connect the NIST-traceable flow transfer standard device to the Bypass Tube that was disconnected in the Sample Flow Cal procedure above. Wait at least one minute for the flow to re-stabilize.
 - If running the calibration indoors at the point of the bypass flow line, make sure the short ambient temperature probe is plugged into the rear panel so the flow standard and the instrument are measuring temperature in the same location.
2. With the T640 running, go to the Calibration>Bypass Flow Cal menu.
3. Compare the “Measured Flow” in this screen to the Flow Standard.
4. If these values differ by more than 5%, then press the value button in the Actual Flow field, enter the value measured by the Flow Standard, and press the Calibrate button on this screen.

The Measured Flow value should change to closely match the Actual Flow within a few seconds.

Make sure to re-plug in the external ambient temperature probe before returning to normal sampling.

4.5. PMT ADJUSTMENT

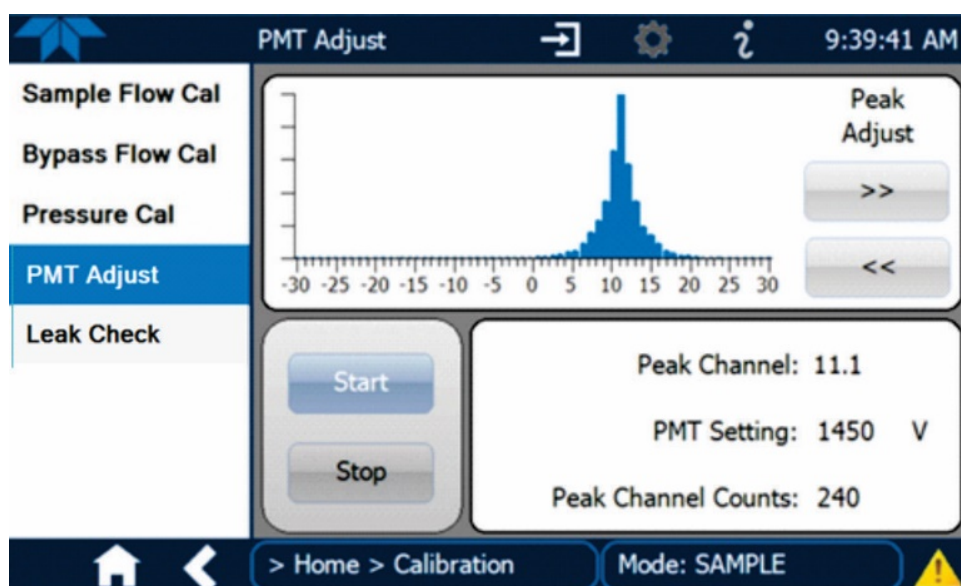

Figure 4-5. PMT Adjustment Menu

IMPORTANT

The Particle Sensor PMT Adjustment uses our SpanDust™, a monodisperse dust with a specific refractive index. All T640 instrument PMTs have a very specific response to this span dust which allows for the sensor to be checked and adjusted in the field for drift caused by contamination of the optics.

NOTE

This is not a calibration of the optical sensor based on the mass of dust being used, but simply a mechanism to check and adjust the PMT response to particles with a specific and known refractive index.

1. Navigate to the PMT Adjust screen.
2. Remove the T640 sample inlet or the 640X Option sample inlet and press the Start button on this screen to suspend normal data acquisition and start this adjustment process.
3. Prepare the SpanDust™ bottle by uncapping the “air intake” at the bottom of the silica gel drier attached to the bottle.
4. Place the tube from the SpanDust™ bottle into the top of the Upper Inlet Tube for the instrument.
5. Ensure that the silicone tube fits snugly inside the aluminum inlet tube, and do not allow the bottle to hang, as it could dislodge the silicone tube from the inlet tube.
6. Gently tap the SpanDust™ bottle to barely agitate the contents just enough to allow the dust to be pulled into the sensor, and allow 30 seconds for the Peak Channel reading in this screen to respond.
7. Note the Peak Channel value written on the SpanDust™ bottle. The typical value is 11.1 (*IMPORTANT: use the value displayed on the SpanDust™ bottle label with +/- 0.5 channel tolerance*), which will be used for example purposes below. If the bottle being used has a different peak value, follow the same procedure with the goal of peaking at that value.
8. If the Peak Channel reading is not at ± 0.5 compared with the value displayed on the SpanDust™ bottle, then adjust the PMT Setting by pressing the Peak Adjust left (decrement) or right (increment) buttons to center the Peak voltage. Each press of a button is 1 volt, so press the Peak Adjust button by as many times as the number of volts the reading is off.
9. Allow 30 seconds for the Peak Channel reading in this screen to respond, and if it is not at ± 0.5 (of the value displayed on the SpanDust™ bottle), repeat the process. This could take several tries over a long period when conducted in a humid environment.
10. Once the Peak Channel reading is at ± 0.5 of the value displayed on the SpanDust™ bottle, reattach the sample inlet and press the Stop button to stop the adjustment process and resume normal data acquisition.

4.6. LEAK CHECK

Use this operation when a leak is suspected or when performing preventive maintenance. Please see Section 5.2.8 for performing this operation.

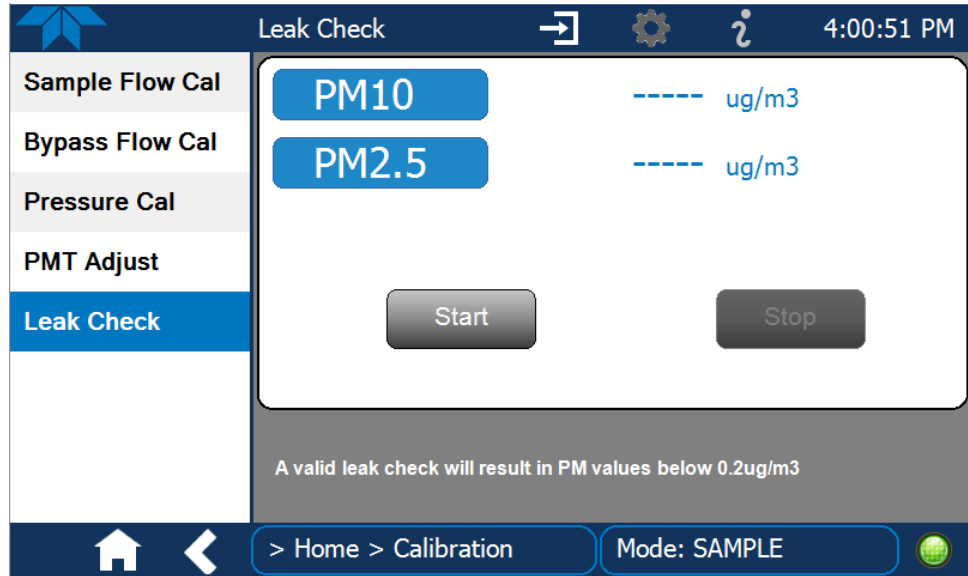

Figure 4-6. Leak Check Menu

5. MAINTENANCE AND SERVICE

This section presents the maintenance schedule and procedures.

5.1. MAINTENANCE SCHEDULE

As a part of routine system management, preventive maintenance includes cleaning, inspections, adjustments and calibrations. Table 5-1 provides a list of actions to take and their frequencies. Section 5.2 describes procedures.

Table 5-1. Maintenance Schedule

MAINTENANCE ACTION	FREQUENCY	REFERENCE
Clean Inlet	Monthly, or as needed	5.2.1 or 5.2.2
Check/Adjust PMT with SpanDust™ (measured peak, limit value displayed on SpanDust™ bottle ± 0.5)	monthly or as needed e.g., high dust load	4.5
Check Pump Performance (Pump PWM < 80% / Valve PWM value < 85%)	monthly	5.2.4
Flow Rate Verification (see below)		
T640 Sample Flow: 5.0 LPM +/- 5% of standard compared to current reading on T640; (e.g., 4.75 – 5.25 lpm if T640 reads 5.00).	Monthly	5.2.5
T640x Total Flow: 16.67 LPM +/- 5% of standard compared to current reading on T640x. (e.g., 15.87 – 17.54 lpm if T640x reads 16.7).	Monthly	5.2.5
T640x Bypass Flow: 11.67 LPM +/- 5% of standard compared to reading on T640x; (e.g., 11.12 – 12.29 lpm if T640x reads 11.7).	Monthly (As needed if total or sample flow does not meet criteria. Use same tolerance as total and sample flow)	5.2.5
Check for leaks with “zero” filter	Monthly or as needed (Acceptance criteria is 0.0 – 0.2 µg/m ³)	5.2.8
Inspect and clean optical chamber and RH/T sensor.	every six months or as needed, e.g., high dust load	5.2.6
Change disposable Filter Unit (DFU) for 5-LPM flow and bypass flow (if installed)	Annually, or when Pump PWM Value approaches 80%.	5.2.3
Inspect inner and outer sample tubes	Monthly or as needed	5.2.7

5.2. MAINTENANCE PROCEDURES

This section provides cleaning and maintenance information for the inlets and filters.

5.2.1. CLEANING THE T640 INLET

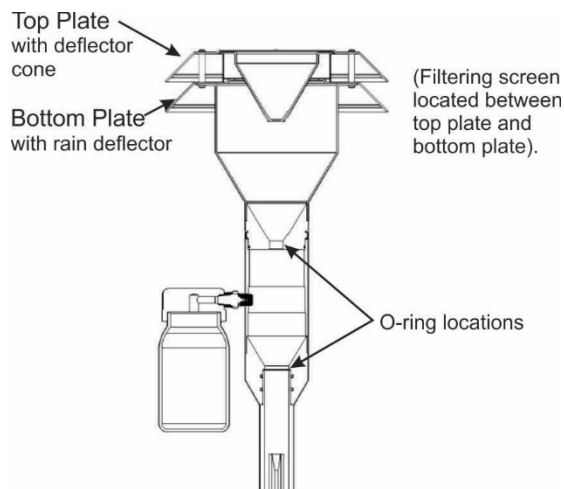

Figure 5-1. T640 Inlet (standard)

1. Power off the pump from the Setup>Vars>Pump Control menu. Pump choices are 'auto', 'off, and 'cleaning cycle'. Press 'edit' and the 'off' to turn off the internal pump. (Note: 'cleaning cycle' is a mode that pulses the internal pump to help dislodge any obstructions between the optical cell and the internal DFU).
2. Remove the sampling inlet from the sampling line.
3. Place the flow audit adapter with HEPA filter on the downtube to minimize opportunity of dust entering the sample line and monitor.
4. Disassemble the sampling inlet: two screws at base of inlet and base plate.
5. Carefully and thoroughly remove any dust deposits from inside of the inlet.
6. Remove any insects or other debris from the filtering screen.
7. Clean all the components using water and a mild detergent, if necessary.
8. Dry all components thoroughly with a clean cloth and blow compressed air through nozzles.
9. Check and, if needed, replace the o-rings located on the outside and the inside of the base plate, and grease them with vacuum grease.
10. Re-assemble the sampling inlet, sliding the baseplate back into the base of the inlet body, making sure to line up with the screw holes. The screws should be put back in to hand-tight pressure.
11. Reconnect sampling line.
12. Power up the pump from the Setup>Vars>Pump Control menu.

This procedure should be repeated per the schedule in Table 5-1.

5.2.2. CLEANING THE US EPA PM10 INLET



640x Option Inlet Cross Section

Figure 5-2. 640X Option Disassembly

1. Power off the internal pump from the Setup>Vars>Pump Control menu. Pump choices are 'auto', 'off', and 'cleaning cycle'. Press 'edit' and the 'off' to turn off the internal pump. (Note: 'cleaning cycle' is a mode that pulses the internal pump to help dislodge any obstructions between the optical cell and the internal DFU).
2. Power off the bypass flow pump by unplugging it.
3. Remove the PM₁₀ sampling inlet from the downtube.
4. Disassemble the sampling inlet (four screws on the underside of inlet louvered plates).
5. Carefully and thoroughly remove any dust deposits from inside the inlet.
6. Remove any insects or other debris from the filtering screen.
7. Unscrew the top of sampling inlet from the base of the inlet to expose the PM₁₀ well.
8. Using a moist lint free towel or wipe, clean the inside base of the PM₁₀ well.
9. Using cotton tipped applicator (or similar) saturate the tip of the applicator with DI water and clean out each of the three nozzles in the PM₁₀ well.
10. Carefully inspect and remove any insects or spider webs. If there is a spider web present, make note of it on the "Monthly QC and Maintenance Checklist" sheet.
11. If needed, dry all components thoroughly with a clean cloth
12. Blow canned air through the three nozzles.
13. Inspect and clean, as necessary the bottom connection of the downtube with a lint free towel or wipe.
14. Inspect and clean the water collector if any debris or water are present.
15. Check and, if needed, replace the O-rings located on the outside and the inside of the base plate, and grease them with vacuum grease.

16. Carefully re-assemble the top and base of the sampling inlet, but do not overtighten.
17. Reconnect the PM₁₀ inlet to the sample line.
18. Power up the internal pump from the Setup>Vars>Pump Control menu.
19. Power up the bypass flow pump by plugging it back in

5.2.3. CHANGING THE DISPOSABLE FILTER UNIT (DFU)

1. Power off the pump from the Setup>Vars>Pump Control menu.
2. Pull open the instrument's front panel, using the front panel finger grips.



Figure 5-3. Opening the Front Panel

3. Noting its orientation, remove the old DFU by detaching from the pneumatic quick-connect fittings, and replace with a new DFU matching the orientation.

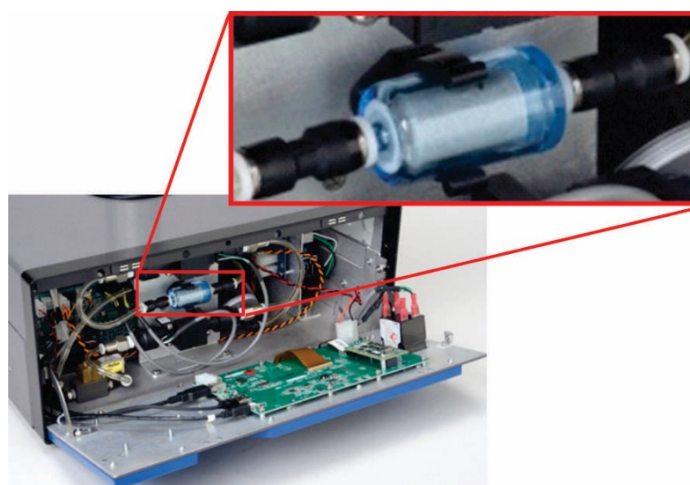

Figure 5-4. Internal DFU

4. For 640X Option only: noting its orientation, detach the filter from the quick-connect fittings and replace with new.



Figure 5-5. External DFU, (with 640X Option only)

5. Ensure the filter(s) is (are) seated snugly with no gaps, and power on the pump from the Setup>Vars>Pump Control menu.

5.2.4. CHECKING PUMP PERFORMANCE

There is one internal pump in the T640. In addition, the 640X Option has a separate external pump. The pump(s) and the valve (640X Option only) must maintain proper flow for measurement accuracy. Check their performance levels in the Dashboard (If these parameters are not found in the Dashboard, configure the Dashboard to add them; see Section 3.2.9):

- Pump PWM typically runs between 30% and 80%.
- Valve PWM typically runs between 50% and 85%.

If the performance levels are out of range, refer to Table 5-2 for troubleshooting guidance.

5.2.5. CHECKING THE VOLUME FLOW

Check the Sample Flow levels in the Dashboard. (If not found in the Dashboard, add it through the Dashboard configuration page; see Section 3.2.9). The typical EPA tolerance for flow is to be within 5% of the setpoint, which is +/- 0.25 LPM for the 5 LPM flow. If out of range (5 LPM, +/- .25 LPM), refer to Table 5-2 for troubleshooting guidance.

For the 640X Option, also check the Bypass Flow levels in the Dashboard. (If not found in the Dashboard, add it through the Dashboard configuration page; see Section 3.2.9). As mentioned above, the typical EPA tolerance for flow is to be within 5% of the setpoint, which is +/- 0.58 LPM for the 11.67 LPM flow. If out of range (11.67 LPM, +/- 0.58 LPM), refer to Table 5-2 for troubleshooting guidance.

If you have decoupled the T640 from the sample line via the slip coupler and are making the flow measurements indoors, make sure to use the provided “short temperature probe” in place of the standard ambient temperature probe during the flow audit. This is so that the T640 is referencing its flow to the indoor temperature the same as the flow standard. When finished with the flow check, make sure to plug the ambient temperature probe back into the instrument.

5.2.6. CLEANING THE OPTICAL CHAMBER AND THE RH/T SENSOR

1. Items needed: Phillips Head screw driver, 2.5mm Allen Wrench, Canned Air, cotton swabs, and dry, lint-free, non-abrasive wipes.

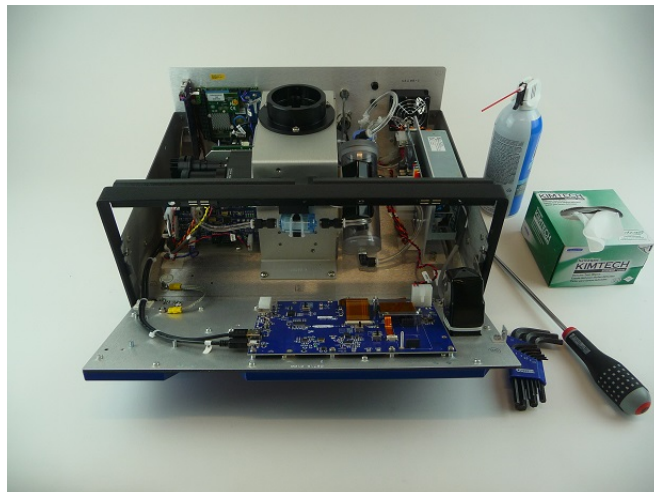

2. Remove the ASC support, which straddles the sensors.
 - Make note of all connections, electrical and plumbing, that go between the components on the ASC support and the rest of the instrument.
 - Unplug the flow sensor(s) from the front control board
 - Unplug the plumbing from parts that mate to components on the support (i.e. RH sensor to the DFU, Pulsation dampener to the pump, etc.).
 - There are four Phillips-head screws that secure the support to the floor of the instrument, two on each footing.

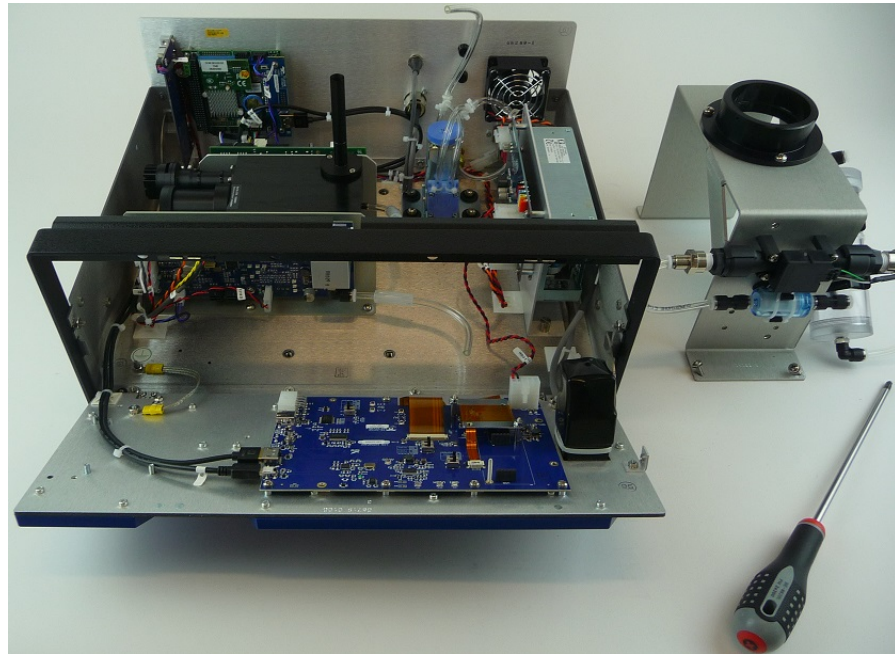

3. Locate the optical cell nozzle, the cup at bottom of optics chamber and its tubing, and the Relative Humidity and Temperature (RH/T) sensor.

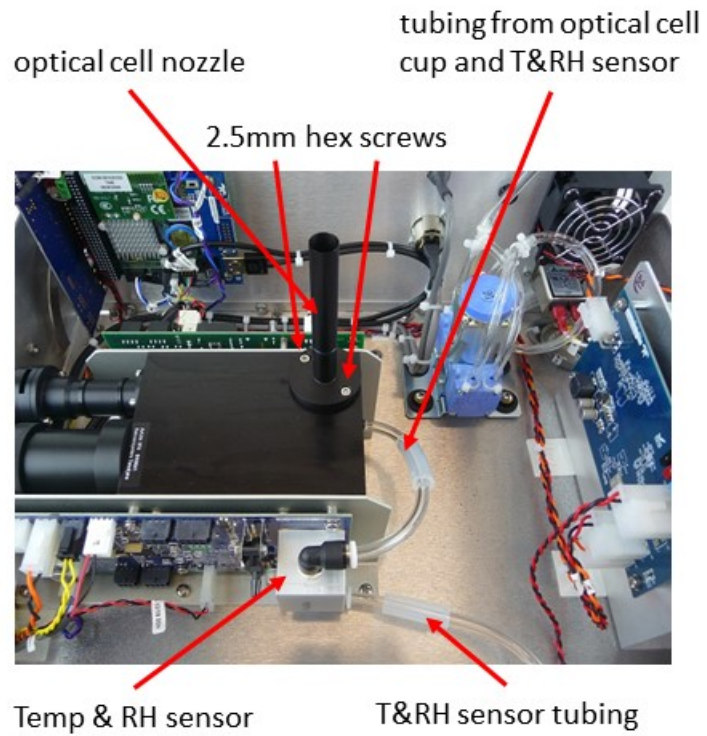

4. Remove optical cell nozzle from optics chamber, and remove cup, including its tubing, from optics chamber bottom; detach RH/T sensor tubing from the cup.

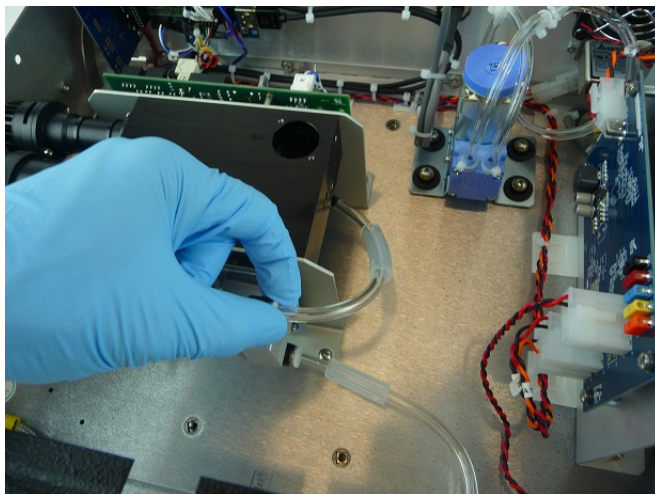
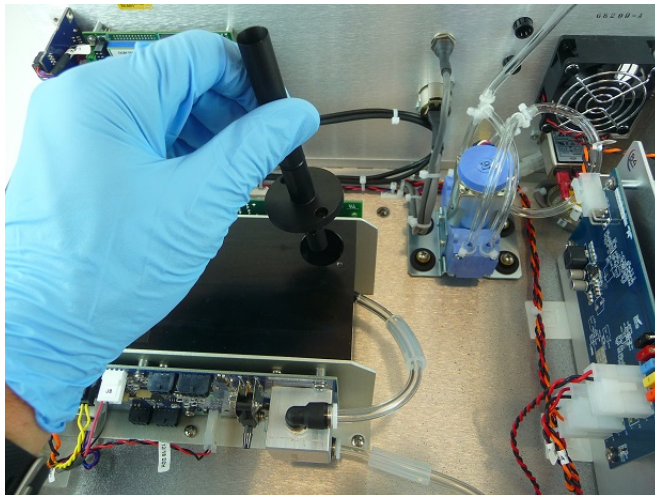
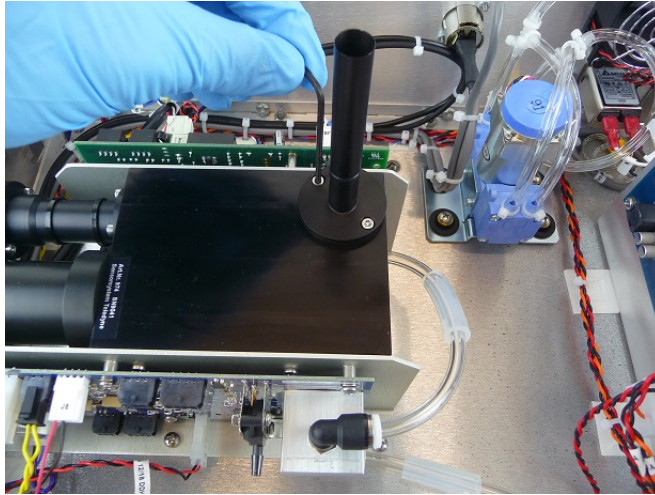

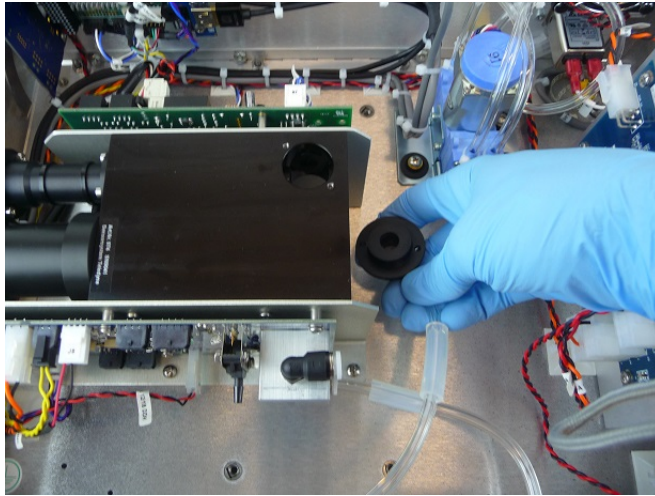

5. Clean the optics chamber interior surfaces, ensuring to include windows, with a lint-free cloth.



Figure 5-6. Maintenance: Optics Chamber Windows

6. Use a can of compressed gas made specifically for electronics to blow any dust or other debris from the optics chamber, from the cup, from the bottom of the optics chamber, and from the tubing.

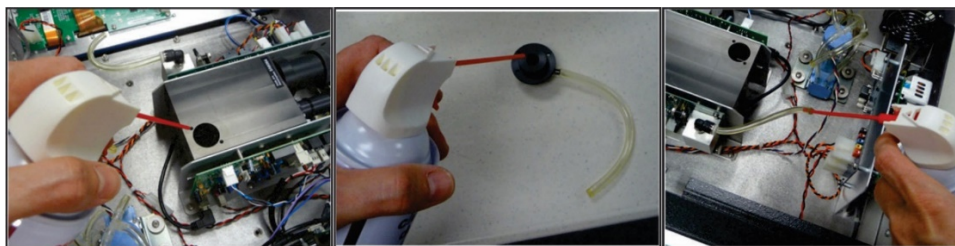
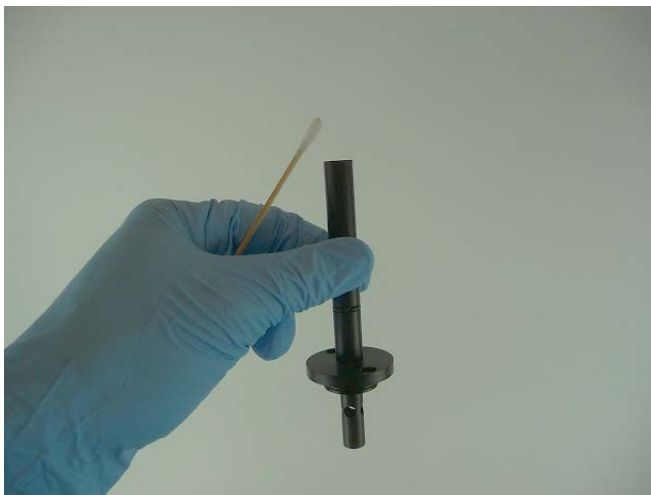
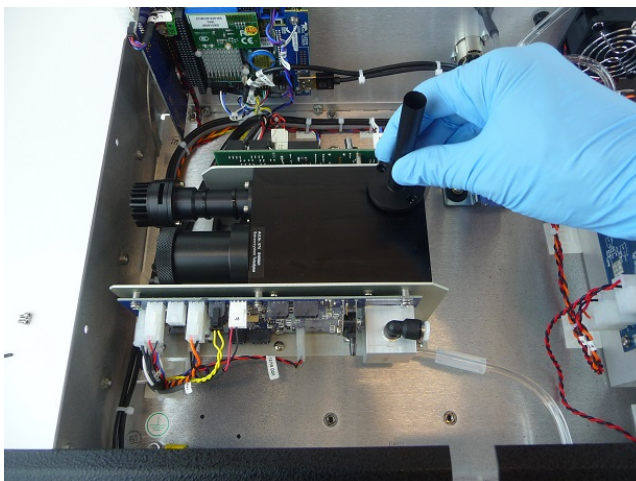

Figure 5-7. Maintenance: Final Dusting

7. Clean the optical cell nozzle using cotton swabs and canned air.



8. When finished, reassemble optics chamber components;
- Reinsert the nozzle to the top of the optical cell and tighten the screws to “hand-tight”. Do Not Overtighten the screws.
 - Install the cup to the bottom of optics chamber;
 - Reconnect tubing from cup in bottom of chamber to RH/T sensor
 - Reinstall the ASC support and the tubing from RH/T sensor to the DFU filter.
 - When re-installing the ASC support, the tubing from the optical cell cup to the DFU needs to be routed through the side (above the diagonal support) of the ASC support.
 - Pay special attention not to place the support on top of any wires near the rear-panel and CPU board. The harness should be out of the way, but it is a good idea to check.
 - Reconnect the flow sensor plugs to the front control board as well as any additional tubing that was unplugged (i.e. the pulsation dampener to the pump).



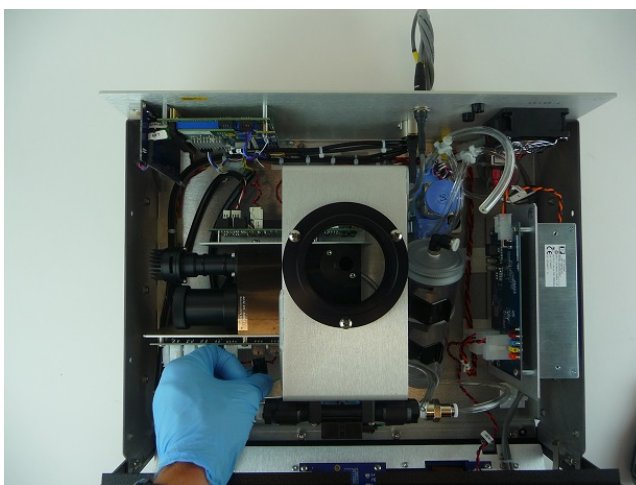
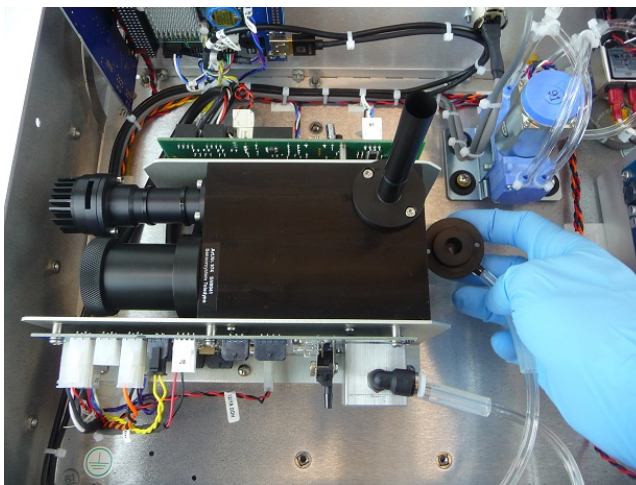

9. Close instrument and turn power on. Wait until the LED temperature stabilizes, and then perform a PMT sensor check with the SpanDust™ (Section 4.5).

5.2.7. INSPECTING THE SAMPLING LINE

Look inside the sampling line for debris or dust on the walls. If needed, push a rag or a paper towel through the line; then use a can of compressed gas made specifically for electronics to blow through the line for final cleaning.

5.2.8. CHECKING FOR LEAKS

The internal components of the T640 are not meant to be under strict vacuum as what would normally be done in a leak test. So, to avoid damage to internal components, it is recommended that the inlet never be capped (air tight) while the instrument pump is running.

The Leak Check (**Zero Test**) is a way to check for leaks that do not involve pulling a vacuum on the system.

1. Navigate to the Calibration>Leak Check menu (Figure 4-6).
2. Press Start.

3. Remove the sample line inlet and replace with the T640 leak check kit (084910000) or equivalent fitting with filter.
4. Within a few minutes, the PM values should be at zero; note the following:
 - PM values remaining below 0.2ug/m3 indicate that there are no leaks.
 - PM values remaining steady above 0.2ug/m3 indicate a possible leak in the sample line, above the optical sensor.
 - Check o-rings and proper installation of couplers and tubing.
 - It is also possible the HEPA filter being used is either bad or leaking. Always have a second filter handy to check.
5. When satisfied that the readings are stable and the condition has been determined, remove the HEPA filter from the sample line, replace the sample inlet, and then press “Stop” on the Leak Check screen.

5.3. TROUBLESHOOTING AND SERVICE

This section provides guidance for resolving fault conditions and possible flow and calibration problems.

5.3.1. FAULT DIAGNOSIS

The Alerts log may be useful in diagnosing faults. Table 5-2 lists some of the Alerts that are triggered by faults, describes their likely causes, and provides possible solutions.

Table 5-2. Alerts and Recommendations

MESSAGE	DESCRIPTION	POSSIBLE SOLUTION(S)
System Reset	Warning raised when the system is reset	Normal power cycle occurred? If not, check external power source.
Sample Flow Warning	The Sample Flow is outside the set limits	Check pneumatic fittings. Re-calibrate flow.
Bypass Flow Warning	The Bypass Flow is outside the set limits	Check pneumatic fittings. Re-calibrate flow.
Sample RH High	The Sample RH is above the set limit	Check if ASC is plugged in. Check control board if ASC control LED is illuminated. Check if water is in the sensor.
Check LED	If the LED temperature is equal to the box temperature, the LED may be OFF	Cycle power. Call Tech Support.
Check PMT	The PMT HV setting is out of range (800 – 2200)	Check Sensor with SpanDust™. Perform an optical chamber cleaning. Call Tech Support.
Sample Flow Slope Warning	The Sample Flow Calibration Slope is Out Of Range	Check pneumatics for leaks. Re-run flow calibration. Call Tech Support.
BYPS Flow Slope Warning	The Bypass Flow Calibration Slope is Out Of Range	Check pneumatics for leaks. Re-run flow calibration. Call Tech Support.
Check Int Pump	Check the internal pump if the Pump PWM value is > 80%	Check pneumatics for blockages. Check pneumatics for leaks. Check flow calibration.

MESSAGE	DESCRIPTION	POSSIBLE SOLUTION(S)
Check Ext Pump	Check the external pump and/or bypass flow control valve if Valve PWM > 85%	Replace pump. Check pneumatics for blockages. Check pneumatics for leaks. Check external pump. Check flow calibration. External pump, or bypass flow control valve may need replacing.
Sample Temp Warning	Sample Temperature Warning (>60°C)	Check ASC (is it latched ON?) Ensure proper climate and ventilation for instrument.
Box Temp Warning	Box Temperature Warning (>60°C)	Ensure proper climate and ventilation for instrument.
AMB Press Slope OOR	Ambient Pressure Calibration Slope is out of range	Check calibration (make sure units match calibration device). Replace pressure sensor. Call Tech Support.
Time Sync Failure	Unable to synchronize time with NTP server	Check network and/or internet connection
Internal Serial Failure	Internal serial communication error with sensor or control board	Check connections and wires to board(s). Call Tech Support.

5.3.2. FLOW PROBLEMS

If a flow auditing device indicates any problems with flow, check to ensure the following:

- all connections are seated tightly and evenly (no gaps)
- sensor inlet/nozzle, ASC, and/or sample line are not clogged or blocked.
- pump is running and is within its PWM range (35% - 80%).

After making any adjustments, run a flow calibration and recheck the flow rate. If problems persist, please contact Technical Support.

5.3.3. CALIBRATION PROBLEMS

Call our Technical Support Department for technical assistance.

5.3.4. TECHNICAL ASSISTANCE

If this manual and its troubleshooting / service sections do not solve your problems, technical assistance may be obtained from:

Teledyne API Technical Support
9970 Carroll Canyon Road
San Diego, California 92131-1106 USA

Toll-free Phone: 800-324-5190
Phone: +1 858-657-9800
Fax: +1 858-657-9816
Email: sda_techsupport@teledyne.com
Website: <http://www.teledyne-api.com/>

Before contacting Teledyne API Technical Support, fill out the problem report form in the Appendix, which is also available online for electronic submission at <http://www.teledyne-api.com> under Technical Support Forms.

6. PRINCIPLES OF OPERATION

The Model T640 PM Mass Monitor is an optical aerosol spectrometer that converts optical measurements to mass measurements with sharp accuracy by determining sampled particle size via scattered light at the single particle level according to Lorenz-Mie Theory.

Briefly, the sampling head draws in ambient air with different-sized particles, which are dried with the Aerosol Sample Conditioner (ASC) and moved into the optical particle sensor where scattered light intensity is measured to determine particle size diameter. The particles move separately into the T-aperture through an optically differentiated measurement volume that is homogeneously illuminated with polychromatic light. The polychromatic light source, an LED, combined with a 90° scattered light detection achieves a precise and unambiguous calibration curve in the Mie range, resulting in a large size resolution.

Each particle generates a scattered light impulse that is detected at an 85° to 95° angle where amplitude and signal length are measured; the amplitude (height) of the scattered light impulse is directly related to the particle size diameter.

The T-aperture and simultaneous signal length measurements eliminate border zone error, which is characterized by the partial illumination of particles at the border of the measurement range.

6.1. SAMPLING SYSTEM

There are several components that are part of drawing in and measuring aerosol samples: the inlet, the Aerosol Sample Conditioner (ASC), an optical particle sensor, a flow sensor, and pump.

6.1.1. INLET

The inlet for the T640 is designed to allow complete transmission of all particle sizes.

The US EPA PM₁₀ inlet used for the 640X Option samples at 16.67-LPM to mechanically size-cut the aerosol intake for sampling particles at 10 microns and under.

6.1.2. AEROSOL SAMPLE CONDITIONER (ASC)

The ASC removes volatile components (mainly water) of the aerosol to avoid false particle size. Its operation includes an air sensor for measuring ambient temperature and humidity in order to dynamically adjust the heating of the ASC tube for moisture/humidity compensation.

6.1.3. OPTICAL PARTICLE SENSOR

The optical particle sensor is the main sensor in the instrument. This sensor analyzes the particles, categorizing them by size and making the conversion to a mass concentration.

6.1.4. FLOW SENSOR AND PUMP CONTROL

The T640 operates using ambient temperature and pressure compensated mass flow, for accurate control of flow to actual volumetric conditions. The flow stream is measured (main flow at 5 LPM for T640 and bypass at 11.67 for 640X Option), and a feedback loop triggers the pump drive voltage adjustments to maintain a constant flow (5 LPM in the T640, 16.67 LPM in the 640x Option).

The internal vacuum pump is a 24V DC pump controlled by a pulse-width modulation (PWM) feedback control for consistently accurate flow through the sensor.

The external vacuum pump (640X Option only) uses either a 110-120 or 220-240VAC pump. The bypass flow is controlled at 11.67 LPM by a proportional-integral-derivative (PID) feedback control for consistently accurate flow through the PM₁₀ inlet. The combined flow of the internal pump at 5 LPM along with the bypass flow at 11.67 LPM make up the necessary 16.67 LPM for the US EPA PM₁₀ inlet proper size cut.

6.2. ELECTRONIC BLOCK DIAGRAM

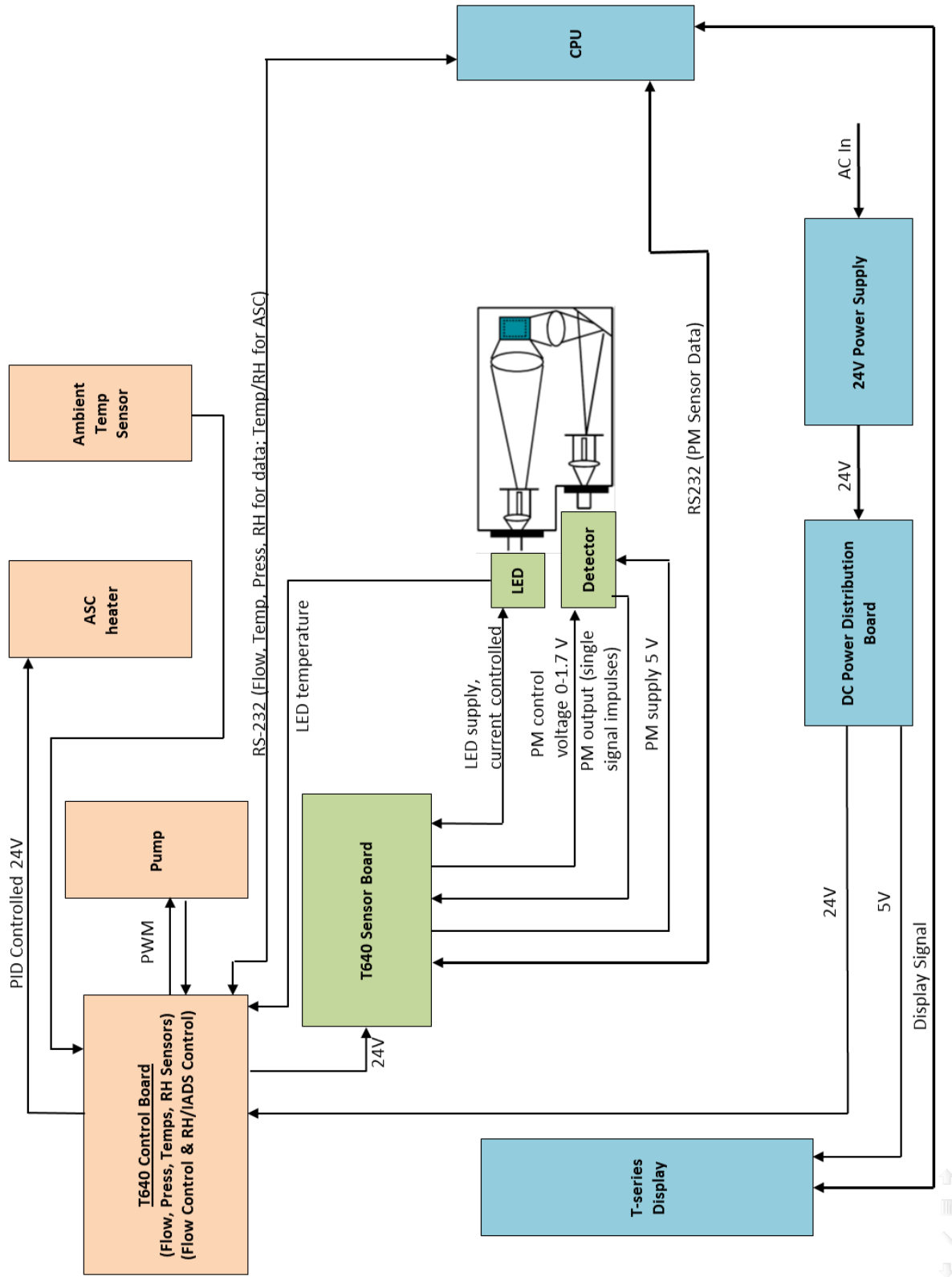

Figure 6-1. T640 with 640X Option Electronic Block Diagram

APPENDIX A – WARRANTY REPAIR QUESTIONNAIRE

(Reference 08343B DCN7303)

CUSTOMER: _____ PHONE: _____

CONTACT NAME: _____ FAX NO. _____

SITE ADDRESS: _____

MODEL TYPE: _____ SERIAL NO.: _____ FIRMWARE REVISION: _____

Are there any failure messages?

PLEASE COMPLETE THE FOLLOWING TABLE FOR THE T640:

PARAMETER	RECORDED VALUE	ACCEPTABLE VALUE
Sample Flow	LPM	5.0LPM \pm 5%
Sample Flow Slope		0.85 – 1.15
Ambient Pressure		Within +/- 10mmHg of audit device
Sample RH	%	\leq 50% (typically \leq 35% controlled by ASC)
Box Temp	$^{\circ}$ C	0-60 $^{\circ}$ C
Ambient Temp	$^{\circ}$ C	-40 - 60 $^{\circ}$ C
LED Temp	$^{\circ}$ C	\leq 70 $^{\circ}$ C
Sample Temp	$^{\circ}$ C	0 – 60 $^{\circ}$ C
P3 Value		45 - 55
PMT HV Setting	V	1100 – 2200V
Pump PWM		<80%
640x Valve PWM		<85%
640x Option Bypass Flow	LPM	11.67 (\pm 5%)
640x Option Bypass Flow Slope		0.85 – 1.15

* Used for diagnostics only and should not be set/reset without explicit direction from TAPI Tech Support. If P3 (Calculated) does not appear in the Dashboard, configure the Dashboard (Section 3.2.9) to display it.

What is the measured Sample flow rate? _____ liters/min

What are the failure symptoms? _____

What tests have you done in trying to solve the problem? _____

Thank you for providing this information. Your assistance enables Teledyne API to respond faster to the problem that you are encountering.

OTHER NOTES: _____

TELEDYNE API TECHNICAL SUPPORT

Email: sda_techsupport@teledyne.com

PHONE: +1 858-657-9800 TOLL FREE: (800) 324-5190 FAX: +1 858-657-9816

APPENDIX B – MENU HIERARCHY

This section provides a high-level breakout of the NumaView™ software interface menu structure.

Home

Dashboard

Alerts

Calibration

- Sample Flow Cal
- Bypass Flow Cal
- Pressure Cal
- PMT Adjust
- Leak Check

Utilities

- Datalog View
- Alerts Log
- USB Utilities
 - General
 - DAS Download

Setup

- Data Logging
- Events
- Dashboard
- Vars
 - (list of various features and functions with editable settings)
- Homescreen
- Instrument
 - Product Info
 - System Info
 - Network Settings
 - Date/Time Settings
 - NTP Time Settings
 - Language
 - Remote Update
- Comm
 - TCP Port1
 - TCP Port2
 - Network Settings