



MODEL T108
TOTAL-SULFIDES-IN-CO₂ ANALYZER
WITH MODEL 501TS THERMAL CONVERTER

Addendum to T100 Operation Manual, PN 06807

Also supports operation of:

Model T108U Analyzer

(when used in conjunction with both the T100 manual, PN 06807, and
the T100U addendum, PN 06840)

© TELEDYNE API (TAPI)
9970 Carroll Canyon Road
SAN DIEGO, CA 92131-1106
USA

Toll-free Phone: 800-324-5190
Phone: +1 858-657-9800
Fax: +1 858-657-9816
Email: api-sales@teledyne.com
Website: <http://www.teledyne-api.com/>

ABOUT THIS MANUAL

This T108 addendum is to be used in conjunction with the T100 operation manual. It also supports the T108U analyzer when used in conjunction with both the T100 manual and the T100U manual.

Note

**We recommend that all users read this manual in its entirety before
operating the instrument.**

This page intentionally left blank.

TABLE OF CONTENTS

1. INTRODUCTION.....	5
1.1. Specifications	5
1.2. The T108 Total-Sulfides-in-CO ₂ Analyzer.....	5
1.3. Configurations	6
1.4. The 501TS – Total Reduced Sulfur Converter.....	10
1.4.1. Heater Characteristics and Control	10
1.5. Installation	12
1.6. Operation and Calibration.....	13
1.6.1. CO ₂ Source.....	14
1.7. TS and Zero Air Scrubbers.....	14
1.8. 501TS Temperature Controller.....	14
2. TROUBLESHOOTING AND SERVICE.....	15
2.1 SO ₂ Analyzer Maintenance.....	16
2.2 Changing the Quartz Tube	16
2.3 Checking the Converter Efficiency.....	16
2.4 Sample Diluter Maintenance	17
2.5 Thermocouple Replacement	18
2.6 Technical Support	20
3. INSTRUMENT TEST & CALIBRATION RECORD.....	21

List of Figures

Figure 1-1. Basic Pneumatics Configuration.....	7
Figure 1-2. Pneumatics with IZS/Permeation Tube Option.....	8
Figure 1-3. Pneumatics with 702 Calibrator Option	9
Figure 1-4. 501TS Converter Chassis Layout.....	11
Figure 1-5. T108-to-501TS Rear Panel Pneumatic Connections	13
Figure 1-6. 501TS Controller Interface.....	14
Figure 2-3. Diluter Flow Block Assembly	17
Figure 2-4. Thermocouple	18
Figure 2-5. Quartz Tube Cavity for Thermocouple.....	19
Figure 2-6. Thermocouple Installed.....	19
Figure 2-7. Tie-Wrap Hold-Down Location.....	20

List of Tables

Table 1-1. 501TS Converter Specifications	5
Table 3-1. Final Test and Calibration Values for T108.....	21
Table 3-2. Test and Calibration Values for T108U.....	22
Table 3-3. Test and Calibrations Values w/ CO ₂ where applicable.....	23

APPENDIX A - 501-TRS Interconnect Drawing (see T101 manual 07267 for T10X Interconnects)

This page intentionally left blank.

Since the gas being analyzed is essentially CO₂, which generally contains no oxygen, the analyzer includes an oxygenator to add approximately 6% oxygen to the sample before it passes through the converter. This dilution of the sample gas is compensated by the software and calibration procedure. The added oxygen allows the sulfur compounds to be oxidized to SO₂ making the T108 respond to the total number of sulfur molecules in the sample gas. Any SO₂ present in the sample is unaffected by the converter and adds to the measured concentration. The sample gas then passes to a modified T100 analyzer where the SO₂ and converted compounds are analyzed as SO₂.

1.3. CONFIGURATIONS

There are three configurations available: the standard analyzer and two with options.

Configuration	Description
Standard	<ul style="list-style-type: none"> • modified T100 Fluorescent SO₂ Analyzer • 501TS High Temperature Thermal Converter • External Span, Internal Zero with High-performance Charcoal Scrubber for Zero. <p>See Figure 1-1 for the pneumatic diagram, and Section 1.4 for details on operation of the 501TS.</p>
Standard + IZS	<p>Internal Zero/Span (IZS) Option with H₂S permeation tube.</p> <p>The IZS option uses sample gas (passed through a special, high-performance charcoal scrubber) to dilute H₂S from the perm tube for span calibration checks.</p> <p>See Figure 1-2 for the pneumatic diagram.</p>
Standard + Model 702 Calibrator	<p>The Model 702 calibrator option blends tanks of H₂S span gas with the processed CO₂.</p> <p>See Figure 1-3 for the pneumatic diagram.</p>

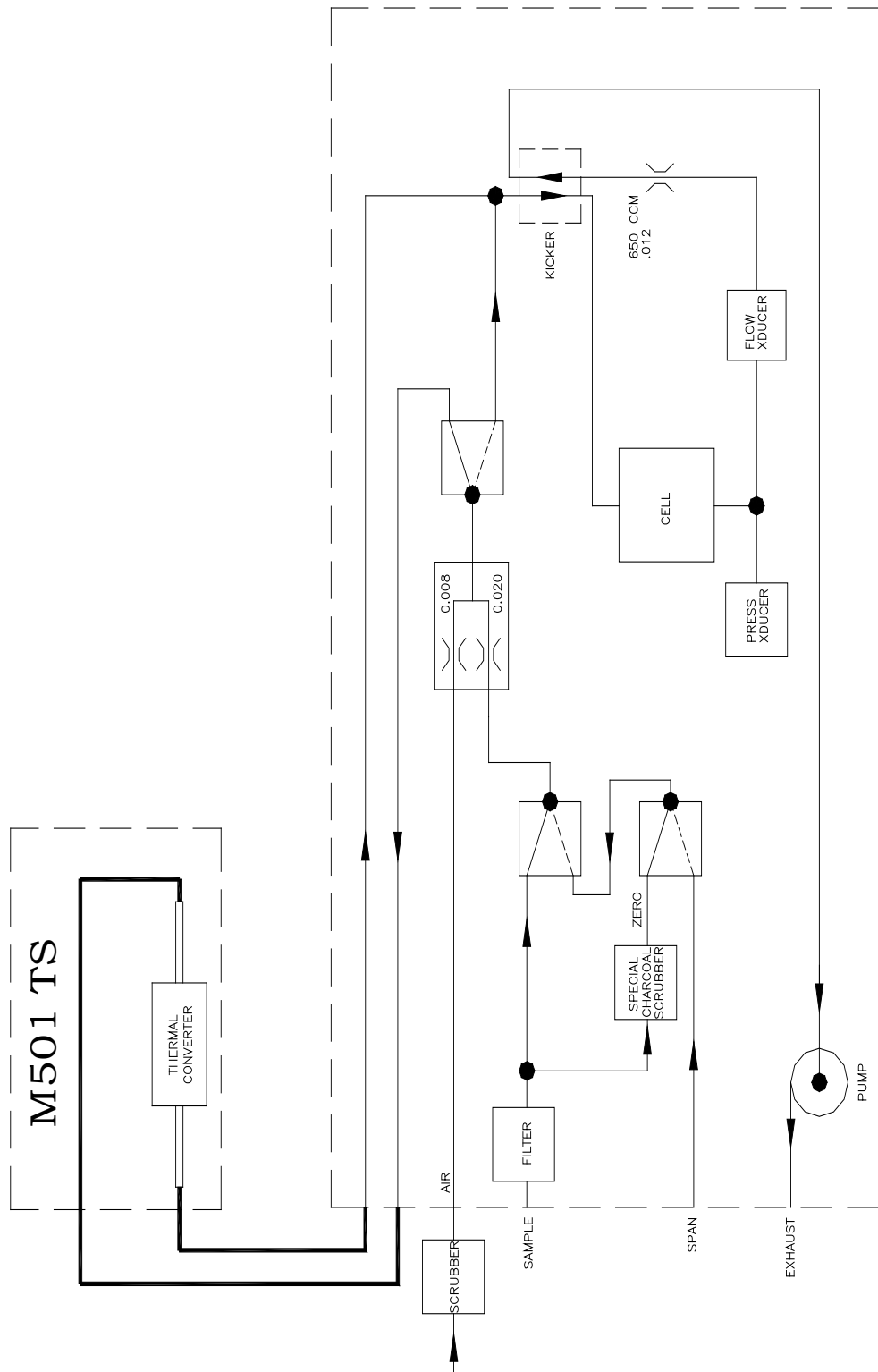

Figure 1-1. Basic Pneumatics Configuration

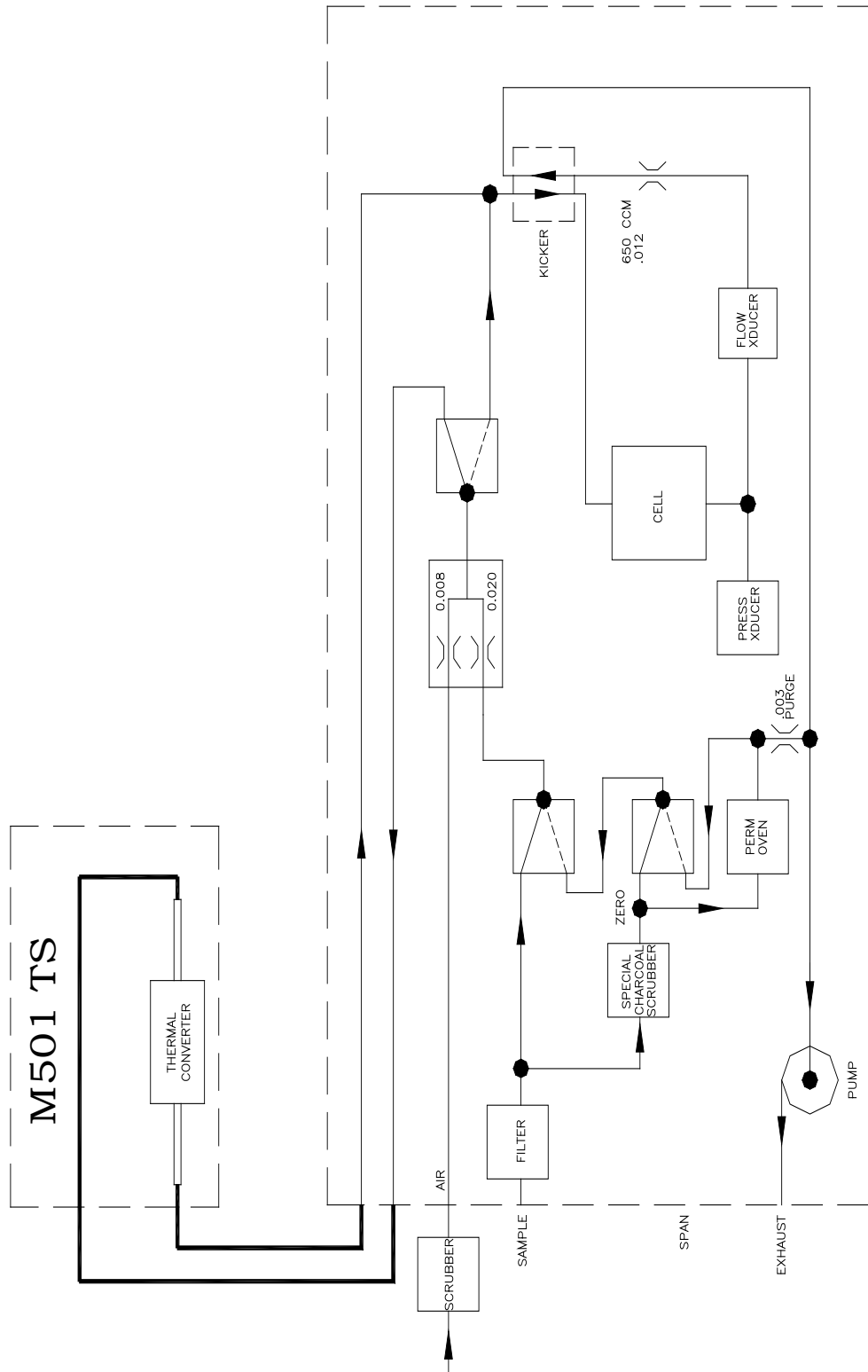

Figure 1-2. Pneumatics with IZS/Permeation Tube Option

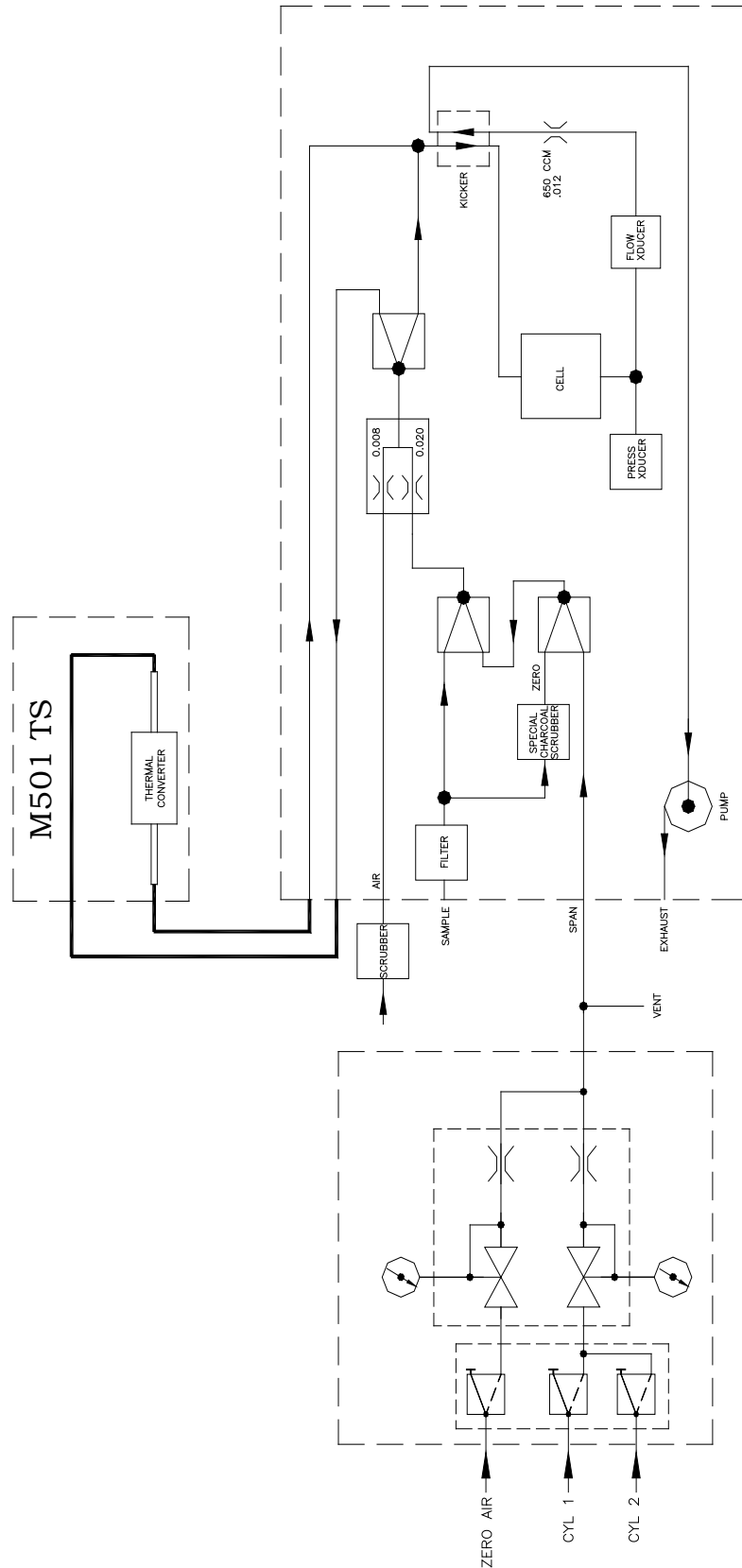

Figure 1-3. Pneumatics with 702 Calibrator Option

1.4. THE 501TS – TOTAL REDUCED SULFUR CONVERTER

The 501TS oxidizes reduced sulfur compounds to SO₂ in a high temperature quartz oven.

1.4.1. Heater Characteristics and Control

A front-panel-mounted, programmable digital temperature controller regulates power to the heater.

- Power to the heater is switched by a solid state, zero-crossing relay.
- An over/under-temperature alarm contact closure is located on the rear panel.
- The alarm set point has been preset in the temperature controller.
- The heater temperature is sensed by a Type S (distinguished from other thermocouple types by its wire colors, red and black) (Platinum-Rhodium) thermocouple probe inserted in the bore alongside the quartz tube.



CAUTION!
Do not use any other type thermocouple, as the controller settings have been preset for Type S.

The quartz tube carrying the sample mixture runs through the core of the heater and is heated by radiation from electrical heating elements at the heater bore surface. See Figure 1-4 for a layout view of the converter.



WARNING!
Ensure proper line voltage is selected prior to plugging unit into the power source.



CAUTION!
Do not touch – the quartz tube and heater are very hot.

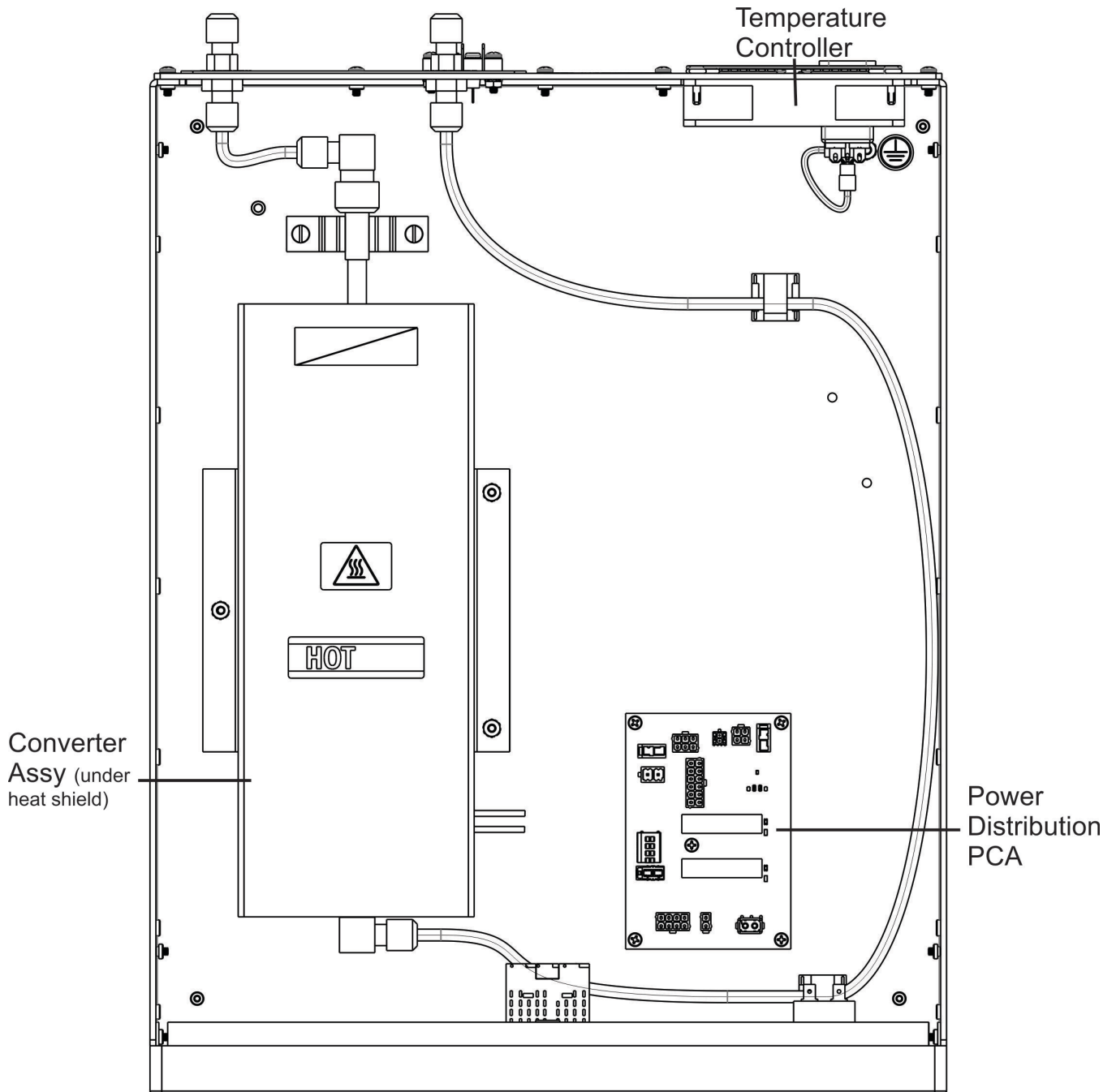

Figure 1-4. 501TS Converter Chassis Layout

1.5. INSTALLATION

The T108 consists of two chassis: the analyzer and the converter. There is a power cord for each that should be plugged into the correct AC mains receptacle. See the model label on the rear panel of each chassis for the voltage and frequency configuration. The power connection must be made with an approved three-wire-grounded power cord.

The pneumatic connections are shown in Figure 1-5 .

- Connection to the TS analyzer must be made with Teflon tubing.
- Connect the sample inlet to the labeled fitting.
- The sample exhaust must be routed to a well-ventilated area away from the air inlet for the zero air scrubber on the rear panel.



CAUTION! Ensure proper ventilation to the converter!
Do not block the side or the back of the Model 501 TS Converter!

The overall pneumatic diagrams of the Model T108 are shown in Figure 1-1, Figure 1-2 , and Figure 1-3.



CAUTION!
Do not operate without the 501TS converter's cover in place! Oven temperature will not regulate properly without cover properly installed.

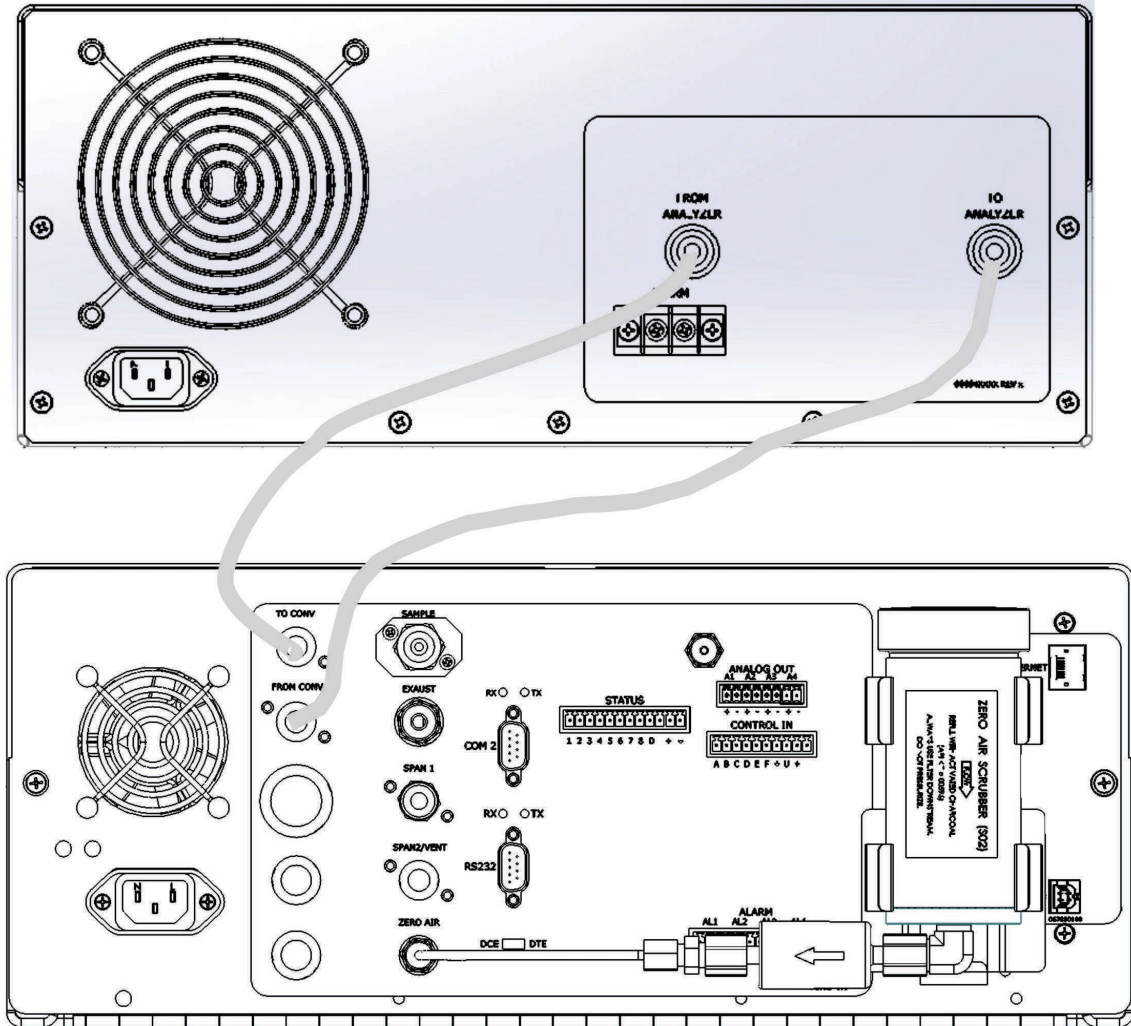

Figure 1-5. T108-to-501TS Rear Panel Pneumatic Connections

1.6. OPERATION AND CALIBRATION

Refer to the T100 manual for the overall operation of the SO₂ analyzer. This unit has some unique operating characteristics and calibration procedures detailed below.

The basic purpose of this instrument is to analyze CO₂ sample gas for sulfur containing impurities. Typically, the impurities should be at low levels; therefore, it is especially important that the zero calibration of the analyzer is done accurately so that even small levels of impurities can be detected.

1.6.1. CO₂ Source

A source of CO₂ that is free of sulfides is required for accurate zero calibration of the instrument. If the ‘zero gas’ used to zero the instrument is contaminated, the process gas will read artificially low, sometimes even showing a negative TS concentration. Standard CO₂ bottles can have unacceptably high levels of sulfur compounds in them. Beverage grade CO₂ should be used as a diluent as well as the ‘zero gas’ source for calibration of the T108.

Since CO₂ strongly quenches the SO₂ fluorescence reaction, the instrument sensitivity will be greatly reduced when using CO₂ as the balance gas. Therefore, it is imperative that the T108 be calibrated using CO₂ as the balance gas when it will be measuring TS in a gas matrix that is primarily CO₂.

CO₂ liquefies when compressed, and sulfur compounds do not stay dissolved in liquid CO₂. Therefore it is not practical to use compressed gas bottles of H₂S in CO₂ for calibration purposes. TAPI strongly recommends that H₂S in N₂ bottles be used for calibration of the T108, and that a calibrator be used to mix zero gas (CO₂) into the cal gas stream, making the final calibration gas mostly CO₂.

1.7. TS AND ZERO AIR SCRUBBERS

There are two charcoal scrubbers in the analyzer chassis of the T108. The scrubber canister on the outside of the rear panel of the analyzer is a standard charcoal scrubber that supplies zero air for the diluter assembly. The second scrubber is located inside the analyzer behind the sample filter. This scrubber uses a specially impregnated charcoal (TAPI Part# CH_52) which is especially effective in scrubbing TS gasses. This filter is used to scrub TS from the inlet sample gas for use in zero calibrating the analyzer.

1.8. 501TS TEMPERATURE CONTROLLER

A front-panel-mounted, programmable controller maintains the heater temperature. The manual for the controller is included with the documentation for this instrument. The controller has been set up at the factory and should not need adjustments, but if deemed necessary, please contact Technical Support (see Section 2.6).

To view the actual temperature, PV – Present Value, or the set point value, SV – Set-point Value, press the PV/SV button in the lower left corner of the controller. If a different set point value is required or to perform the Auto Tune function, please contact Technical Support (Section 2.6).

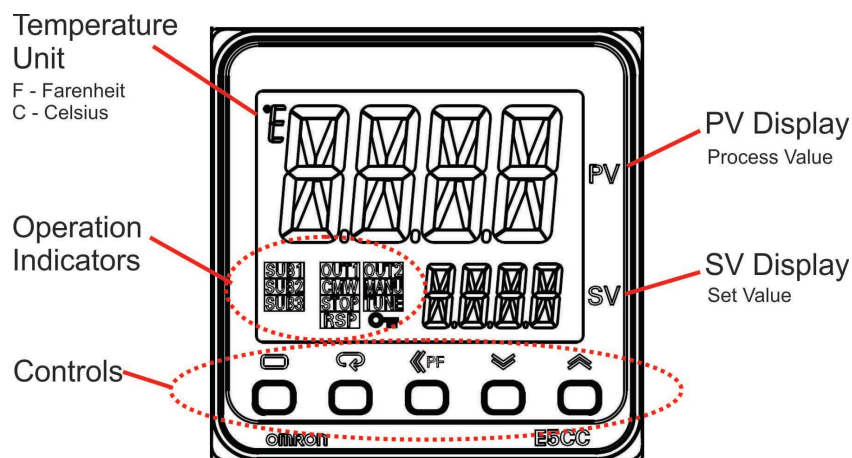

Figure 1-6. 501TS Controller Interface

2. TROUBLESHOOTING AND SERVICE

NO POWER:	Plugged in? Switched on? Circuit breaker tripped?
NOT HEATING:	View the PV value. Is it heating? Socket in place on back of temperature controller? Check 501TS wiring diagram in Appendix A. Thermocouple failed? Check that its leads are securely connected to the wiring block at the back of the controller. Also, check the thermocouple resistance across the leads for opens or shorts.
TS ANALYZER UNSTABLE:	Leak-check per analyzer main manual.
EFFICIENCY <90%:	Leaking? Leak-check. Plugged? Compare flow through and bypassing converter. Flow too high? Span gas correct? Contaminated? Check inside of Teflon tubing
CONVERTER TEMP UNSTABLE:	Contact Technical Support (Section 2.6).

2.1 SO₂ ANALYZER MAINTENANCE

Maintenance of the SO₂ analyzer is covered in the Maintenance section of its respective manual. Unlike the T100, the T108 has one standard charcoal scrubber on the rear panel of the SO₂ analyzer instrument chassis, and another special charcoal scrubber inside the chassis. The zero calibration (and thus the overall accuracy of the instrument) is dependent on high quality zero air.

IMPORTANT

Make sure that the charcoal is replaced at the 3-month interval suggested in the T100 maintenance schedule. Also be sure not to mix charcoal between the inner and outer scrubber canisters, they are different materials.

2.2 CHANGING THE QUARTZ TUBE

1. Turn off 501TS and allow it to cool to room temperature (~2 hours).
2. See Figure 2.4. – 501TS Layout
3. Remove the screws from the top inside of the front panel and fold panel downward.
4. Loosen front and rear fittings at each end of the tube.
5. Carefully slide the tube out of the heater – the ceramic bushings at each end of the heater are very fragile.
6. Slide the new tube into the heater, and re-connect the fittings.
7. Leak check the unit.
8. Replace the thermocouple making sure that it is fully inserted into the indentation in the body of the quartz tube.
9. Check the converter efficiency. See Section 4.3

2.3 CHECKING THE CONVERTER EFFICIENCY

After maintenance it is good practice to check the converter efficiency. To check the converter efficiency, perform the following procedure:

1. Produce a calibration gas of 400 ppb H₂S in CO₂ at a flow greater than the demand of the instrument; vent the excess gas out of the room.
 - When using a calibrator or gas blender to generate H₂S span gas (either permeation tube or tank) with CO₂ gas as the diluent, please remember that rotameters and mass flow controllers are calibrated with air or nitrogen. Using them with CO₂ will produce large calibration errors (as large as 30% or more), since CO₂ gas has considerably different characteristics. Contact the manufacturer of your mass flow measurement/control device for instructions on how to

use it to measure CO₂ flow. Or use a flowmeter such as a soap bubble, or BIOS – DryCal flowmeter that measures volume flow

2. Allow the T108 to stabilize at span for at least 30 minutes.
3. Check the converter efficiency by adjusting the converter's temperature controller set point:
 - Starting at the converters normal set-point of 1000 °C, lower the set-point temperature of the Converter in 5 °C increments (allowing 10 minutes minimum settling time between increments) until a drop of approximately 5% of Full Scale is observed. Note the Thermal Converter temperature at this point.
 - Verify that the converter efficiency does not drop by 5% until the temperature has dropped by at least 40 °C,
 - Return the temperature set point to 1000 °C.

2.4 SAMPLE DILUTER MAINTENANCE

The sample diluter is used to inject a small amount of ambient air into the sample stream to provide oxygen for the converter. The diluter is located on the inside rear panel of the SO₂ analyzer. It consists of a stainless steel block and 2 orifices to control the amount of sample and air that is blended.

There should be no periodic maintenance required on this assembly, but a diagram (Figure 2-1) is included in case rebuilding of this assembly is required.

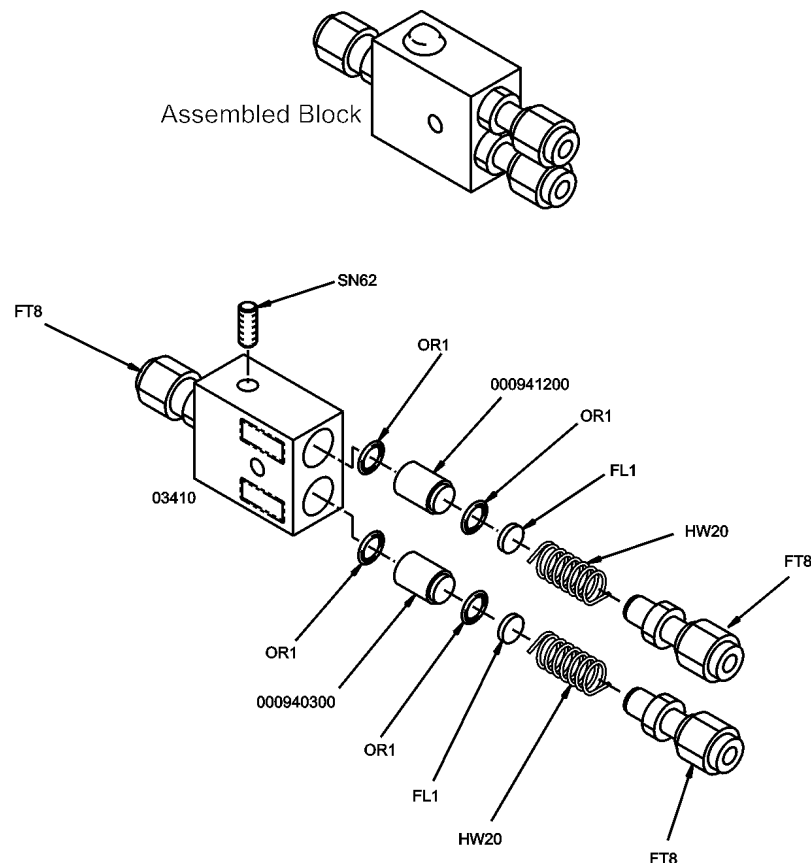

Figure 2-1. Diluter Flow Block Assembly

2.5 THERMOCOUPLE REPLACEMENT

Continuous operation at 1000 °C will eventually degrade the performance of the thermocouple used to sense the temperature of the quartz oven. The following instructions describe how to install a new thermocouple into the Converter Heater Block. This is a replacement thermocouple (KIT000255). The following instructions provide the necessary information to remove the existing thermocouple and replace it with the new one supplied in Kit 255.

You will need the following tools:

- Nutdriver, $\frac{5}{16}$
- Nutdriver, $\frac{11}{32}$
- Diagonal Cutter
- Philips head Screwdriver #2

You will need to obtain the following replacement parts kit from TAPI:

- KIT000255 (AKIT, Retrofit, 501TS, TC Type S RPLCMN)

Once you have the right tools and parts, replace the thermocouple as follows:

1. Ensure power is removed from the 501TS Converter. If the Converter has been operational you will need to wait for 2 hours for the Converter oven to cool before continuing with the replacement of the thermocouple.
2. Remove the cover from the Converter chassis.
3. Unscrew the (4) nuts that secure the front panel to the chassis. They are located just behind the Front Panel along the top.
4. Lower the Front Panel to gain easier access to the end of the quartz tube.
5. Unscrew the (3) nuts that secure the inner cover protecting the Heater Block and quartz tube. Remove this cover.
6. Cut the tie-wrap that secures the thermocouple to the fitting at the end of the quartz tube.
7. Loosen the Teflon fitting at the end of the quartz tube taking care not to put any stress on the tube, and slide the fitting off the tube.
8. Remove the thermocouple.
9. Disconnect the thermocouple wires from the Temperature Controller.

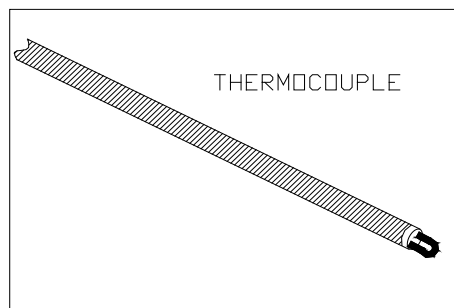

Figure 2-2. Thermocouple

10. In preparation for installing the new thermocouple, look into the end of the Heater Block. You will see that there is an indentation (cavity) in the fat part of the quartz tube. This is where the thermocouple you are installing will reside. Refer to Figure 2-3.

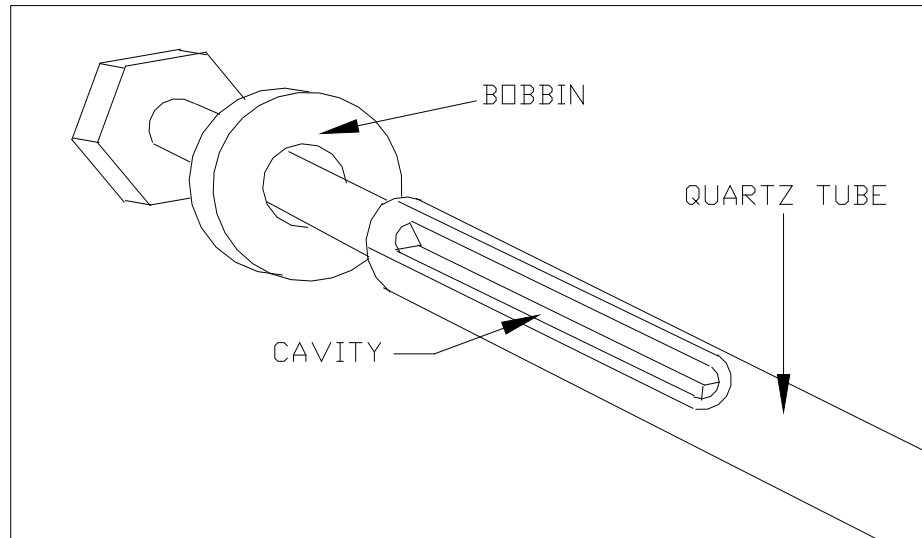

Figure 2-3. Quartz Tube Cavity for Thermocouple

11. The thermocouple should slide into the Heater Block and into the indentation of the quartz.
12. Align the thermocouple with this cavity and carefully push the thermocouple all the way into the cavity until it comes to a stop, which is the end of the cavity of the quartz tube.
13. The thermocouple should now be properly seated in the cavity of the quartz tube. Refer to Figure 2-4

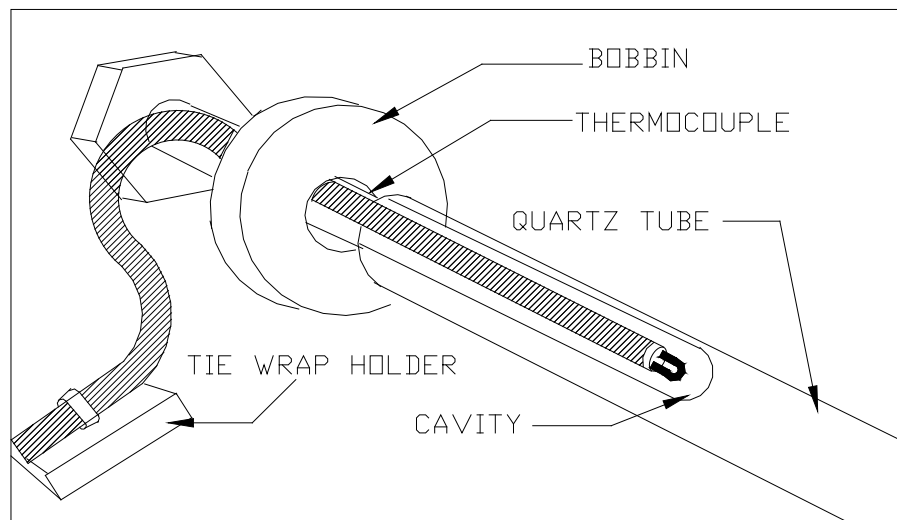

Figure 2-4. Thermocouple Installed

14. Reconnect the Teflon fitting that was removed earlier from the end of the quartz tube. Take care not to put any stress on the quartz tube as the Teflon fitting is tightened.

15. Clean the chassis where the Tie-Wrap Hold-Down will be placed (alcohol is recommended), and place the Tie-Wrap Hold-Down as shown in the Figure 2-5.

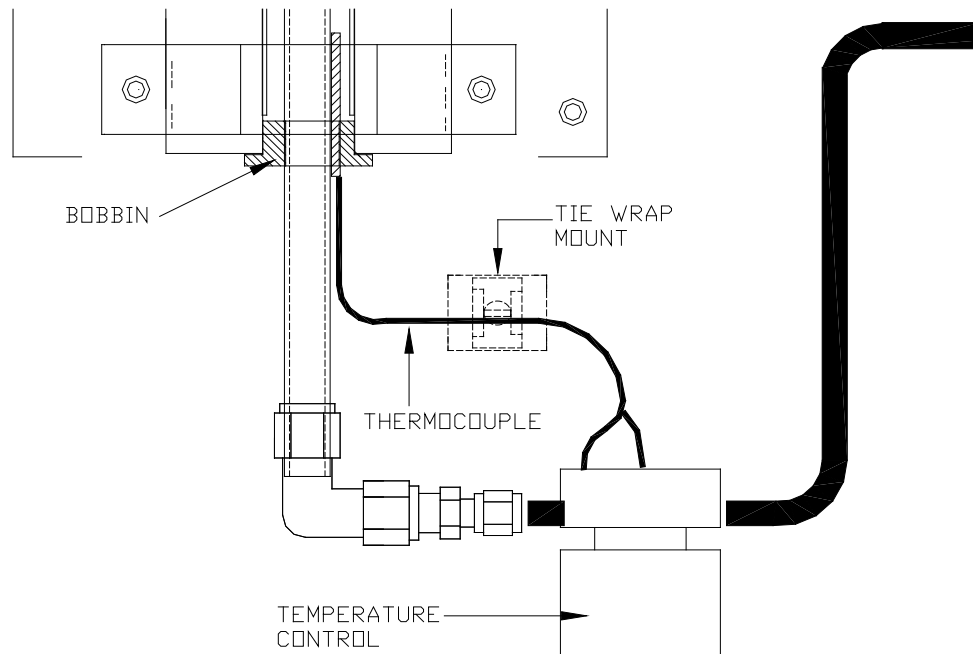

Figure 2-5. Tie-Wrap Hold-Down Location

16. Form the Thermocouple wire so that it rests in the cavity with little movement.
17. Connect the (2) wires of the thermocouple to the Temperature Controller. The Black wire should be connected to Pin 1 and the Red wire should be connected to Pin 2. (If the wires are of any other color, STOP. Get the correct part from TAPI Sales or call Technical Support; see Section 2.6).
18. At this point, all connections have been made, both electrically and pneumatically. A leak check should be performed on the Converter to verify that all connections are leak free. If a leak is detected, the leak should be resolved before continuing.
19. Install the inner cover of the Heater Block and secure with the (3) nuts. Close the Front Panel and secure with the (4) nuts. Install the top cover on the Converter chassis.
20. The Converter is now ready for the application of power. You will be looking for an indication from the temperature controller that it is functioning correctly and driving the heater to the desired “set” temperature. Apply power now.

The converter is now ready for operation.

2.6 TECHNICAL SUPPORT

For Technical Assistance regarding the use and maintenance of this instrument or any other Teledyne API product, contact Teledyne API’s Technical Support Department:

Telephone: 800-324-5190

Email: api-techsupport@teledyne.com

or access any of the service options on our website at <http://www.teledyne-api.com/>

3. INSTRUMENT TEST & CALIBRATION RECORD

For T108 test and calibration information, refer to Table 3-1.

For T108U test and calibration information, refer to Table 3-2.

For test and calibration information with CO₂, refer to Table 3-3.

Table 3-1. Final Test and Calibration Values for T108

TEST Parameters	Observed Value	Units	Acceptable Value
RANGE		PPB	50 - 20,000
STABIL		PPB	0.0 - 2
PRESS		" HG	24 - 35
SAMP FL		CC / MIN	500 - 700 w/CO ₂
PMT		mV	0 - 5000
UV LAMP		mV	3500 - 4000
STR. LGT		PPB	< 60
DRK PMT		MV	< 50
DRK LMP		MV	< 50
SLOPE			1.0 ± 0.3
OFFSET		MV	< 100
HVPS		V	400 - 900 constant
DCPS		MV	2500 +/- 200
RCELL TEMP		°C	50 +/- 1
BOX TEMP		°C	8-50
PMT TEMP		°C	7.9 +/- 1
IZS TEMP		°C	50 +/- .3
Electric Test			
PMT Volts		MV	1000 +/- 200
TS Conc		PPB	500 +/- 100
Optic Test			
PMT Volts		MV	1000 +/- 200
TS Conc		PPB	500 +/- 100

Table 3-2. Test and Calibration Values for T108U

TEST PARAMETERS	OBSERVED VALUE	UNITS	ACCEPTABLE VALUE(S)
RANGE		PPB	5 - 20,000
STAB1		PPB	≤0.05 ppb with zero air
STAB2		PPB	≤0.1 ppb with zero air
PRESS		" HG	ambient ± 2
SAMPLE FL		CC / MIN	650 cm ³ /min ± 10%
PMT		mV	-20 TO 150 mV with zero air
UV LAMP		mV	2000 - 4800
STR LGT		PPB	< 25
DRK PMT		MV	200 - 325
DRK LMP		MV	-50 - 200
SLOPE			1.0 ± 0.3
OFFSET		MV	< 250
HVPS		V	≈ 400 to 900
RCELL TEMP		°C	50 ± 1°
BOX TEMP		°C	ambient + ~ 5
PMT TEMP		°C	7 ± 2
IZS TEMP (option)		°C	50 ± 1
Electric Test			
PMT Volts		MV	1000 +/-200
TS Conc		PPB	500 +/- 100
Optic Test			
PMT Volts		MV	1000 +/- 200
TS Conc		PPB	500 +/- 100

Table 3-3. Test and Calibrations Values w/ CO2 where applicable

Span and Cal		Values	Acceptable Value
Parameter	Observed Value	Units	Nominal Range
TS Span Conc.		PPB	20 - 20,000
TS Slope			1.0 +/- .3
TS Offset		MV	< 100
Noise at Zero (rms)		PPB	< 0.2
Noise at Span (rms)		PPB	< 0.5
PMT at Zero (SO ₂ /CO ₂)		MV	
PMT at Span (SO ₂ /CO ₂)		MV	
Measured Flows			
Parameter	Observed Value	Units	Nominal Range
Sample Flow w/ CO ₂		cc/min	500 - 700
Sample Flow w/Air		cc/min	400 - 600
Sample Press w/CO ₂		“ HG	24 - 27
IZS Purge Flow		cc/min	50 +/- 10
H₂S Conversion Efficiency	Expected = _____	PPB	Actual = _____ PPB
			Efficiency = _____ % (100 ± 2%)
Factory Installed Options		Option Installed	
Power Voltage/Frequency			
Rack Mount, w/ Slides			
Rack Mount, w/ Ears Only			
Internal Zero/Span - IZS			
Permeation Tube (Output Specification)			
4-20 MA Current Loop Output			
External Pump			

PROM Rev #: _____

T108TS S/N: _____

501TS S/N: _____

Date: _____

Technician: _____