

Model 701H High Performance Zero Air System Characterization

1.0 Purpose

The purpose of this study is to characterize the Model 701H high performance zero air system output using the most sensitive instrumentation at our disposal, with the focus on quantifying NAAQS gas phase species (SO₂, NO₂, CO, & O₃) as well as nitric oxide (NO) and volatile organic compounds (VOCs). This was done in two parts: one where the actual air generated by the 701H was scrutinized for any creation or ambient breakthrough of the gases listed, and the other where known elevated levels of the gas pollutants were introduced into the intake of the 701H to assess its ability to scrub such levels of pollution.

2.0 Model 701H Description

The Model 701H is an upgraded version of the Model 701 zero air generator. The 701H utilizes a higher capacity pump, water trap and regenerative dryer which allows for increased drying efficiency and output capacity. The 701H can deliver a sustained output of up to 30 SLPM at 35 psig with a dew point of <-40°C, even while operating in environments with 100% relative humidity. The 701H is also fitted with a dew point sensor that will indicate a warning signal if the output dew should for whatever reason exceed -16°C. The fittings within the 701H are all clean stainless steel in order to reduce the possibility of contamination. Additionally, unlike the model 701, the Model 701H is fitted as standard with a high performance hydrocarbon & CO scrubber, a purafil canister, an activated charcoal canister, and an additional CO scrubber prior to the output of the instrument to eliminate any natural out-gas of CO from the activated carbon.

3.0 Model 701H zero air output characterization

The zero air output of the 701H was compared to a synthetically produced zero air in order to examine if there is any production, or ambient breakthrough, of SO₂, NO₂, CO, O₃, NO, or VOCs. Synthetic zero air was produced by mixing pure N₂ and pure O₂ at 79% and 21% respectively. The N₂ and O₂ flows were controlled with separate mass flow controllers (at a total flow of 5060 cc/min) and were mixed in tubing after combining with a Swagelok "T" union. Excess flow was relieved via a vent line connected to a Swagelok "T" prior to the instruments inlet. Figure 1A shows a diagram of the synthetic zero air sampling setup. Each instrument listed sampled off of the synthetic zero air for several consecutive days (5+) in order to establish a good statistical baseline for "zero" and to examine zero drift (if any) for each instrument.

After sampling the synthetic zero air, each instrument was then subjected to sampling 701H zero air for at least an equal amount of time as the synthetic zero air. Rather than using a single line and the same mass flow controllers to send the 701H zero air to the analyzers, the flow was controlled with a model 700E gas calibrator and sent through a glass sampling manifold. The 701H flow was maintained at 6 SLPM by the M700E calibrator. Figure 1B shows a diagram of the 701H zero air sampling setup. Using this multi-port manifold allowed for more than one analyzer at a time to sample the M701H output.

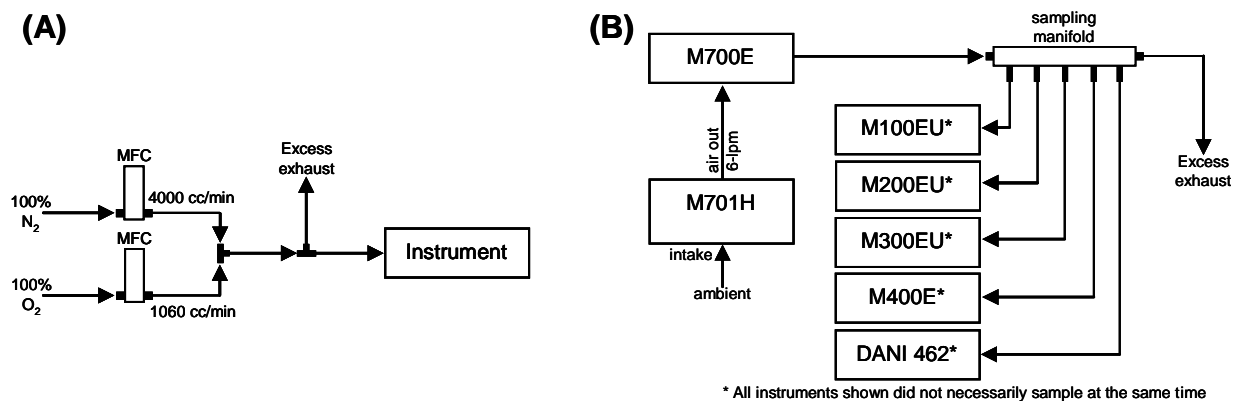

Figure 1. A) Synthetic zero air sampling setup. “Instrument” is used to designate the M100EU, M200EU, M300EU, M400E, and DANI TNMH 462 that all sampled off this setup; B) Diagram of the M701H zero air sampling setup.

3.1 Model 701H pollutant breakthrough / rejection characterization

The second part of this experiment was to introduce known levels of pollutants (SO₂, NO₂, NO, CO, O₃, and VOCs) into the intake of the 701H to assess the 701H’s ability to scrub such levels of pollution. These evaluations were performed one pollutant at a time and usually sampling with just the one instrument capable of measuring the target gas species. In the case where a pollutant has a known interference with another instrument, both the primary measurement instrument for the target gas and the instrument that can detect the analyte gas as an interferent were run together. The levels of the pollutants to be introduced to the 701H were determined by the National Ambient Air Quality Standard (NAAQS) levels for the criteria gas phase pollutants (SO₂, NO₂, and CO) as well as the Occupational Safety and Health Administrations (OSHA) permissible exposure limits (PELs) for each of the criteria pollutants as well as NO and VOCs. Table 1 lists the experimental conditions for each analyzer and analyte gas.

Table 1. M701H pollutant breakthrough / rejection experimental conditions

Target Pollutant	Instrument	Target Pollutant Concentration at Inlet of M701H	NAAQS, AQI, or OSHA PEL Criteria	M701H Output Flow	Sampling Time
SO ₂	TAPI M100EU	30 ppb	NAAQS annual mean primary standard	5 lpm	2.5 hours
		140 ppb	NAAQS 24-hour primary standard	5 lpm	2 hours
		500 ppb	NAAQS 3-hour secondary standard	5 lpm	1 hour
		5 ppm	OSHA PEL	5 lpm	2.5 hours
		10 ppm	2x OSHA PEL	5 lpm	1.7 hours
		10 ppm	2x OSHA PEL	10 lpm	1 hour
NO ₂	TAPI M200EU	53 ppb	NAAQS annual mean primary standard	5 lpm	2.2 hours
		2 ppm	Upper boundary of AQI hazardous category for NO ₂	5 lpm	18.5 hours
		2 ppm	Upper boundary of AQI hazardous category for NO ₂	10 lpm	2 hours
		10 ppm	2x OSHA PEL	5 lpm	2 hours
		10 ppm	2x OSHA PEL	10 lpm	19.6 hours
NO	TAPI M200EU	50 ppm	2x OSHA PEL	5 lpm	2 hours
		50 ppm	2x OSHA PEL	10 lpm	1 hour
CO	TAPI M300EU	35 ppm	NAAQS 1-hour primary standard	5 lpm	2 hours
		50 ppm	OSHA PEL	5 lpm	1.1 hours
		50 ppm	OSHA PEL	10 lpm	2.75 hours
		100 ppm	2x OSHA PEL	5 lpm	2.1 hours
O ₃	TAPI M400E	140 ppb	20ppb above the NAAQS 1-hour primary standard	5 lpm	1.5 hours
		200 ppb	2x OSHA PEL	5 lpm	1.5 hours
VOCs *	GC-MS	20 ppm	2x OSHA 8-hour time weighted average PEL for benzene	10 lpm	11 min grab sample *
		22 ppm	2x OSHA 8-hour time weighted average PEL for benzene	20 lpm	11 min grab sample *
		155 ppm	3x OSHA acceptable 10-min duration maximum for benzene	20 lpm	11 min grab sample *

* VOCs = benzene, toluene, 2-butanone, chloromethane, dichloromethane, dichlorofluoromethane, trichlorofluoromethane

* Sample collected in SUMMA canister and sent to TestAmerica Lab in Los Angeles for GC-MS analysis

In order to deliver the correct concentration of analyte species to the intake of the 701H, a gas mixing/dilution setup was created prior to, and in-line with, the intake of the 701H. The flow of the target pollutant gas was controlled with a precision micrometer controlled needle valve and the flow verified with a Bios DryCal DC2 flow meter. The diluent for blending/diluting the target pollutant gas is provided by a model 701 whose flow is controlled by a needle valve to 25 SLPM and verified using a Cole Parmer 044-41ST flow meter. A diagram of the experimental setup for the pollution breakthrough/rejection tests is provided in Figure 2.

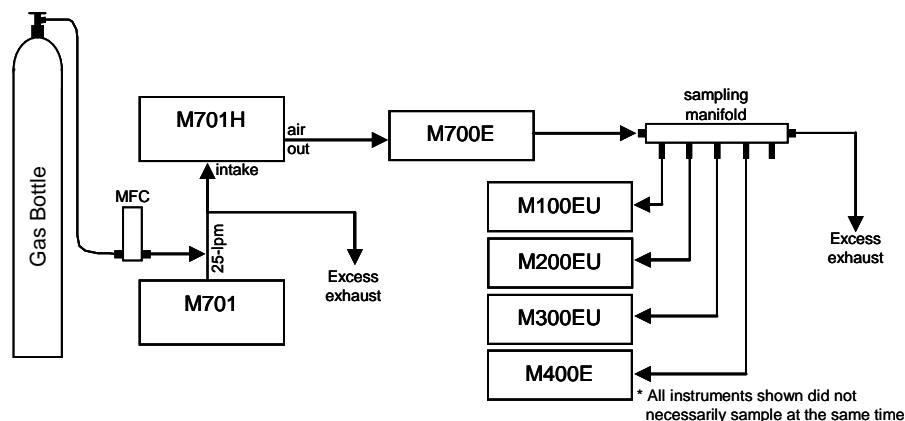

Figure 2. Experimental setup for the pollution breakthrough/rejection tests

A multi-blend bottle of gas containing methane and propane was used for the calibration and for instrument response verification by delivering different concentrations of both gasses after diluting with a model 700E calibrator. For the 701H VOC breakthrough / rejection tests, the inlet of the DANI 462 sampling line was positioned directly in the air intake path of the M701H. The SUMMA canisters used were 6 L volume, both cleaned and evacuated to -30 inHg by Test America Laboratories. Samples were taken for the various conditions by intersecting the output line of the M701H with a stainless steel Swagelok “T” and opening the valve of the SUMMA canister to allow the evacuated canister to pull in its sample. The canister valve was closed after its internal pressure reached -10.5 in-Hg, which took about 11 minutes for each canister. The samples were then sent to Test America Laboratories in Los Angeles, CA. and analyzed via gas chromatography mass spectrometry (GC-MS).

4.1 Model 701H zero air vs. Synthetic zero air

As can be seen from the results shown in Table 2, there is no difference between the measurements taken for model 701H zero air and the synthetically produced zero air for any of the instruments used. These results show that there is no generation of SO₂, NO, NO₂, CO, O₃ or VOCs from the 701H.

Table 2. Model 701H zero air output characterization comparison to synthetic zero air

Target Pollutant	Instrument	Instrument Baseline Noise (RMS)	Average Measurement of Synthetic Zero Air	Average Measurement of M701H Zero Air	M701H Zero Air Output
SO ₂	TAPI M100EU	0.025 ppb	0.00 ppb	0.00 ppb	< 0.025 ppb
NO _x (NO + NO ₂)	TAPI M200EU	0.025 ppb	0.00 ppb	0.00 ppb	< 0.025 ppb
O ₃	TAPI M400E	0.30 ppb	0.00 ppb	0.00 ppb	< 0.30 ppb
CO	TAPI M300EU	10 ppb	0.00 ppb	0.00 ppb	< 10 ppb
VOCs *	GC-MS	0.25 ppb *	0.00 ppb	0.00 ppb	< 0.25 ppb

* VOCs = benzene, toluene, 2-butanone, chloromethane, dichloromethane, dichlorofluoromethane, trichlorofluoromethane

* Lower detectable limit of the GC-MS, rather than the baseline noise

The numbers provided in Table 2 are based on the RMS baseline noise of the instruments used rather than their published lower detectable limits (which are twice the RMS baseline noise). This was done because on sampling zero air, the true zero baseline of each instrument can be thoroughly scrutinized to an extent more sensitive than the RMS noise level reported, and any deflection of the data beyond the noise can be detected. One of the primary reasons the instruments sampled on the synthetic zero air and 701H zero air for such long times (as previously described) was to provide enough data for this level of baseline analysis. The data collected by the GC-MS for the analysis of VOCs is on a much shorter timescale, and only one analysis run per grab sample was conducted. Therefore, there was not enough statistical data per sample to use the baseline noise of the GC-MS as the threshold for analyte detection so the results for the GC-MS analysis are based on the lower detectable limit of the instrument.

4.2 M701H pollutant rejection performance

As previously mentioned, the levels of the pollutants to be introduced to the 701H for rejection performance testing were determined by the NAAQS levels for the criteria gas phase pollutants (SO₂, NO₂, and CO) as well as the OSHA PELs for each of the criteria pollutants as well as NO and VOCs. Additionally, each target gas (per concentration) was introduced to the 701H intake for at least 1 – 2 hours while the output

Table 3. M701H pollutant rejection performance

Target Pollutant	Instrument	Target Pollutant Concentration at Inlet of M701H	M701H Output Flow	Average Measurement of M701H Output	M701H Target Pollutant Rejection
SO ₂	TAPI M100EU	30 ppb	5 lpm	0.00 ppb	100%
		140 ppb	5 lpm	0.00 ppb	100%
		500 ppb	5 lpm	0.00 ppb	100%
		5 ppm	5 lpm	0.00 ppb	100%
		10 ppm	5 lpm	0.00 ppb	100%
		10 ppm	10 lpm	0.00 ppb	100%
NO ₂	TAPI M200EU	53 ppb	5 lpm	0.00 ppb	100%
		2 ppm	5 lpm	0.00 ppb	100%
		2 ppm	10 lpm	0.00 ppb	100%
		10 ppm	5 lpm	0.00 ppb	100%
		10 ppm	10 lpm	0.00 ppb	100%
NO	TAPI M200EU	50 ppm	5 lpm	0.00 ppb	100%
		50 ppm	10 lpm	0.00 ppb	100%
CO	TAPI M300EU	35 ppm	5 lpm	0.00 ppb	100%
		50 ppm	5 lpm	0.00 ppb	100%
		50 ppm	10 lpm	0.00 ppb	100%
		100 ppm	5 lpm	0.00 ppb	100%
O ₃	TAPI M400E	140 ppb	5 lpm	0.00 ppb	100%
		200 ppb	5 lpm	0.00 ppb	100%
VOCs *	GC-MS	20 ppm	10 lpm	0.00 ppb	100%
		22 ppm	20 lpm	0.00 ppb	100%
		155 ppm	20 lpm	0.00 ppb**	100%

* VOCs = benzene, toluene, 2-butanone, chloromethane, dichloromethane, dichlorofluoromethane, trichlorofluoromethane

** Analyte concentrations detected at a level below the reliable reporting limit for the instrumentation used

flow was sampled by the specified instrument in Tables 1 and 3. As Table 3 shows there is no breakthrough of SO₂, NO, NO₂, CO, O₃ even at levels as high as double the OSHA permissible exposure limit (PEL).

5.0 Conclusion

The results obtained from these tests shows that the model 701H High Performance Zero Air System does not produce any of the target pollutant species within the detectable limits of the instrumentation used. Additionally, under conditions where the 701H intake takes in air containing elevated levels of the target pollutants, there is no breakthrough of such species that can be detected by the instrumentation used. It is important to note that the analytical instruments used for analyzing the 701H output are among the most sensitive techniques available for the target pollutants specified in this experiment, which is further verification that the 701H produces very clean zero air, even under extreme pollution conditions.