



TELEDYNE INSTRUMENTS
Advanced Pollution Instrumentation
A Teledyne Technologies Company

MODEL **320EU**

Ultra Sensitive Gas Filter Correlation N₂O Analyzer



- ▶▶ **Standard two year warranty**
- ▶▶ **Ranges, 0-200 ppb to 0-200 ppm, user selectable**
- ▶▶ **Gas Filter Wheel for N₂O specific measurement**
- ▶▶ **GFC wheel guaranteed for 5 years**
- ▶▶ **Multi-tasking software allows viewing of test variables during operation**
- ▶▶ **Continuous self checking with alarms**
- ▶▶ **Bi-directional RS-232 for remote operation**
- ▶▶ **Digital status outputs indicate instrument operating condition**
- ▶▶ **Adaptive signal filtering optimizes response time**
- ▶▶ **No mirrors to clean or adjust**
- ▶▶ **Optional Calibration Span Valve**

The Model 320EU measures trace levels of Nitrous Oxide with excellent accuracy and stability due to the Gas Filter Correlation principle employed. The sample concentration is determined by measuring how much infrared light the gas absorbs as it flows through a multi-pass sample cell. The light first passes through a filter wheel that contains an inert gas in one chamber and a reference concentration of N₂O in a second chamber.

After passing through the sample cell the light is detected by an optically-filtered, dual-stage cooled PbSe detector. As the filter wheel revolves the energy loss through the sample cell is compared with the span reference signal provided by the gas filter to produce a signal proportional to sample concentration, with little effect from interfering gases within the sample. This design produces excellent zero and span stability, a high signal-to-noise ratio, high sensitivity and low interferences.

Multi-tasking software gives real time indication of numerous operating parameters and provides automatic alarms if diagnostic limits are exceeded. Built-in data acquisition and internal memory allows logging multiple parameters including average and instantaneous values, calibration data and operating parameters. Stored data can be retrieved via the RS-232 port, Ethernet connection, or from the front panel. The Model 320EU features rugged construction and is designed to perform with a minimum of attention. In the event maintenance is required, modular construction makes service a simple operation.

FREE Customer Support by telephone and email for the life of the instrument



MODEL 320EU

Ultra Sensitive Gas Filter Correlation N₂O Analyzer

Specifications

Ranges:	0-200 ppb to 0-200 ppm full scale, user selectable	Dimensions (HxWxD):	7" (178 mm) x 17" (432 mm) x 23.5" (597 mm)
Units:	Dual ranges and auto ranging supported ppm, mg/m ³	Weight:	40 lbs (18.0 kg)
Zero Noise:	< 5 ppb (RMS)	Power:	100V - 120V, 220V - 240V, 50/60 Hz, 250W
Span Noise:	< 0.5% of reading (RMS)	Analog Outputs:	10V, 5V, 1V, 100mV, selectable
Lower Detectable Limit (LDL):	< 10 ppb (RMS)	Recorder Offset:	±10%
Zero Drift:	< 10 ppb/24 hours, < 20 ppb/7 days	Serial Outputs:	Serial Port 1: RS-232, DB-9M Serial Port 2: standard RS-232 or optional RS-485, DB-9F, Ethernet
Span Drift:	< 0.5%/24 hours, < 1% of reading/7 days	Status (Digital)	8 outputs, 6 inputs (opto-isolated), 4 alarm outputs (optional)
Rise and Fall Time:	< 60 seconds to 95%	Current Output:	Optional 4-20mA
Linearity:	1% of range	Approvals:	CE
Precision:	0.5% of reading	NOTE:	The values expressed above are in accordance with EPA definitions. All error specifications are based on constant conditions.
Sample Flow Rate:	800 cc/min ± 10%		
Operating Temperature Range:	5 - 40°C		

Schematic

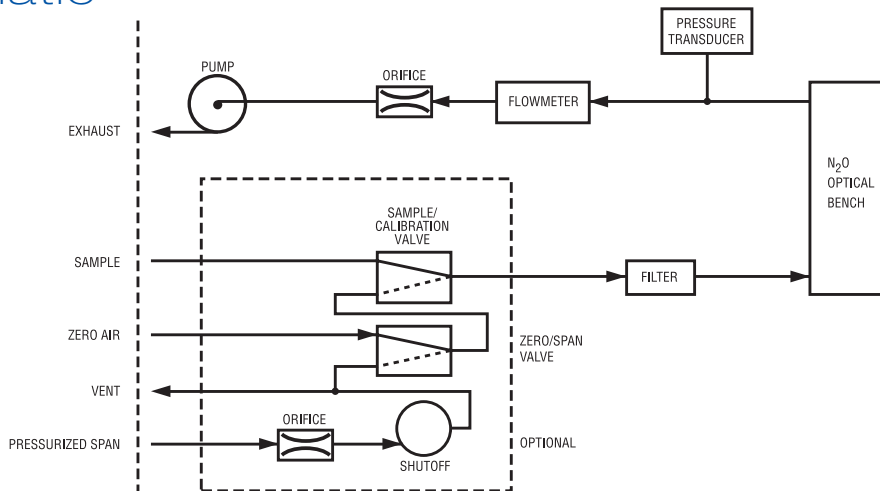

How to Order

Model 320EU Ultra Sensitive Gas Filter Correlation N₂O Analyzer includes:

- Standard two year warranty
- Internal pump
- Auto ranging and dual ranges
- 47mm diameter particulate filter
- 8 isolated digital status outputs
- 4 opto insulated alarm outputs optional

Specify input AC voltage & frequency:

- 100V - 115V 50Hz
 220V - 240V 60Hz

Specify output DC voltage:

- 10V 5V 1V 100mV

Additional Options:

- Rack mount brackets (19") with chassis slides
 Rack mount brackets only
 4-20mA outputs (specify up to three channels)
 Multi-drop RS-232 connection
 Ethernet (replaces one serial port)
 Concentration alarms

Calibration Valves:

- Stainless steel valves for selection of customer-supplied zero and span gas

Accessories:

- RS-232 Cable
 Expendables Kit
 Spare Parts Kit

Specifications subject to change without notice. Printed documents are uncontrolled. SAL000015 B (DCN 5263) M320EU/01/05/09.



TELEDYNE INSTRUMENTS
Advanced Pollution Instrumentation

A Teledyne Technologies Company

9480 Carroll Park Drive San Diego, CA 92121-5201

Ph. 858-657-9800 Fax 858-657-9816

Email api-sales@teledyne.com

For more information about the Teledyne API family of monitoring instrumentation products, call us or visit our website at

www.teledyne-api.com

