



**TELEDYNE**  
ADVANCED POLLUTION INSTRUMENTATION  
A Teledyne Technologies Company

# ***OPERATION MANUAL***

## ***MODEL 465L OZONE MONITOR***

Teledyne Advanced Pollution Instrumentation (T-API)  
9480 Carroll Park Road  
San Diego, CA 92121-5201

Phone: 800-324-5190 (toll free in North America)  
858-657-9800 (direct)

FAX: 858-657-9816

EMAIL: [api-sales@teledyne.com](mailto:api-sales@teledyne.com)

WEB SITE: <http://www.teledyne-api.com/>

PRINT: 28 October 2009  
© 2007-2009 T-API

Part Number 05509  
Revision D (DCN 5522)  
G October 2009



# ABOUT THIS MANUAL

This manual is comprised of multiple documents as listed below.

<b>Part Number</b>	<b>Name/Description</b>
05590	Title (contains Cover and front matter pages)
05511	Text (contains the main body of this manual)
05919	Rack Mount Spare Parts List (integrated into this manual as Section 12.1)
05910	NEMA Spare Parts List (integrated into this manual as Section 12.2)





## **NOTE**


We recommend that this manual be read in its entirety before any attempt is made to operate the instrument.

## SAFETY MESSAGES

Your safety and the safety of others is very important. We have provided many important safety messages in this manual. Please read these messages carefully.

A safety message alerts you to potential hazards that could hurt you or others. Each safety message is associated with a safety alert symbol. These symbols are found in the manual and inside the instrument. The definition of these symbols is described below:

	<u>GENERAL WARNING/CAUTION</u> : Refer to the instructions for details on the specific danger.
	<u>CAUTION</u> : Hot Surface Warning
	<u>WARNING</u> : Electrical Shock Hazard
	<u>Technician Symbol</u> : All operations marked with this symbol are to be performed by qualified maintenance personnel only.

	<p style="text-align: center;"><b>CAUTION</b></p> <p>The analyzer should only be used for the purpose and in the manner described in this manual. If you use the analyzer in a manner other than that for which it was intended, unpredictable behavior could ensue with possible hazardous consequences.</p>
-------------------------------------------------------------------------------------	---------------------------------------------------------------------------------------------------------------------------------------------------------------------------------------------------------------------------------------------------------------------------------------------------------------

# TABLE OF CONTENTS

---

<b>ABOUT THIS MANUAL</b> .....	<b>i</b>
<b>SAFETY MESSAGES</b> .....	<b>ii</b>
<b>1. INTRODUCTION</b> .....	<b>7</b>
1.1. PREFACE .....	7
<b>2. SPECIFICATIONS, AGENCY APPROVALS, AND WARRANTY</b> .....	<b>9</b>
2.1. SPECIFICATIONS .....	9
2.2. AGENCY APPROVALS .....	10
2.3. WARRANTY POLICY.....	11
<b>3. PRINCIPLE OF OPERATION</b> .....	<b>12</b>
<b>4. GETTING STARTED</b> .....	<b>14</b>
4.1. PNEUMATIC CONNECTIONS.....	16
4.1.1. <i>Sample Gas Connection</i> .....	17
4.1.2. <i>Exhaust Connection</i> .....	21
4.2. ELECTRICAL I/O CONNECTIONS .....	22
4.2.1. <i>Location of I/O Connectors in the NEMA Configuration</i> .....	22
4.2.2. <i>Analog Output</i> .....	22
4.2.3. <i>Status Outputs</i> .....	22
4.2.4. <i>Hi-Current Relay Outputs</i> .....	24
4.2.5. <i>Multi-Stream Relay Outputs (Optional)</i> .....	25
4.2.6. <i>Digital Serial Interfaces</i> .....	26
<b>5. FREQUENTLY ASKED QUESTIONS</b> .....	<b>27</b>
<b>6. OPTIONS</b> .....	<b>28</b>
6.1. STREAM SELECTOR (3 OR 6 STREAM) .....	28
6.2. DISPOSABLE SAMPLE INLET FILTERS .....	28
6.3. RACK MOUNT SLIDES.....	28
6.4. ELECTRONIC FLOWMETER .....	28
6.5. SAMPLE CONDITIONER .....	28
6.6. PERMEATION GAS DRYER .....	28
<b>7. OPERATION</b> .....	<b>30</b>
7.1. FRONT PANEL OVERVIEW.....	30
7.1.1. <i>Ozone Concentration Display</i> .....	30
7.1.2. <i>Menu Navigation Keypad</i> .....	30
7.1.3. <i>Stream Selector Status/Control (Optional)</i> .....	31
7.1.4. <i>Concentration Alarm Status/Reset</i> .....	31
7.1.5. <i>Status LEDs</i> .....	32
7.2. FRONT PANEL MENUS.....	32
7.2.1. <i>Menu Navigation Basics</i> .....	32

7.2.2. <i>Editing Numeric Values</i> .....	33
7.2.3. <i>DIAG Menu</i> .....	36
7.2.4. <i>VIEW Menu</i> .....	42
7.2.5. <i>CONFIG Menu</i> .....	42
7.2.6. <i>SETUP-VARS Menu</i> .....	43
7.2.7. <i>SETUP-STREAM Menu</i> .....	44
7.3. MULTI-STREAM OPERATION.....	45
<b>8. DIGITAL COMMUNICATIONS</b> .....	<b>46</b>
8.1. DIGITAL COMMUNICATIONS OVERVIEW .....	46
8.2. CHANGING COM PORT HARDWARE CONFIGURATION.....	46
8.3. RS-232 CONFIGURATION .....	48
8.4. RS-485 CONFIGURATION .....	49
8.5. ETHERNET CONFIGURATION .....	50
8.5.1. <i>Hardware Setup for Configuring the Ethernet Module</i> .....	50
8.5.2. <i>Verifying Network Hardware Connection</i> .....	50
8.5.3. <i>Determining a Dynamically Assigned IP Address (DHCP Mode)</i> .....	51
8.5.4. <i>Manually Assigning a Static IP Address</i> .....	51
8.6. MODBUS REGISTER MAPS .....	53
8.6.1. <i>MODBUS Commands Supported</i> .....	53
8.6.2. <i>Notes on MODBUS registers</i> .....	53
8.6.3. <i>Real-Time Concentration and Status Registers (Read Only)</i> .....	54
8.6.4. <i>Instrument Setup and Configuration Registers (Read / Write)</i> .....	55
<b>9. MAINTENANCE AND ADJUSTMENTS</b> .....	<b>58</b>
9.1. MAINTENANCE SCHEDULE .....	58
9.2. INSTRUMENT LAYOUT .....	59
9.3. REPLACING INTERNAL PARTICULATE FILTER.....	61
9.4. UV LAMP ADJUSTMENT .....	61
9.5. UV LAMP REPLACEMENT .....	62
9.6. SAMPLE PUMP REPLACEMENT .....	63
9.7. SENSOR VALVE REPLACEMENT .....	64
9.8. WATER DROP-OUT FILTER (OPTION) MAINTENANCE.....	65
9.9. CONFIGURING THE ANALOG OUTPUT .....	65
9.10. CLEANING EXTERIOR SURFACES OF THE M465L .....	66
<b>10. TROUBLESHOOTING</b> .....	<b>68</b>
10.1. REFERENCE DRAWINGS .....	68
10.1.1. <i>Pneumatic Diagram</i> .....	68
10.1.2. <i>Interconnect Diagram</i> .....	69
10.2. TROUBLESHOOTING USING FRONT PANEL STATUS LED'S OR STATUS OUTPUTS .....	70
10.2.1. <i>Sensor OK</i> .....	71
10.2.2. <i>Invalid Reading</i> .....	71
10.2.3. <i>Check Lamp</i> .....	71
10.2.4. <i>Pneumatic Error</i> .....	71

<b>11. CALIBRATION</b> .....	<b>74</b>
11.1. FACTORY CALIBRATION .....	74
11.2. ZERO CALIBRATION.....	74
<b>12. SPARE PARTS</b> .....	<b>76</b>
12.1. M465L RACK MOUNT SPARE PARTS LIST.....	76
12.2. M465L NEMA SPARE PARTS LIST .....	77

## FIGURES

Figure 4-1: Pneumatic Connections, Rack Mount Configuration .....	16
Figure 4-2: Pneumatic Connections, NEMA Configuration, Single Stream .....	16
Figure 4-3: Pneumatic Connections, NEMA Configuration, Multi-Stream .....	17
Figure 4-4. M465L Pneumatic Diagram with Sample Conditioner and Permeation Gas Dryer Options (in single-stream configuration).....	19
Figure 4-6: Rear Panel Electrical I/O Connections .....	21
Figure 4-7: NEMA Electrical I/O Connections .....	21
Figure 4-8: Status Output Schematic .....	23
Figure 7-1: Front Panel Display.....	30
Figure 7-2: Front Panel Menu Diagram (Page 1) .....	34
Figure 7-3: Front Panel Menu Diagram (Page 2) .....	35
Figure 7-4: Span Cal Menu .....	40
Figure 7-5: Flow Cal Menu .....	41
Figure 8-1: Com Configuration Jumper Settings (SW2).....	47
Figure 9-1: Instrument Layout, Rack Mount Configuration .....	59
Figure 9-2: Instrument Layout, NEMA Configuration.....	60
Figure 9-3: Sensor Detail .....	64
Figure 9-4: Mainboard – Analog Output Configuration .....	66
Figure 10-1: Pneumatic Diagram, 3 Stream Configuration.....	68
Figure 10-2: Interconnect Diagram.....	69

## TABLES

Table 4-1: Status Output Definitions.....	23
Table 4-2: Relay Functions for Single Stream Config.....	24
Table 4-3: Relay Functions for Multi-Stream Configs.....	24
Table 4-4: Multi-Stream Relays.....	25
Table 7-1: Alarm LED's.....	31
Table 7-2: Status LED's.....	32
Table 7-3: Analog Step Test Values.....	36
Table 7-4: Signal I/O List.....	37
Table 7-5: VIEW Menu Parameters.....	42
Table 7-6: CONFIG Menu Parameters.....	42
Table 7-7: VARS List.....	43
Table 7-8: STREAM Properties.....	44
Table 8-1: RS-232 Connector Details.....	48
Table 8-2: RS-232 Port Setup.....	48
Table 8-3: RS-485 Connector Details.....	49
Table 8-4: RS-485 Port Setup.....	49
Table 8-5: Ethernet LED Definitions.....	50
Table 8-6: Supported MODBUS Commands.....	53
Table 9-1: Maintenance Schedule.....	58
Table 10-1: Status LED/Output Definitions.....	70

# 1. INTRODUCTION

---

## 1.1. Preface

The Teledyne API Model 465L is a UV photometric ozone monitor designed and manufactured for single/multi-channel industrial hygiene ozone analysis. It is a very stable analyzer, ideal for critical low-level PPM safety and process applications. Whether you have selected the rack mount or NEMA 4X wall mount unit, the M465L is designed to be highly reliable and simple to operate with easy setup and user-friendly menu driven software that can also be set and monitored remotely.

As the M465L was designed for stability, reliability and simplicity, it includes built-in tests and diagnostics to facilitate maximum uptime. In addition to a full one year warranty (see Section 1.2), Teledyne API is pleased to provide you with any support required so that you may utilize our equipment to the fullest extent. Our full time customer service department is available to answer your questions.

This page intentionally left blank.

## 2. SPECIFICATIONS, AGENCY APPROVALS, AND WARRANTY

---

### 2.1. Specifications

Ranges	User selectable to any full scale range from: 1 PPM to 500 PPM 1000 PPB to 10,000 PPB 2000 $\mu\text{g}/\text{m}^3$ to 10,000 $\mu\text{g}/\text{m}^3$ 100 PPHM to 10,000 PPHM (optional configuration)
Measurement Units	PPM, PPB, $\mu\text{g}/\text{m}^3$ , PPHM (optional configuration)
Zero Noise	< .0015 PPM (rms)
Span Noise	< .5% of reading (rms) (above 0.1 PPM)
Lower Detectable Limit	< .003 PPM (rms)
Accuracy	+/- 1% of full scale range
Response Time (95%)	<30 sec (<60 sec with the Sample Conditioner option)
Sample Flow Rate	0.8 L/min
Temperature Range	5-45° C
Humidity Range	10-90% RH, Non-Condensing
Dimensions (H x W x D)	5.22" x 19.0" x 15.3" (133 mm x 483 mm x 388 mm) – Rack Mount Version 16.01" x 15.6" x 6.90" (407mm x 396mm x 175mm) – NEMA 4X Version
Weight	12.6 lb. (5.73 kg) - Rack Mount Version 15.2 lb. (6.91 kg) – NEMA 4X Version
Power	100-240 V~, 50/60 Hz, 74W max
Environmental Conditions	Installation Category (Overvoltage Category) II Pollution Degree 2
Maximum Operating Altitude	2000 meters

Analog Output, Voltage Mode	0 - 5V
Isolated Analog Output, 4-20mA Mode	Maximum voltage between outputs and ground 60V peak
System OK Status Relay	SPDT (Form C) Dry Contact, 250 VAC, 5A
Global Alarm Relays	SPDT (Form C) Dry Contact, 250 VAC, 5A (x2, HI and HI-HI)
Instrument Status Outputs	6 - SPST Dry Contact, 50VDC, 250mA Resistive Load

**Multi-Stream Specifications:**

Minimum Stream Duration (Cycle Time)	1.0 min
Stream Alarm Relays (HI and HI-HI)	SPST Dry Contact, 50VDC, 250mA Resistive Load (2 per stream)
Stream ID Relays	SPST Dry Contact, 50VDC, 250mA Resistive Load (1 per stream)

## 2.2. Agency Approvals

CE, SEMI S2 (Rack mount version only)

## 2.3. Warranty Policy

ADVANCED POLLUTION INSTRUMENTATION DIVISION (T-API) 02024B

Prior to shipment, Teledyne API equipment is thoroughly inspected and tested. Should equipment failure occur, Teledyne API assures its customers that prompt service and support will be available.

### COVERAGE

After the warranty period and throughout the equipment lifetime, Teledyne API stands ready to provide on-site or in-plant service at reasonable rates similar to those of other manufacturers in the industry. All maintenance and the first level of field troubleshooting are to be performed by the customer.

### NON-TELEDYNE API MANUFACTURED EQUIPMENT

Equipment provided but not manufactured by Teledyne API is warranted and will be repaired to the extent and according to the current terms and conditions of the respective equipment manufacturer's warranty.

### GENERAL

Teledyne API warrants each Product manufactured by Teledyne API to be free from defects in material and workmanship under normal use and service for a period of one year from the date of delivery. All replacement parts and repairs are warranted for 90 days after the purchase.

If a Product fails to conform to its specifications within the warranty period, Teledyne API shall correct such defect by, in Teledyne API's discretion, repairing or replacing such defective Product or refunding the purchase price of such Product.

The warranties set forth in this section shall be of no force or effect with respect to any Product:

(i) that has been altered or subjected to misuse, negligence or accident, or (ii) that has been used in any manner other than in accordance with the instruction provided by Teledyne API or (iii) not properly maintained.

THE WARRANTIES SET FORTH IN THIS SECTION AND THE REMEDIES THEREFORE ARE EXCLUSIVE AND IN LIEU OF ANY IMPLIED WARRANTIES OF MERCHANTABILITY, FITNESS FOR PARTICULAR PURPOSE OR OTHER WARRANTY OF QUALITY, WHETHER EXPRESSED OR IMPLIED. THE REMEDIES SET FORTH IN THIS SECTION ARE THE EXCLUSIVE REMEDIES FOR BREACH OF ANY WARRANTY CONTAINED HEREIN. TELEDYNE API SHALL NOT BE LIABLE FOR ANY INCIDENTAL OR CONSEQUENTIAL DAMAGES ARISING OUT OF OR RELATED TO THIS AGREEMENT OF TELEDYNE API'S PERFORMANCE HEREUNDER, WHETHER FOR BREACH OF WARRANTY OR OTHERWISE.

### TERMS AND CONDITIONS

*All units or components returned to Teledyne API should be properly packed for handling and returned freight prepaid to the nearest designated Service Center. After the repair, the equipment will be returned, freight prepaid.*

### 3. PRINCIPLE OF OPERATION

---

The detection of ozone molecules is based on absorption of 254 nm UV light due to an internal electronic resonance of the O<sub>3</sub> molecule. The Model 465 uses a mercury lamp constructed so that a large majority of the light emitted is at the 254nm wavelength. Light from the lamp shines down a hollow quartz tube that is alternately filled with sample gas, then filled with gas scrubbed to remove ozone. The ratio of the intensity of light passing through the scrubbed gas to that of the sample forms a ratio I/I<sub>0</sub>. This ratio forms the basis for the calculation of the ozone concentration.

The Beer-Lambert equation, shown below, calculates the concentration of ozone from the ratio of light intensities.

$$C_{O_3} = -\frac{10^9}{\alpha \times \ell} \times \frac{T}{273^\circ \text{K}} \times \frac{29.92 \text{ inHg}}{P} \times \ln \frac{I}{I_0}$$

Where:

I = Intensity of light passed through the sample

I<sub>0</sub> = Intensity of light through sample free of ozone

α = absorption coefficient

ℓ = path length

C<sub>O<sub>3</sub></sub> = concentration of ozone in ppb

T = sample temperature in degrees Kelvin

P = pressure in inches of mercury

As can be seen the concentration of ozone depends on more than the intensity ratio. Temperature and pressure influence the density of the sample. The density changes the number of ozone molecules in the absorption tube which impacts the amount of light removed from the light beam. These effects are addressed by directly measuring temperature and pressure and including their actual values in the calculation. The absorption coefficient is a number that reflects the inherent ability of ozone to absorb 254 nm light. Most current measurements place this value at 308 cm<sup>-1</sup> atm<sup>-1</sup> at STP. The value of this number reflects the fact that ozone is a very efficient absorber of UV radiation which is why stratospheric ozone protects the life forms lower in the atmosphere from the harmful effects from solar UV radiation. Lastly, the absorption path length determines how many molecules are present in the column of gas in the absorption tube.

The intensity of light is converted into a voltage by a high resolution A/D (analog-to-digital) converter. The digitized signal and other variables are used by the CPU to compute the concentration using the above formula.

About every 2.5 seconds the M465 completes a measurement cycle consisting of a 1 second wait period for the sample tube to flush, followed by a 150 ms measurement of the UV light intensity to obtain I. The sample valve is switched to admit scrubbed sample gas for 1 second, followed by a 150 ms measurement of the UV light intensity to obtain I<sub>0</sub>. Measurement of the I<sub>0</sub> every 2.5 seconds eliminates instrument drift due to changing intensity of the lamp caused by aging and dirt.

## 4. GETTING STARTED

---

The Model 465 is shipped with the following standard equipment:

- Power cord (Rack mount version only)
- Instruction manual.

Upon receiving the Model 465 please do the following:

1. Verify no apparent shipping damage. (If damage has occurred please advise shipper first, then Teledyne API.)
2. When installing the Model 465, allow a minimum of 4 inches of clearance at the back of the instrument (rack mount only) and 1 inch of clearance on each side for proper ventilation.
3. Connect sample inlet line(s) to the sample port on rear panel or bottom panel of instrument.

### CAUTION

Connect the exhaust fitting on the rear panel (See Figure 4-1) to a suitable vent outside the monitor area.



### NOTE

See Figure 4-1 for rear panel pneumatic connections. Sample tubing made from an inert material such as Teflon should be used to minimize sample degradation.

4. Connect the power cord to an appropriate power outlet (see the serial number tag for correct voltage and frequency). For the NEMA configuration, the electrical connection must be hard-wired to the 3-pin connector on the mainboard labeled J23 (See Figure 9-2 for details.) Observe local electrical codes when connecting power to the monitor.

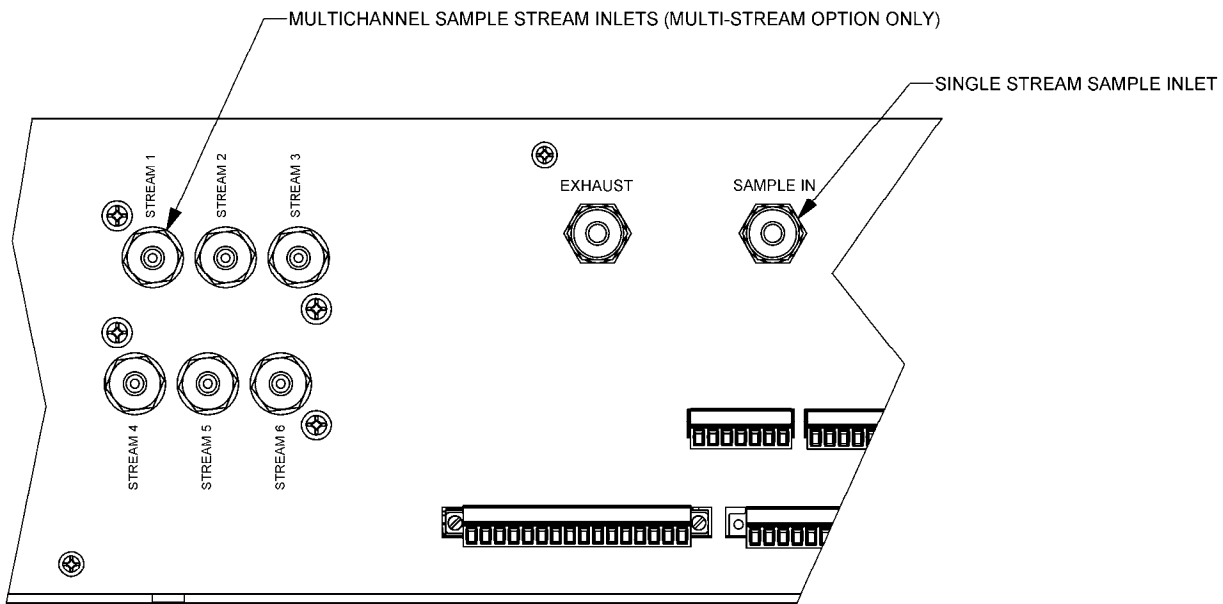
### CAUTION

Verify that the instrument is set up for proper line voltage and frequency.

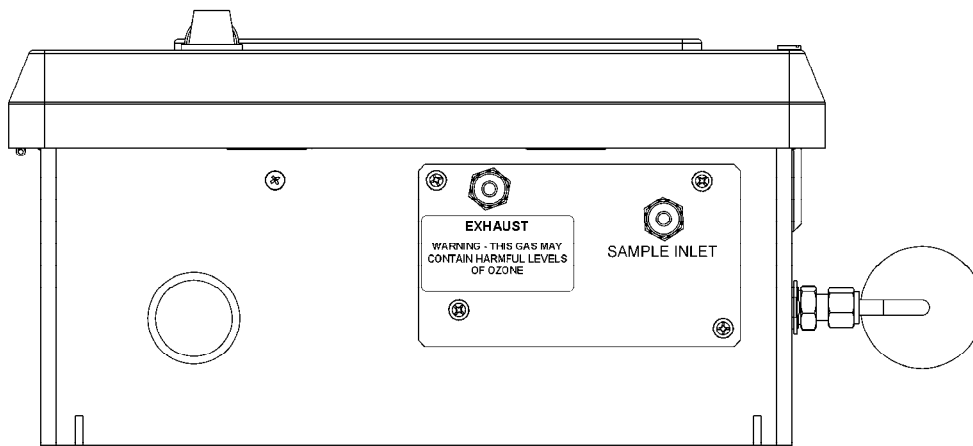
5. Turn on the M465L by switching the switch on the left side of the rear panel, or applying power to the monitor (NEMA configuration.) The front panel display should light with a sequence of messages, including the instrument serial number and software revision.

6. When the instrument first powers up, the display will show 'xxxx', indicating that the instrument is in start-up mode, waiting for the UV detector readings to stabilize.
7. After the start-up period, the instrument will begin displaying the ozone concentration and the optional stream selector will begin operating, if installed.

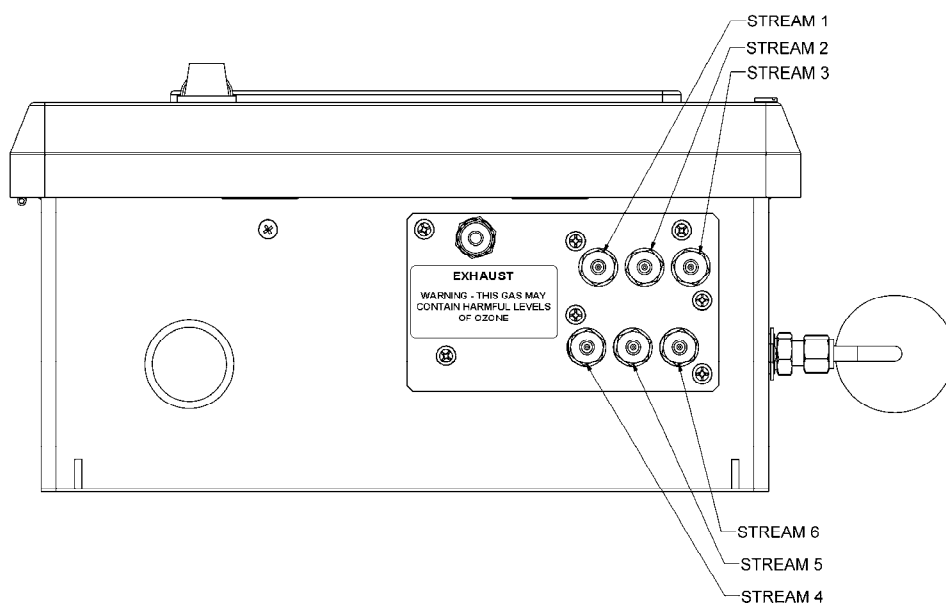
## 4.1. Pneumatic Connections



**Figure 4-1: Pneumatic Connections, Rack Mount Configuration**



**Figure 4-2: Pneumatic Connections, NEMA Configuration, Single Stream**



**Figure 4-3: Pneumatic Connections, NEMA Configuration, Multi-Stream**

### 4.1.1. Sample Gas Connection

Sample gas connections are made to the 1/4" tube fittings on the rear panel. For single stream monitors, use the fitting labeled "Sample Inlet." For multi-stream monitors, the sample tubing is connected to the fittings labeled Stream 1, Stream 2, etc (See Figure 4-1, Figure 4-2, Figure 4-3)

1/4" O.D. FEP (Teflon™) tubing is recommended to connect the sample source to the monitor. Any fittings used in the sample lines should be constructed of stainless steel or Teflon™.

Teledyne API recommends that the length of tubing connecting the sample points to the monitor should be kept to 50 feet or less.

#### **NOTE**

For the sampling lines, use only 1/4" O.D. FEP tubing. For best analytical performance, the tubing should be pre-conditioned to ozone prior to installation to minimize ozone loss in the sampling lines. Pre-conditioned 1/4" FEP tubing is available from Teledyne API (Part number 02639)

#### 4.1.1.1. Sample Filtration

The most important factor in maintaining an accurate and stable monitoring system for ozone is the cleanliness of entire pneumatic system leading up to (and including) the sensor assembly inside the instrument. Provision must be made for keeping dust and other particulate matter out of the monitor and upstream sample delivery tubing. The monitor is equipped with an internal particulate filter down-stream of the selector manifold.

In addition, it is recommended that inlet filters be installed at the inlet of each sample line. These filters should be constructed of PTFE or other inert material to avoid degradation of the ozone concentration. Appropriate disposable inlet filters can be purchased from T-API. See the Spare Parts list in Appendix A of this manual for ordering information.

#### 4.1.1.2. Sample System Design in Humid Environments

Care must be taken in the design of the sampling system to ensure that water vapor does not condense in the sampling lines or in the instrument itself. The sample lines should be routed to avoid large temperature gradients along the lines. If sample is brought in from a hot, humid area into a much cooler area, then low power heating tape should be wrapped around the lines to keep the temperature of the sample lines up and avoid condensation. The lines should also not have loops or low points where water could collect.

For applications that require sampling of very humid gas, a Sample Conditioner and/or a Permeation Gas Dryer may be required to lower sample gas humidity. A pneumatic block diagram with the locations of these M465L options is shown in Figure 4-4, followed by a description of each. Please contact the Teledyne API Sales Department for additional information.

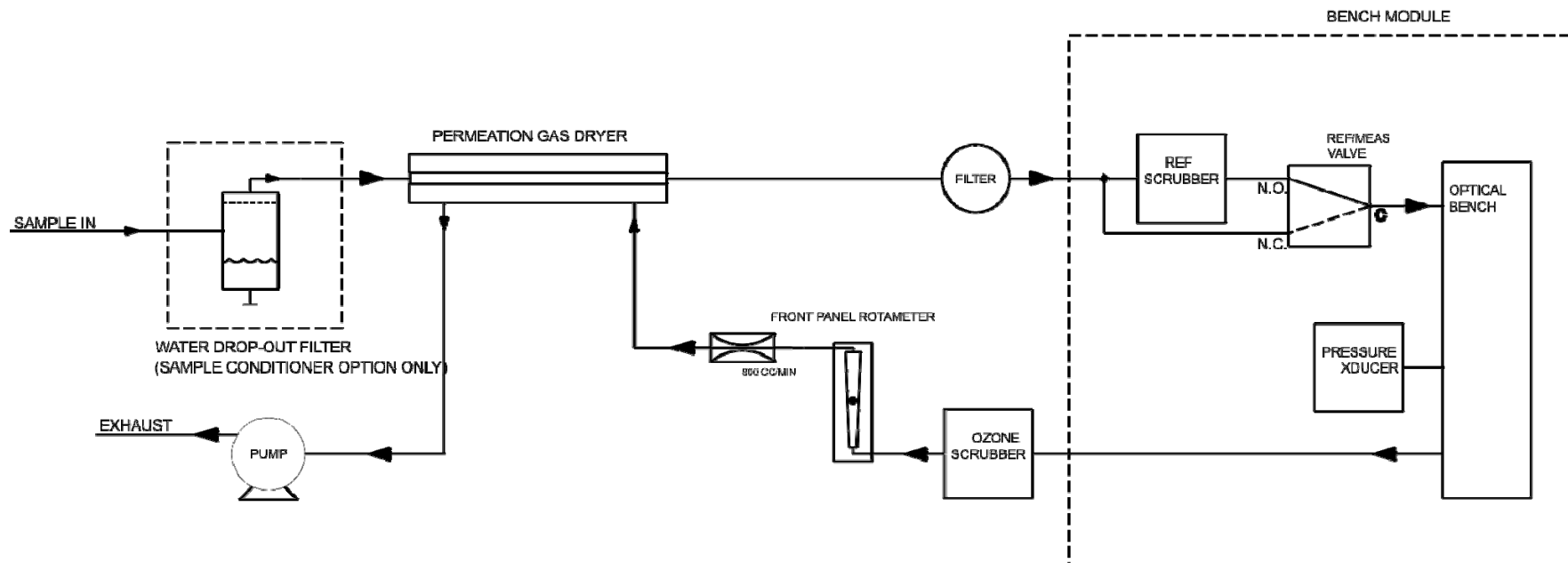


Figure 4-4. M465L Pneumatic Diagram with Sample Conditioner and Permeation Gas Dryer Options (in single-stream configuration)

## Sample Conditioner Option

The Sample Conditioner option is a water drop-out filter and a permeation gas dryer, designed for high-humidity environments where the sampling gas has been saturated with water vapor and may contain small amounts of condensed water. This coalescing filter removes not only liquid, but also particulates with a Teflon filter element. Refer to Section 9.8 for maintenance procedures.

Due to the additional volume added by the water drop-out filter, there is an exception to the Response Time in the M465L specifications:

The Response Time of an M465L instrument equipped with the Sample Conditioner option, will be <60 seconds to 95%.



**CAUTION**

**The Sample Conditioner will NOT protect the unit from damage by large amounts of liquid, such as that ingested through immersion of the sample line.**

**Furthermore, it is important to closely track the amount of water accumulating in the Water Drop-out Filter after the monitor has been installed and running: if excessive condensation is occurring in the sample lines leading to the monitor, then heat-traced lines should also be used to minimize condensation**

The Sample Conditioner option includes a Permeation Gas Dryer, which is available as an alternate option (described next) if humidity is the only concern and there is no risk of condensation.

## Permeation Gas Dryer Option

The Permeation Gas Dryer serves to remove water vapor from sampling gas in a humid environment. It is an alternative option when there is no risk of condensation. The permeation material is a Teflon Type compound and has only a minimal effect on the ozone concentration in the sample stream. When the M465L is equipped with this option, the unit has been calibrated at the factory to compensate for any ozone loss in the permeation dryer.

### 4.1.2. Exhaust Connection

Connect a ¼” OD vent line to the “Exhaust” fitting on the rear panel. This line must be vented outdoors or to an appropriate discharge system capable of handling ozone. Local regulations regarding the discharge of ozone to the atmosphere must be observed. Note that the monitor may be equipped with an internal ozone scrubber for removal of ozone from the exhaust stream. For safety reasons, the exhaust port must still be vented appropriately as described above.

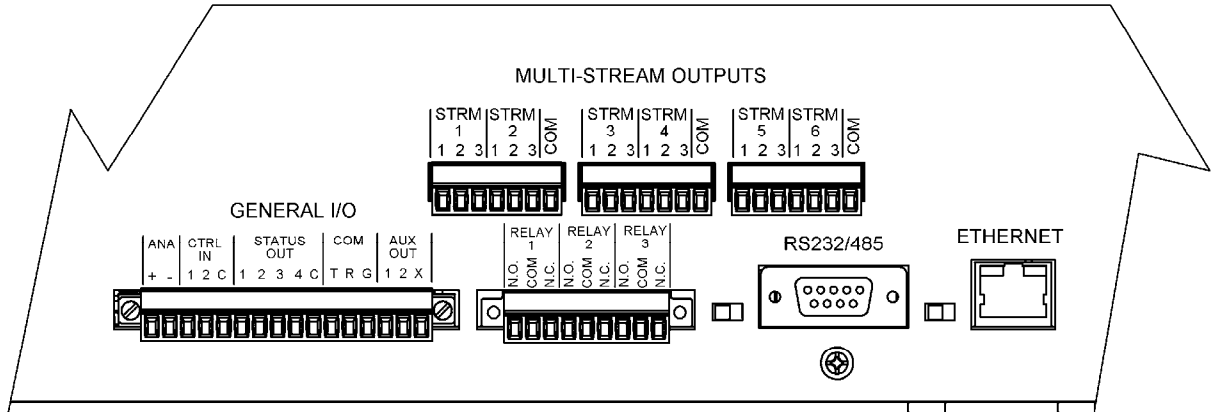


Figure 4-5: Rear Panel Electrical I/O Connections

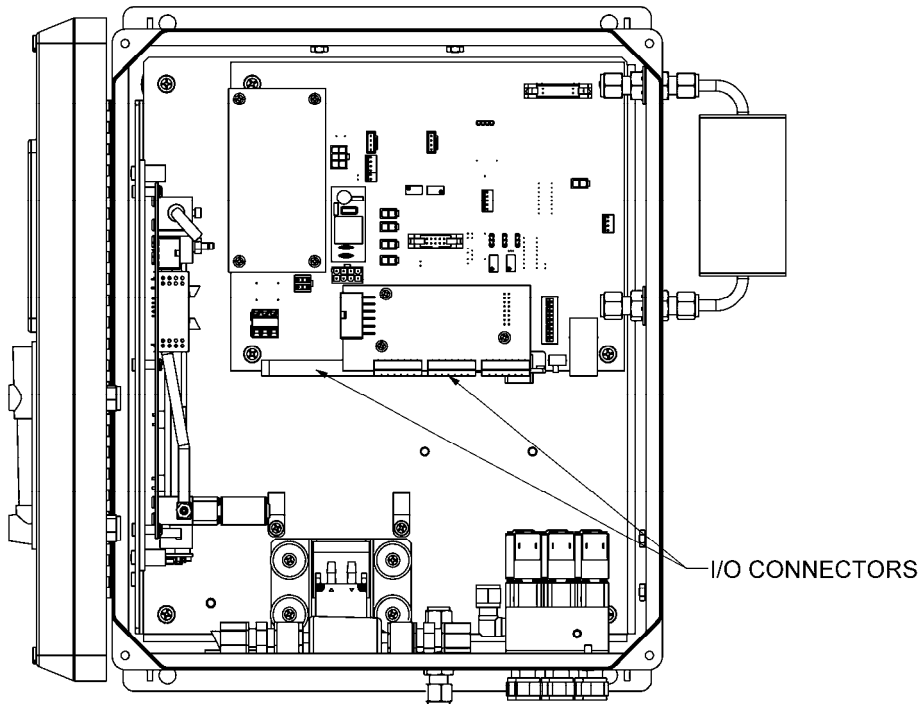


Figure 4-6: NEMA Electrical I/O Connections

## 4.2. Electrical I/O Connections

### 4.2.1. Location of I/O Connectors in the NEMA Configuration

In the NEMA configuration of the M465L, the I/O connectors are located internally in the instrument. See Figure 4-6 for their location. The relative position of the connectors and the pinout information is the same as the Rack-Mount configuration shown in Figure 4-5. Connection to these terminals is usually made via a conduit connection to the NEMA enclosure. A standard conduit penetration may be added to one of the walls of the enclosure for this purpose, or the existing penetration may be used.

### 4.2.2. Analog Output

The analog output is located at the “General I/O” connector (See Figure 4-5) and is labeled “ANA.” The analog output can be configured for 0-5V voltage or 4-20 mA current output. See Section 9.8 for details on verifying or changing the analog output hardware configuration.

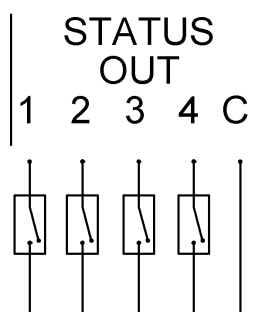
The analog output is automatically scaled to the range of the instrument, i.e. if the monitor range is 1000 PPB, then 5V would correspond to 1000 PPB and 0V would correspond to 0 PPB. See Section 7.2.7 for information on changing the range of the monitor.

The M465L has an analog output step-test mode that can be used for verifying the operation of the analog output and calibration of external measurement equipment. This mode is described in Section 7.2.3.1.

### 4.2.3. Status Outputs

There are four instrument status outputs located at the “General I/O” connector. These status outputs mirror the state of the four diagnostic LEDs on the front panel.

Electrically these outputs are SPST dry contact relay closures with a common contact, labeled ‘C’ on the rear panel. They are capable of switching up to 50 VDC, 250mA maximum current. There are no polarity requirements, so the outputs can be used to sink or source current from the ‘C’ pin, within the maximum voltage and current specified. Schematically, the outputs look as shown in Figure 4-7 below:

**Figure 4-7: Status Output Schematic**

The outputs are defined as follows:

**Table 4-1: Status Output Definitions**

Status Output #	Name	Normal Operating State
1	Sensor OK	On
2	Invalid Reading	Off
3	Check Lamp	Off
4	Pneumatic Error	Off

## 4.2.4. Hi-Current Relay Outputs

Three form C relay outputs are provided on the rear panel on the nine pin connector (See Figure 4-5). The relays are labeled “Relay 1,” “Relay 2,” and “Relay 3.”

The relays are dry contact type form C (SPDT) relays with Normally Open (N.O.), Normally Closed (N.C.) and Common (COM) contacts. The relays are capable of driving loads of up to 250VAC, 10A. For maximum contact life, the relays should only be used to drive resistive loads. Contact life may be dramatically shortened if inductive loads are driven without any provision for minimizing high voltage “inductive kick” that can occur.

These relays have slightly different functions depending on whether the monitor is a single stream or multi-stream configuration.

**Table 4-2: Relay Functions for Single Stream Config**

Relay #	Function	Normal Operating State
1	System OK Diagnostic	On
2	Hi Alarm	Off
3	Hi-Hi Alarm	Off

**Table 4-3: Relay Functions for Multi-Stream Configs**

Relay #	Function	Normal Operating State
1	System OK Diagnostic	On
2	Global Hi Alarm*	Off
3	Global Hi-Hi Alarm*	Off
* The state of the global alarm represents all the Hi or Hi-Hi alarm states OR'd together, i.e. if the Hi alarm for one or more of the sample streams is activated, then the Global Hi alarm will be activated.		

## 4.2.5. Multi-Stream Relay Outputs (Optional)

For instruments configured with the optional stream-selector, an additional set of output relays are provided on the rear panel and are labeled “Multi-Stream Outputs” (See Figure 4-5.)

Electrically these outputs are SPST dry contact relay closures with a common contact, labeled ‘C’ on the rear panel. They are capable of switching up to 50 VDC, 250mA maximum current. There are no polarity requirements, so the outputs can be used to sink or source current from the ‘C’ pin. One common terminal is provided for the six relays on each connector (See Figure 4-5.)

Each available stream has a set of 3 relays providing the following information:

**Table 4-4: Multi-Stream Relays**

<b>Relay #</b>	<b>Function</b>	<b>Meaning</b>
1	Stream ID	Stream X is active
2	Hi Alarm	Stream X Hi Alarm is active
3	Hi-Hi Alarm	Stream X Hi-Hi Alarm is active

## 4.2.6. Digital Serial Interfaces

There is one external communications port available on the Model 465 that can be configured as RS232, RS485 (Half Duplex,) or Ethernet (10Mbit.) This section provides only a brief overview of the digital serial connections. See Section 8 for more detailed information on configuring and using the digital serial interfaces.

### 4.2.6.1. RS232 Connection

With the instrument configured for RS232, connection can be made to the DB-9 connector, labeled “RS232/485”, or to the three “COM” pins on the “General I/O” connector. See Section 8.2 for additional details.

When using RS232, a 9 pin serial cable can be used to connect the instrument to a standard PC (personal computer) serial port. T-API can provide this cable, please see the spare parts list in Appendix A.

### 4.2.6.2. RS485 Connection

With the instrument configured for RS485, connection can be made to the DB-9 connector, labeled “RS232/485”, or to the three “COM” pins on the “General I/O” connector. See Section 8.2 for additional details.

### 4.2.6.3. Ethernet Connection

With the instrument configured for Ethernet, connection should be made to the RJ-45 port labeled “Ethernet.” Connection can be made using a standard Category 5 or better network patch cable. T-API can provide an appropriate cable, please see the spare parts list in Appendix A. See Section 8.2 for additional details.

## 5. FREQUENTLY ASKED QUESTIONS

---

1. Q: How long does the UV Lamp last?  
A: The typical lifetime is about 2-3 years.

## 6. OPTIONS

---

Following are descriptions of options available for the M465L.

### 6.1. Stream Selector (3 or 6 Stream)

This option allows the M465 to measure ozone at up to six different sampling points by using an internal stream selector. 3 or 6 channel stream selectors are available. This option includes digital outputs for HI and HI-HI alarms and a channel ID for each channel in the stream selector.

### 6.2. Disposable Sample Inlet Filters

This option consists of 50 disposable filters for installation at the inlet end of all sample lines.

### 6.3. Rack Mount Slides

Rack mount slides can be attached to the sides of the instrument, allowing it to slide completely out of a RETMA rack, facilitating maintenance activities.

### 6.4. Electronic Flowmeter

The M465 can be fitted with an internal electronic flowmeter that enables the instrument to display the flow digitally on the front panel and provides a Pneumatic Error if the flow is outside its normal limits.

### 6.5. Sample Conditioner

For humid environments where there is risk of water condensation in the sample lines, this option serves to filter out liquid and particulates and includes a permeation gas dryer as well. For details, see “Sample Conditioner” in Section 4.1.1.2.

### 6.6. Permeation Gas Dryer

This option removes water vapor from the sample stream in environments where humidity is a concern but where condensation is not a factor. For details, see “Permeation Gas Dryer” in Section 4.1.1.2.

This page intentionally left blank.

# 7. OPERATION

---

## 7.1. Front Panel Overview

The M465L front panel provides a number of functions in addition to displaying the current ozone concentration being measured. Figure 7-1 below shows the display and keypad portion of the front panel.

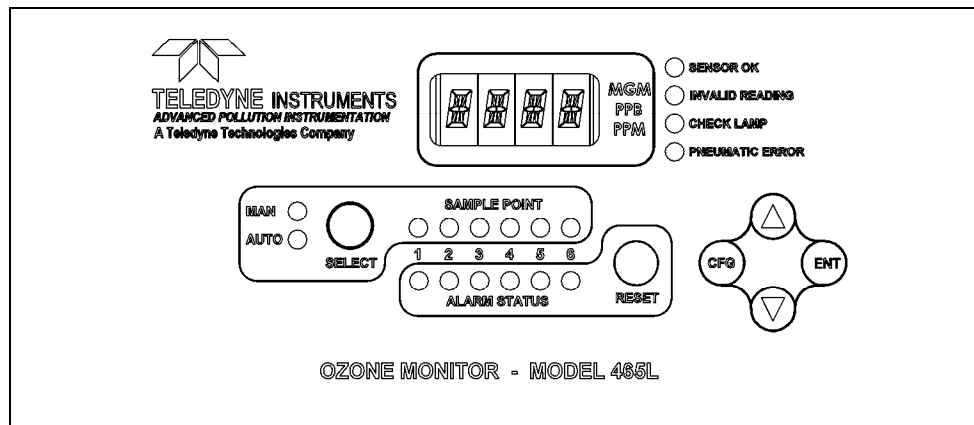


Figure 7-1: Front Panel Display

### 7.1.1. Ozone Concentration Display

The 4-character LED display in the center of the front panel normally shows the current ozone concentration being measured by the M465. While displaying concentration, one of the unit-of-measure indicators (i.e., PPM, PPB, or UGM) should be backlit, indicating the current measurement units. If none of these indicators are backlit, then the display is in Menu mode or Startup mode and is not displaying the concentration. If the display is in Menu mode, the display can be returned to Concentration mode by repeatedly pressing the CFG button until one of the unit-of-measure indicators is lit. Note that even when the display is in Menu mode, normal measurement and stream selector operation will continue in the background.

### 7.1.2. Menu Navigation Keypad

The menu navigation keypad (CFG, ENT and UP/DOWN buttons) is used to navigate the various menu items available on the M465L. The menus allow the user to view operational parameters of the instrument as well as view and modify the configuration of the instrument. See Section 7.2 for more detailed information.

### 7.1.3. Stream Selector Status/Control (Optional)

The optional multi-channel stream selector can be controlled via the front panel. The stream selector operates in two modes, Auto and Manual. The Auto mode is normally the default mode. The 'AUTO' and 'MAN' LED's show the current mode. To switch modes, press and hold the **SELECT** button for at least 2 seconds. When in Manual mode, momentarily pressing the **SELECT** button will switch to the next stream.

The stream selector status is shown by the six LED's labeled 'SAMPLE POINT.' One of the LED's should always be lit, showing the current channel being measured. Note that for a three-channel instrument, only streams 1-3 can be measured. See Section 7.3 for additional details on the operation of the stream selector.

When the instrument is in its default configuration, there is a Manual mode timeout feature that will automatically return the stream selector to Auto mode when no keys are pressed for 10 minutes. This is the recommended setting for instruments used for critical safety applications. This feature prevents the instrument from being inadvertently left in Manual mode, and subsequent loss of monitoring data from the other, unmeasured channels. For applications where Manual mode is the preferred mode of operation, this timeout feature can be turned off. See Section 7.2.6 for details on changing this setting.

### 7.1.4. Concentration Alarm Status/Reset

The M465L front panel displays the concentration alarm status of all channels being sampled. The row of LED's labeled 'ALARM STATUS' shows the alarm status for each channel as follows:

Table 7-1: Alarm LED's

Alarm Status LED Color	Alarm State
Green	No alarm active
Amber	'HI' alarm active
Red	'HI-HI' alarm active

If the alarms are configured for latching operation, then the **RESET** button can be used to attempt to reset all alarms. Note that alarms can only be reset if the concentration measured for a specific channel has subsequently dropped below the alarm limit. If the alarms are configured for non-latching operation, they will be automatically cleared when the concentration falls below the alarm threshold. The **RESET** button has no effect when the alarms are configured for non-latching operation.

See Sections 7.2.7, 4.2.4, and 4.2.5 for additional details on concentration alarms.

## 7.1.5. Status LEDs

There are four Status LED's on the front panel to the right of the concentration display. These LED's provide a quick view of the instrument's Status as well as an indication of any problems that may exist. The normal state for these LED's after the initial 20 minute warm-up period is as follows:

**Table 7-2: Status LED's**

Status LED	Normal State
Sensor OK	ON
Invalid Reading	OFF
Check Lamp	OFF
Pneumatic Error	OFF

If any of these LED's are in a different state than shown above, then some adjustment or troubleshooting should be performed. See Section 10.1 for more detailed information.

## 7.2. Front Panel Menus

The M465L has an interactive menu structure that can be operated from the front panel. From within this menu structure, the operator can view real-time parameters such as temperature and pressure, view configuration information, and edit setup parameters such as alarm limits.

Figure 7-2 below shows the menu structure as well as the buttons that are used to navigate it.

Starting with the display in Concentration mode, press **CFG** to enter Menu mode. At this point the unit-of-measure LED should turn off and the first level of the Menu tree will be active. Pressing the **UP/DOWN** arrows will now select from the items available at this menu level. Press **ENT** to enter one of these sub-menus or press **CFG** to back out of this menu level back to Concentration mode.

### 7.2.1. Menu Navigation Basics

1. Press **CFG** from Concentration mode to enter Menu mode.
2. Once in Menu mode, **CFG** will move backwards one level in the menu structure and **ENT** will move forward.
3. Each menu level contains an EXIT selection. Selecting EXIT and pressing **ENT** will exit the Menu mode and return the display to Concentration mode.
4. The Menu mode will timeout if no buttons are pressed within 30 seconds, and the instrument will automatically return to Concentration mode.

## 7.2.2. Editing Numeric Values

At certain places in the menu structure the operator can edit numeric values. The menu buttons behave somewhat differently when in this mode.

Press **CFG** to select a digit to edit. The selected digit will blink. Next press the **UP/DOWN** arrows to increment/decrement the selected digit. Press **CFG** again to select another digit. Pressing **CFG** at the last digit will wrap back to the first digit.

Once all the digits have been edited, press **ENT** to accept the new value.

To abort the editing process without changing the original value, press and hold the **CFG** button until the display returns to the previous menu level.

Note that limit checking is enforced while editing values and changes that would result in invalid values are ignored.

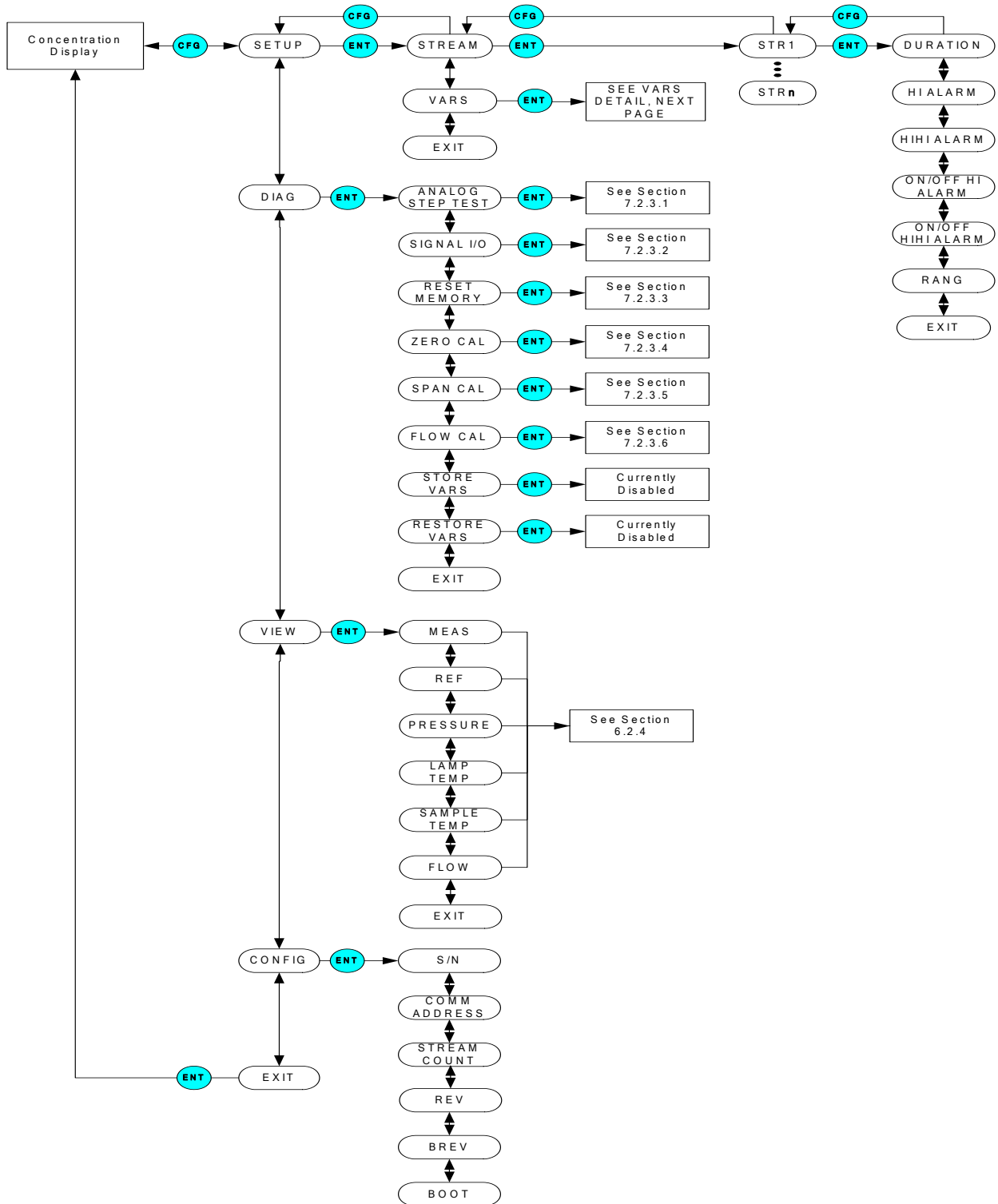


Figure 7-2: Front Panel Menu Diagram (Page 1)

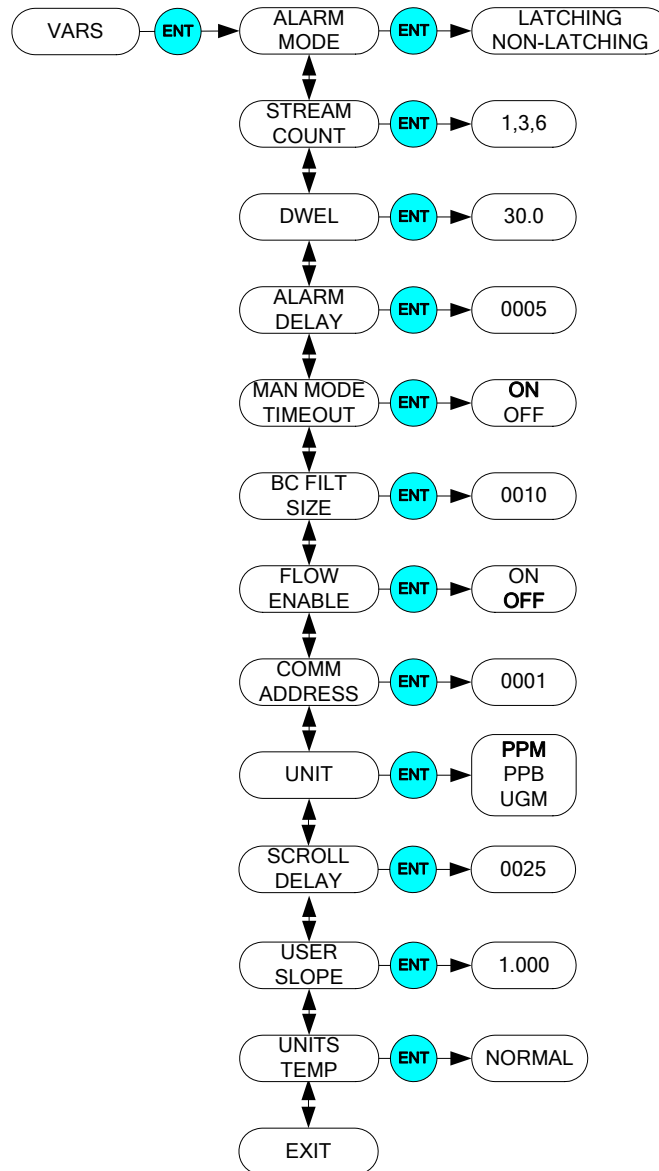


Figure 7-3: Front Panel Menu Diagram (Page 2)

## 7.2.3. DIAG Menu

The DIAG menu (See

Figure 7-2) contains functions that are useful for testing and configuring external equipment that may be connected to the rear panel I/O of the instrument.

### 7.2.3.1. Analog Step-Test

When placed in this mode, the instrument will automatically step the analog output (See Section 4.2.2 for details on the analog output connection) through 5 points from 0 to 100 % and display the current value on the front panel. The operator can suspend the automatic cycling and manually control the stepping by pressing either one of the **UP / DOWN** arrow buttons. To resume automatic cycling, exit the function by pressing **CFG** and re-enter by pressing **ENT**.

The 5 points will correspond to the following analog output values depending on whether the output is configured for 0-5V or 4-20mA:

**Table 7-3: Analog Step Test Values**

<b>Point</b>	<b>0-5V Output</b>	<b>4-20 mA Output</b>
0%	0.00 V	4 mA
25%	1.25 V	8 mA
50%	2.50 V	12 mA
75%	3.75 V	16 mA
100%	5.00 V	20 mA

Press **CFG** to exit from the Analog Step-Test function.

### 7.2.3.2. Signal I/O

The Signal I/O menu allows the operator to manually control the various relay outputs and control inputs available on the rear panel of the M465L. This function is useful for testing or debugging external control systems (i.e. dataloggers or PLC's) to which the instrument may be connected.

See Section 4.2 for additional details on making connections to these I/O signals on the rear panel.

See

Figure 7-2 for additional details on entering the Signal I/O menu.

**Table 7-4: Signal I/O List**

Signal Name	Rear Panel Label	Function
AUX 1 IN	CTRL IN - 1	UNDEFINED
AUX 2 IN	CTRL IN - 1	UNDEFINED
RELAY 1	RELAY 1	SENSOR OK
RELAY 2	RELAY 2	GLOBAL HI ALARM
RELAY 3	RELAY 3	GLOBAL HI-HI ALARM
STAT OUT 1	STATUS OUT - 1	SENSOR OK
STAT OUT 2	STATUS OUT - 2	INVALID READING
STAT OUT 3	STATUS OUT - 3	CHECK LAMP
STAT OUT 4	STATUS OUT - 4	PNEUMATIC ERROR
STAT AUX 1	AUX OUT - 1	UNDEFINED
STAT AUX 2	AUX OUT - 2	UNDEFINED
XRELAY 1	STRM 1 - 1	STREAM 1 ACTIVE
XRELAY 2	STRM 1 - 2	STREAM 1 HI ALARM
XRELAY 3	STRM 1 - 3	STREAM 1 HI-HI ALARM
XRELAY 4	STRM 2 - 1	STREAM 2 ACTIVE
XRELAY 5	STRM 2 - 2	STREAM 2 HI ALARM
XRELAY 6	STRM 2 - 3	STREAM 2 HI-HI ALARM
XRELAY 7	STRM 3 - 1	STREAM 3 ACTIVE
XRELAY 8	STRM 3 - 2	STREAM 3 HI ALARM
XRELAY 9	STRM 3 - 3	STREAM 3 HI-HI ALARM
XRELAY 10	STRM 4 - 1	STREAM 4 ACTIVE

Signal Name	Rear Panel Label	Function
XRELAY 11	STRM 4 – 2	STREAM 4 HI ALARM
XRELAY 12	STRM 4 - 3	STREAM 4 HI-HI ALARM
XRELAY 13	STRM 5 - 1	STREAM 5 ACTIVE
XRELAY 14	STRM 5 – 2	STREAM 5 HI ALARM
XRELAY 15	STRM 5 - 3	STREAM 5 HI-HI ALARM
XRELAY 16	STRM 6 - 1	STREAM 6 ACTIVE
XRELAY 17	STRM 6 – 2	STREAM 6 HI ALARM
XRELAY 18	STRM 6 - 3	STREAM 6 HI-HI ALARM
XVALVE 1	N/A	STREAM 1 INPUT VALVE
XVALVE 2	N/A	STREAM 2 INPUT VALVE
XVALVE 3	N/A	STREAM 3 INPUT VALVE
XVALVE 4	N/A	STREAM 4 INPUT VALVE
XVALVE 5	N/A	STREAM 5 INPUT VALVE
XVALVE 6	N/A	STREAM 6 INPUT VALVE

### 7.2.3.3. Memory Reset

This function is currently disabled.

### 7.2.3.4. Zero Calibration

The zero calibration allows the instrument to calibrate its internal ozone offset factor. This should only be done with a source of zero air connected to the “Sample In” port of the M465L. Allow the instrument to stabilize on the zero air source before attempting to zero. This normally takes 10-15 minutes.

When entering the Zero Calibration menu, the prompt “ENT TO CAL” appears on the display. Simply confirm the calibration by pressing the **ENT** button to perform the calibration (to abort the calibration, press and hold the **CFG** button to return to the previous menu level.) After pressing **ENT**, the instrument will automatically exit the menu mode and return to Concentration mode. The concentration reading should quickly go to zero. Please note that while measuring zero air, a certain amount of noise or “dithering” of the concentration about the zero point will occur and is normal. This noise is typically 1-3 ppb (0.001 - 0.003 ppm) in magnitude.

### 7.2.3.5. Span Calibration

The span calibration allows the instrument to calibrate its internal slope factor based on a known ozone concentration. This should be done with a source of ozone span gas connected to the “Sample In” port of the M465L. Allow the instrument to stabilize on the span gas source for a minimum of 1 hour before performing the span calibration.

#### NOTE

A Span Calibration should only be performed with a precision source of ozone calibration gas, such as a Teledyne API Model 700 or Model 703 calibrator. Simple ozone generators without a measurement feedback system should never be used for performing span calibrations.

If you are unsure regarding the suitability of a particular source of calibration gas, contact Customer Service at Teledyne API for assistance.

Figure 7-4 below shows the Span Cal menu. After the instrument has stabilized on the source of span gas, navigate to the Span Cal menu (See

Figure 7-2) and Press **ENT**. Next enter the Span Target concentration (the actual concentration of ozone being supplied to the monitor) and press **ENT**. The display will next show a confirmation menu, **ENT TO SPAN**. Press **ENT** to perform the Span Calibration, or **CFG** to abort back to the start. If the calibration is successful, the display will return to the concentration menu and the monitor reading should change adjust to read very close to the target value. If the calibration cannot be performed, an **OUT OF RANGE** error will be displayed. Press **ENT** to confirm and the display will return to the start of the Span Cal menu.

If the **OUT OF RANGE** error occurs, it means the Span Cal cannot be performed because it would result in an out of range slope value for the monitor. This means that either the sensor in the monitor is malfunctioning, causing improper readings, or the actual ozone concentration being supplied to the monitor is different than the target value being entered.

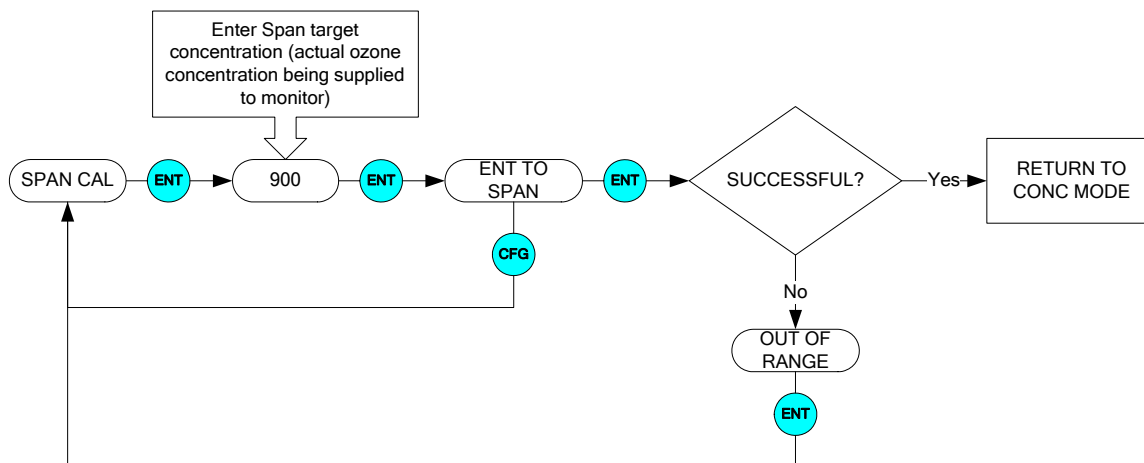


Figure 7-4: Span Cal Menu

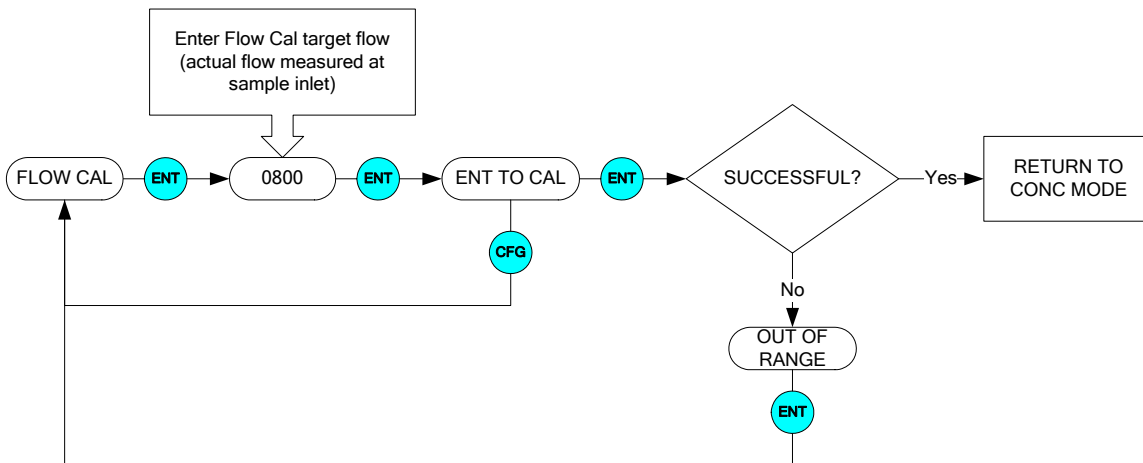
### 7.2.3.6. Flow Calibration (Optional Electronic Flowmeter only)

The flow calibration allows the instrument to calibrate its internal flowmeter reading. This should be done with a calibrated flowmeter connected to the “Sample In” port of the M465L.

Figure 7-5 below shows the Flow Cal menu. After the instrument has stabilized on the source of span gas, navigate to the Flow Cal menu (See

Figure 7-2) and Press **ENT**. Next enter the Flow Cal target (the actual flow as measured at the sample inlet) and press **ENT**. The display will next show a confirmation menu, **ENT TO CAL**. Press **ENT** to perform the Flow Calibration, or **CFG** to abort back to the start. If the calibration is successful, the display will return to the concentration. If the calibration cannot be performed, an **OUT OF RANGE** error will be displayed. Press **ENT** to confirm and the display will return to the start of the Flow Cal menu.

If the **OUT OF RANGE** error occurs, it means the Flow Cal cannot be performed because it would result in an out of range flow slope value for the monitor. This means that either the flow sensor in the monitor is malfunctioning, causing improper readings, or the actual flow is different than the target value being entered.



**Figure 7-5: Flow Cal Menu**

## 7.2.4. VIEW Menu

The VIEW menu allows the operator to view various measurement parameters in real-time. This can be useful for diagnosing various instrument or system problems.

Note that these values are updated in real-time as they are repeatedly scrolled on the display.

**Table 7-5: VIEW Menu Parameters**

Parameter	Meaning	Units	Normal Range*
MEAS	UV detector reading, measure cycle	mV	250 – 1230
REF	UV detector reading, reference cycle	mV	250 – 1230
PRESSURE	Sample pressure	psia	9.0 – 14.9
LAMP TEMP	UV lamp temperature	°C	50.0 – 52.0
SAMPLE TEMP	Sample temperature	°C	5.0 – 50.0
FLOW	Sample Gas Flow Rate	cc/min	640 – 960
*After initial 20 minute warm-up period.			

## 7.2.5. CONFIG Menu

The CONFIG menu displays specific information related to the instrument's configuration. No changes are made within this menu.

**Table 7-6: CONFIG Menu Parameters**

CONFIG	Meaning
S/N	Serial number of M465L. (Should match the serial number tag on the rear panel of the instrument).
COMM ADDRESS	Displays the MODBUS slave ID for the instrument.
STREAM COUNT	Displays the number of streams configured. (Always 1 for instruments without the Multi-stream Option).
REV	Revision of instrument firmware
BREV	Revision of sensor firmware
BOOT	Revision of bootloader firmware

## 7.2.6. SETUP-VARS Menu

The VARS menu allows viewing and editing of various global setup variables that effect how the M465L operates. These variables are stored in the instrument's non-volatile memory. Table 7-7 lists these variables and their function.

**Table 7-7: VARS List**

VAR	Meaning	Default Value	Range
S/N	Serial number of M465L. This number should match the serial number tag on the rear of the instrument.	N/A	1-9999
ALARM MODE	Controls the latching behavior of the concentration alarms. See Section 7.1.4 for additional details.		LATCHING, NON-LATCHING
STREAM COUNT*	Specifies the number of streams available in the instrument. Note that the hardware in the instrument must be also configured to support the number of streams specified.	1	1,3,6
DWEL	Dwell value for stream selector operation. See Section 7.3 for additional details.	30.0 Seconds	0.0 – 30.0 Seconds
	Multi-stream units with the Sample Conditioner option (Section 4.1.1.2), require additional dwell time to purge the filter between stream measurements.	45.0 Seconds	0.0 – 45.0 Seconds
ALARM DELAY	Number of readings above alarm limit required to trigger alarms	5	1 - 10
MAN MODE TIMEOUT	Enables/disables the Manual mode timeout feature. See Section 7.1.3 for more detail.	ON	ON, OFF
BC FILT SIZE*	Boxcar filter length for concentration filter. Increasing the size of the filter will smooth out the concentration readings but will also increase the response time.	10	1-30
FLOW ENABLE	Enables/disables operation of optional electronic flowmeter	OFF	ON, OFF
COMM ADDRESS	MODBUS address for serial communications	1	1 - 20
UNIT	Concentration unit-of-measure setting.	PPM	PPM, PPB, UGM
SCROLL DELAY	Inter-character delay for the front panel display, to increase speed (lower value) or decrease speed (higher value) the display scroll.	20	6-100
USER SLOPE	User-editable calibration slope value	1.000	0.5 – 1.5
UNITS TEMP	Standard (20°C) or Normal (0°C) temperature selection for g/Nm <sup>3</sup> units of measure.	NORMAL	NORMAL STANDARD
* Changing the value of these VARS forces the instrument to automatically reboot for the changes to take effect.			

## 7.2.7. SETUP-STREAM Menu

The STREAM menu allows the operator to view and edit properties of each measurement stream available. For each stream the following properties are available:

**Table 7-8: STREAM Properties**

Property	Meaning	Default Value	Range
DURATION	Stream measurement duration for AUTO stream-selector operation. See Section 7.3 for additional details.	60.0 Seconds	60.0 – 360.0 Seconds
HI ALARM	HI alarm trigger value	0.100 PPM	.010 – 9.999 PPM*
HIHI ALARM	HI-HI alarm trigger value	0.300 PPM	.010 – 9.999 PPM*
ON/OFF HI ALARM	HI alarm enable, enables HI alarm operation	ON	ON/OFF
ON/OFF HI HI ALARM	HI-HI alarm enable, enables HI-HI alarm operation	ON	ON/OFF
RANG	Concentration range for specified stream. Used to scale the analog output.	1.0 PPM	1.0 – 500.0 PPM

\* For low concentration instrument ranges. For certain range configurations, the alarms may be set to higher values

## 7.3. Multi-Stream Operation

This section describes the operation of the Multi-Stream M465 in Automatic mode (AUTO) and Manual mode (MAN.)

In AUTO mode the monitor is designed to continuously cycle through the available sampling streams. In MAN mode the operator manually controls the stream cycling by pressing the **SELECT** button. The stream cycling is accomplished by activating valves on the stream selector manifold on the rear panel to admit sample gas for a particular stream. Section 7.1.3 details the operation of the front panel stream selector interface.

When the M465L first switches to a new sample stream, the instrument goes through a 30 second dwell phase where sample gas is pulled from the new sample stream but no readings are taken. The purpose of this dwell phase is to purge out any “old” sample gas that has been sitting in the sample line while that stream was inactive. During the dwell phase the Sample Point LED on the display (See Figure 7-1) will blink and the concentration display will show the last concentration recorded for that stream. After the 30 seconds has elapsed, the Sample Point LED will stop blinking and the current concentration will be displayed. The current stream will now be monitored for the rest of the measurement Duration that has been set for that stream (see Section 7.2.7 for details on configuring the individual streams.) The actual time period that the stream is measured is the measurement Duration minus the 30 second dwell. So a 1 minute measurement Duration consists of 30 seconds of dwell followed by 30 seconds of measurement.

For systems that do not require a 30 second dwell between streams, this value can be changed using the DWEL Var. See Section 7.2.6 for additional details.

## 8. DIGITAL COMMUNICATIONS

---

### 8.1. Digital Communications Overview

The M465L comes equipped with a digital communications (Com) port that can be connected to a computer or digital data acquisition system. This Com port uses the standardized MODBUS® protocol and can be configured for RS232, RS485, or Ethernet (10 Mbit,) allowing for connections to a wide variety of devices and networks. See Section 8.2 for more information on configuring the Com port.

The Com port can be used for data acquisition, alarm triggering, and instrument configuration. All the functions that are available at the front panel of the instrument can also be performed over the Com port.

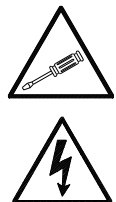
#### NOTE

MODBUS Interface Software for the M465L is available for download from the T-API website. Other TAPI software, such as APICom, does not currently support communications with the M465L.

### 8.2. Changing Com Port Hardware Configuration

#### CAUTION

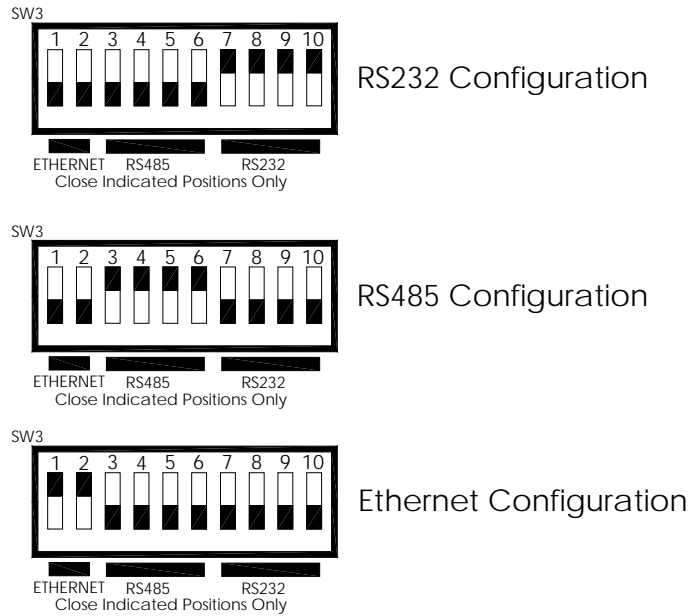
RISK OF ELECTRICAL SHOCK. THE OPERATIONS OUTLINED IN THIS SECTION ARE TO BE PERFORMED BY QUALIFIED MAINTENANCE PERSONNEL ONLY!



The Com port can be configured for RS232, RS485, or Ethernet. To change the Com port hardware configuration, perform the following steps:

1. Disconnect power from the M465L.
2. Remove the six screws and the top cover.
3. Locate the DIP switches labeled SW3 on the rear portion of the mainboard.
4. Turn ON the switches specified for the desired Com configuration (See Figure 8-1.) All other switches on SW3 should be OFF.
5. Locate SW2 (DTE-DCE switch) on mainboard.

6. For RS-232 operation, set SW2 to either DTE or DCE (See Section 8.3.) For RS-485 operation, set SW2 to DCE.
7. Re-install the instrument cover.
8. Re-connect power to the instrument.
9. The software portion of the Com port configuration will now automatically be completed after the next instrument boot-up.



**Figure 8-1: Com Configuration Jumper Settings (SW2)**



**NOTE**

To avoid start-up problems, ensure that there are no devices attempting communication with the instrument during start-up. Once the sign-on message is displayed on the front panel, it is safe to begin communications.

## 8.3. RS-232 Configuration

The RS-232 configuration is usually used when making a one-to-one connection between the instrument and a single computer or PLC. The communications protocol used for the RS-232 configuration is MODBUS RTU. For details on the MODBUS RTU specification, please see <http://www.modbus.org/>.

With the instrument configured for RS-232, connection can be made to the DB-9 connector, labeled “RS232/485”, or to the three “COM” pins on the “General I/O” connector. Only one of these connections should be used, the other must be left un-connected. Table 8-1 below details the pinouts of these two connectors:

**Table 8-1: RS-232 Connector Details**

Function	DB-9 Connector Pin (SW2 – DTE)	DB-9 Connector Pin (SW2 – DCE)	General I/O Connector
Transmit (Tx)	3	2	‘T’
Receive (Rx)	2	3	‘R’
Ground	5	5	‘G’

Note that a DTE-DCE switch is provided so that the instrument can be connected to another device using either a straight-through or crossover (Null-Modem) cable. See Section 8.2 for details on changing this configuration.

The serial port setup for RS-232 configuration is shown in Table 8-2 below:

**Table 8-2: RS-232 Port Setup**

Property	Value
Baud Rate	57600
Data Bits	8
Parity	None
Stop Bits	1
Flow Control	None

## 8.4. RS-485 Configuration

RS-485 is commonly used for factory automation busses with a computer or PLC acting as a master. The communications protocol used for the RS-485 configuration is MODBUS RTU. For details on the MODBUS RTU specification, please see <http://www.modbus.org/>.

With the instrument configured for RS-485, connection can be made to the DB-9 connector, labeled “RS232/485”, or to the three “COM” pins on the “General I/O” connector. Table 8-3 below details the pinouts of these two connectors:

**Table 8-3: RS-485 Connector Details**

Function	DB-9 Connector Pin (SW2 – DCE)	General I/O Connector
RS485 - A	2	‘T’
RS485 - B	3	‘R’
Ground	5	‘G’

Note that for RS-485, the DTE-DCE switch should always be set to DCE. See Section 8.2 for details on changing this configuration.

The serial port setup for RS-485 configuration is shown in Table 8-4 below:

**Table 8-4: RS-485 Port Setup**

Property	Value
Baud Rate	57600
Data Bits	8
Parity	None
Stop Bits	1
Flow Control	None

## 8.5. Ethernet Configuration

Ethernet is commonly used for factory automation busses with a computer or PLC acting as a master. The communications protocol used for the Ethernet configuration is MODBUS TCP/IP. For details on the MODBUS TCP/IP specification, please see <http://www.modbus.org/>.

A Windows software application, *DeviceInstaller*, is available for configuring the Ethernet module used in the M465L. This application is available for download here:

<http://www.teledyne-api.com/software/>

### 8.5.1. Hardware Setup for Configuring the Ethernet Module

To make the first-time configuration of the Ethernet module as easy as possible, the module comes from the factory with DHCP enabled. The M465L can simply be plugged into a network with a DHCP server and an IP Address should be automatically assigned to, and stored in, the device.

A simple network can easily be constructed for this purpose by using a small broadband router commonly used for home networks. The M465L and a PC can then be connected to the router and the router's DHCP server will assign IP Addresses to both the PC and the M465L, enabling them to communicate.

### 8.5.2. Verifying Network Hardware Connection

With the M465L connected to a network and powered up, check the status of the two leds on the Ethernet connector on the rear panel. The left-hand LED should be lit; either amber or green indicating link status and the right-hand led should blink periodically, indicating activity on the network. See Table 8-5 below for more details on the status LED's.

If neither of the LED's are lit, then the Ethernet module may not be powered up or the instrument may not be connected to a valid network. Check the COM port configuration per Section 8.2 and make sure that it is set to "Ethernet."

**Table 8-5: Ethernet LED Definitions**

Link LED (Left Side)		Activity LED (Right Side)	
Color	Meaning	Color	Meaning
Off	No Link	Off	No Activity
Amber	10 Mbps Connection	Amber	Half-Duplex
Green	100 Mbps Connection	Green	Full-Duplex

### 8.5.3. Determining a Dynamically Assigned IP Address (DHCP Mode)

The *DeviceInstaller* software application (See Section 8.5) can be used to search a network for instruments and determine the IP Address assigned by a DHCP server.

1. Click **Start->Programs->Lantronix DeviceInstaller->DeviceInstaller**. If your PC has more than one network adapter, a message displays. Select an adapter and click **OK**.
2. Click on the **Search** icon. After a moment a list of instruments on the network will be displayed. The M465L should be listed as an **XPORT-IAP** type device.
3. Double-click on the device in the right-hand section of the *DeviceInstaller* window; a list of configuration parameters will be shown, including the IP Address. If multiple devices are shown, the correct one can be determined by matching the Hardware Address shown with the address printed on the label of the Ethernet module in the M465L. Note that the instrument cover must be removed to inspect this address in the instrument.

### 8.5.4. Manually Assigning a Static IP Address

For applications where the IP Address must remain constant, a static IP Address can be manually assigned to the instrument and the DHCP function must be disabled.

1. Click **Start->Programs->Lantronix DeviceInstaller->DeviceInstaller**. If your PC has more than one network adapter, a message displays. Select an adapter and click **OK**.

**Note:** *If the unit already has an IP address (e.g., DHCP has assigned an IP address), click the **Search** icon and select the unit from the list of Lantronix device servers on the local network.*

2. Click the **Assign IP** icon.
3. If prompted, enter the hardware address (on the product label) and click **Next**.
4. Select **Assign a specific IP address** and click **Next**.
5. Enter the **IP address**. The **Subnet mask** displays automatically based on the IP address; if desired, you may change it. On a local network, you can leave the **Default gateway** blank (all zeros). Click **Next**.
6. Click the **Assign** button and wait several seconds until a confirmation message displays. Click **Finish**.
7. Select the device from the main window list and select **Ping** from the **Tools** menu. The Ping Device dialog box shows the IP address of the selected unit.
8. From the **Tools** menu, click the **Ping** button. The results display in the Status window. Click the **Clear Status** button to clear the window so you can ping the device again.

**Note:** *If you do not receive "Reply" messages, make sure the unit is properly attached to the network and that the IP address assigned is valid for the particular network segment you are working with. If you are not sure, check with your systems administrator.*

9. Click the **Close** button to close the dialog box and return to the main window.

## 8.6. MODBUS Register Maps

### 8.6.1. MODBUS Commands Supported

Table 8-6 lists the MODBUS commands that are supported by the M465L. Note that the “Write” commands will only work with registers that are configured as Read/Write, see Section 8.6.4. The “Read” commands can be used with any register.

**Table 8-6: Supported MODBUS Commands**

<b>MODBUS Function Code</b>	<b>Description</b>
01	Read Coils
02	Read Discrete Inputs
03	Read Holding Registers
04	Read Input Registers
05	Write Single Coil
06	Write Single Register
15	Write Multiple Coils
16	Write Multiple Registers

### 8.6.2. Notes on MODBUS registers

Concentration values in the MODBUS registers are always expressed in units of PPB (parts-per-billion,) regardless of the concentration units setting of the monitor.

### 8.6.3. Real-Time Concentration and Status Registers (Read Only)

Decimal Address	Description	Register Type	Start Bit	# Bits
1	Stream 1 Concentration (PPB)	Float Inverse	0	32
3	Stream 2 Concentration (PPB)	Float Inverse	0	32
5	Stream 3 Concentration (PPB)	Float Inverse	0	32
7	Stream 4 Concentration (PPB)	Float Inverse	0	32
9	Stream 5 Concentration (PPB)	Float Inverse	0	32
11	Stream 6 Concentration (PPB)	Float Inverse	0	32
13	Stream 1 HI Alarm Status, 1= ON	Byte	0	8
13	Stream 2 HI Alarm Status, 1= ON	Byte	8	8
14	Stream 3 HI Alarm Status, 1= ON	Byte	0	8
14	Stream 4 HI Alarm Status, 1= ON	Byte	8	8
15	Stream 5 HI Alarm Status, 1= ON	Byte	0	8
15	Stream 6 HI Alarm Status, 1= ON	Byte	8	8
16	Stream 1 HI-HI Alarm Status, 1= ON	Byte	0	8
16	Stream 2 HI-HI Alarm Status, 1= ON	Byte	8	8
17	Stream 3 HI-HI Alarm Status, 1= ON	Byte	0	8
17	Stream 4 HI-HI Alarm Status, 1= ON	Byte	8	8
18	Stream 5 HI-HI Alarm Status, 1= ON	Byte	0	8
18	Stream 6 HI-HI Alarm Status, 1= ON	Byte	8	8
19	Stream 1 Active Status, 1= Sampling	Byte	0	8
19	Stream 2 Active Status, 1= Sampling	Byte	8	8
20	Stream 3 Active Status, 1= Sampling	Byte	0	8
20	Stream 4 Active Status, 1= Sampling	Byte	8	8
21	Stream 5 Active Status, 1= Sampling	Byte	0	8
21	Stream 6 Active Status, 1= Sampling	Byte	8	8
24	Gas Flow (cc/min)	Float Inverse	0	32
39	Sensor Reference Value (mV)	Float Inverse	0	32
41	Sensor Measure Value (mV)	Float Inverse	0	32
43	Sensor Pressure Value (psia)	Float Inverse	0	32
45	Sensor Gas Temperature (K)	Float Inverse	0	32
47	Sensor UV Lamp Temp (°C)	Float Inverse	0	32

## 8.6.4. Instrument Setup and Configuration Registers (Read / Write)

Decimal Address	Description	Register Type	Start Bit	# Bits
1031	Stream 1 Monitoring Duration (s)	Float Inverse	0	32
1033	Stream 2 Monitoring Duration (s)	Float Inverse	0	32
1035	Stream 3 Monitoring Duration (s)	Float Inverse	0	32
1037	Stream 4 Monitoring Duration (s)	Float Inverse	0	32
1039	Stream 5 Monitoring Duration (s)	Float Inverse	0	32
1041	Stream 6 Monitoring Duration (s)	Float Inverse	0	32
1043	Stream 1 HI Alarm Limit (PPB)	Float Inverse	0	32
1045	Stream 2 HI Alarm Limit (PPB)	Float Inverse	0	32
1047	Stream 3 HI Alarm Limit (PPB)	Float Inverse	0	32
1049	Stream 4 HI Alarm Limit (PPB)	Float Inverse	0	32
1051	Stream 5 HI Alarm Limit (PPB)	Float Inverse	0	32
1053	Stream 6 HI Alarm Limit (PPB)	Float Inverse	0	32
1055	Stream 1 HI-HI Alarm Limit (PPB)	Float Inverse	0	32
1057	Stream 2 HI-HI Alarm Limit (PPB)	Float Inverse	0	32
1059	Stream 3 HI-HI Alarm Limit (PPB)	Float Inverse	0	32
1061	Stream 4 HI-HI Alarm Limit (PPB)	Float Inverse	0	32
1063	Stream 5 HI-HI Alarm Limit (PPB)	Float Inverse	0	32
1065	Stream 6 HI-HI Alarm Limit (PPB)	Float Inverse	0	32
1067	Stream 1 Analog Range (PPB)	Float Inverse	0	32
1069	Stream 2 Analog Range (PPB)	Float Inverse	0	32
1071	Stream 3 Analog Range (PPB)	Float Inverse	0	32
1073	Stream 4 Analog Range (PPB)	Float Inverse	0	32
1075	Stream 5 Analog Range (PPB)	Float Inverse	0	32
1077	Stream 6 Analog Range (PPB)	Float Inverse	0	32
1079	Stream 1 HI Alarm Enable, 1=ON	Byte	0	8
1079	Stream 2 HI Alarm Enable, 1=ON	Byte	8	8
1080	Stream 3 HI Alarm Enable, 1=ON	Byte	0	8
1080	Stream 4 HI Alarm Enable, 1=ON	Byte	8	8
1081	Stream 5 HI Alarm Enable, 1=ON	Byte	0	8
1081	Stream 6 HI Alarm Enable, 1=ON	Byte	8	8

<b>Decimal Address</b>	<b>Description</b>	<b>Register Type</b>	<b>Start Bit</b>	<b># Bits</b>
1082	Stream 1 HI-HI Alarm Enable, 1=ON	Byte	0	8
1082	Stream 2 HI-HI Alarm Enable, 1=ON	Byte	8	8
1083	Stream 3 HI-HI Alarm Enable, 1=ON	Byte	0	8
1083	Stream 4 HI-HI Alarm Enable, 1=ON	Byte	8	8
1084	Stream 5 HI-HI Alarm Enable, 1=ON	Byte	0	8
1084	Stream 6 HI-HI Alarm Enable, 1=ON	Byte	8	8
1085	Alarm Latch Mode, 1= Latching, 0= Non-Latching	Byte	0	8

This page intentionally left blank.

# 9. MAINTENANCE AND ADJUSTMENTS



**CAUTION**  
RISK OF ELECTRICAL SHOCK. THE OPERATIONS  
OUTLINED IN THIS CHAPTER ARE TO BE PERFORMED BY  
QUALIFIED MAINTENANCE PERSONNEL ONLY!

## 9.1. Maintenance Schedule

Table 9-1 below outlines the suggested maintenance procedures and intervals for ensuring the M465L continues to operate accurately and reliably. These intervals are based on continuous (24 hours a day – 7 days a week) operation. These intervals may be lengthened for intermittent operation.

**Table 9-1: Maintenance Schedule**

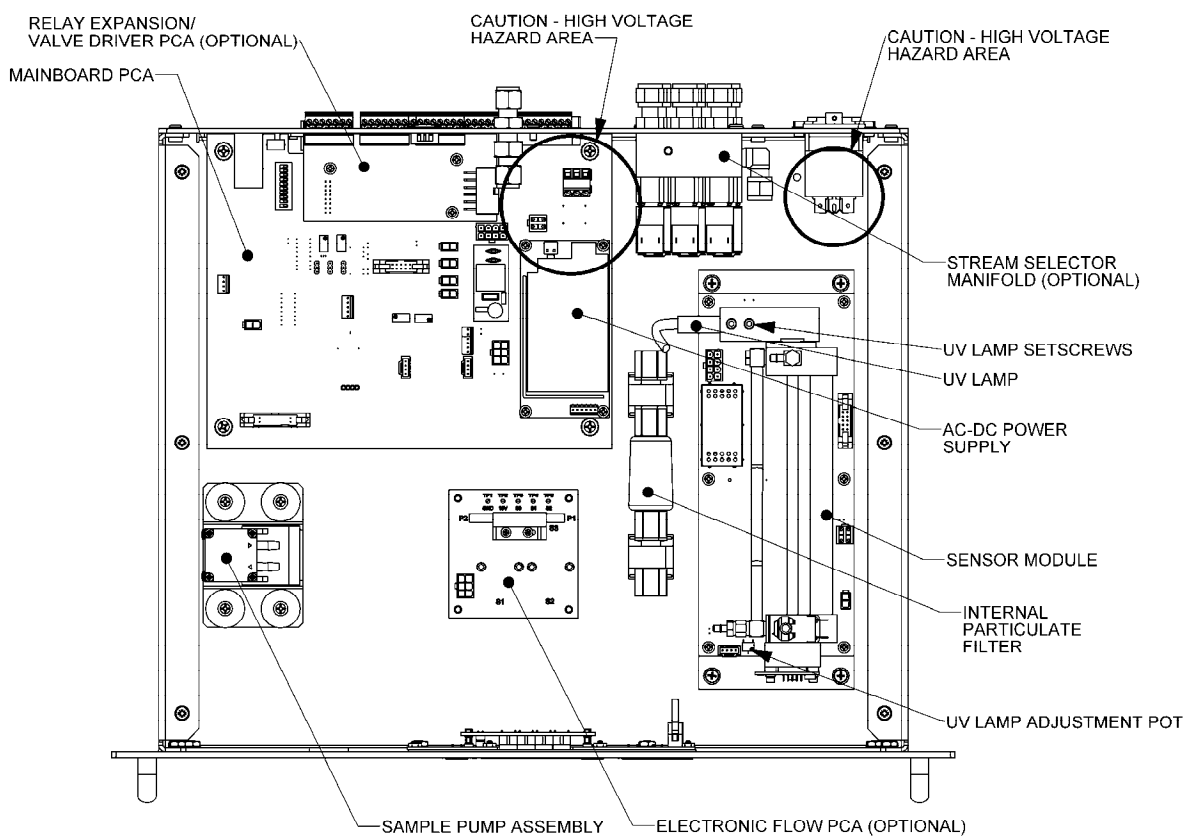
Maintenance Item	Recommended Interval	Section
Replace internal particulate filter	6 months <sup>*1</sup>	9.3
Adjust UV lamp	As Indicated by ‘Check Lamp’ LED or status output	9.4
Replace lamp	As required; when adjustment can no longer be performed.	9.5
Replace sample pump	2 years	9.6
Replace Sensor Module Valve	2 years	9.7
<sup>*1</sup> When external sample line pre-filters are used. If pre-filters are not used, internal sample filter should be replaced every month.		

## 9.2. Instrument Layout

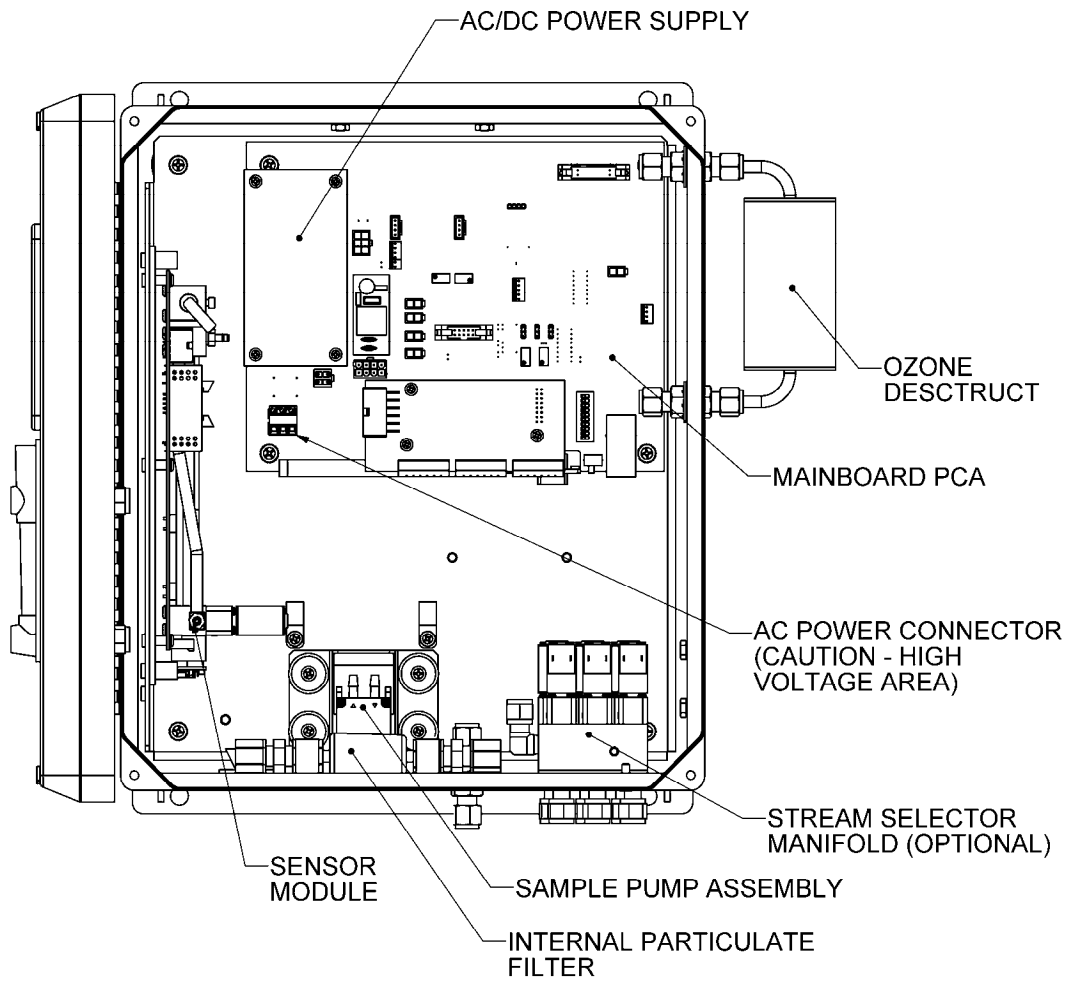


Figure 9-1 and Figure 9-2 below shows the internal layout of the M465L. These figures will be referenced in the procedures that follow.

Note the caution areas where high voltage (line voltage) may be present when power is connected to the instrument.



**Figure 9-1: Instrument Layout, Rack Mount Configuration**



**Figure 9-2: Instrument Layout, NEMA Configuration**

## 9.3. Replacing Internal Particulate Filter

1. Disconnect power from the M465L.
2. Remove the six screws and the top cover (Rack Mount Configuration) or open front panel (NEMA Configuration.)
3. Locate the filter (see Figure 9-1 or Figure 9-2 above.) Un-strap the filter from the two plastic hold-down clamps. Note the arrow on the filter showing flow direction.
4. Loosen the two nuts holding the filter into the two union fittings.
5. Install the nuts on the new filter. Hand-tighten until snug, do not use tools.
6. Perform steps 1 through 3 in reverse order to complete installation.

## 9.4. UV Lamp Adjustment



1. Instrument should be running and warmed up for at least 20 minutes.
2. With instrument running, remove the six screws and the top cover.
3. Navigate the front panel menu to VIEW menu and scroll to REF display and press **ENT**. At this point there should be a scrolling display similar to “REF = XXXX MV.” See Section 7.2 for details on menu navigation.
4. Locate the UV Detector adjustment pot on the forward end of the sensor module (see Figure 9-1 or Figure 9-2 above.)
5. While observing the REF value on the display, slowly turn the pot to adjust the value. The target adjustment range is as high as possible within the range of **800 – 1150 mV**.
6. If the required adjustment cannot be achieved by adjusting the UV Detector pot alone, then additional adjustment can be made by loosening the two UV lamp setscrews on the UV lamp housing (see Figure 9-1 or Figure 9-2) and rotating the lamp. Rotate the lamp very slowly while observing the REF value on the display. Make sure the lamp does not pull out and remains seated in the housing while it is being rotated. Re-tighten the two setscrews when a desired point has been reached.
7. If necessary, additional “fine tuning” can now be done with the UV Detector adjustment pot per step 5.
8. Re-Install instrument cover and observe REF value on display for a couple minutes to verify it does not drift out of the adjustment range.

## 9.5. UV Lamp Replacement



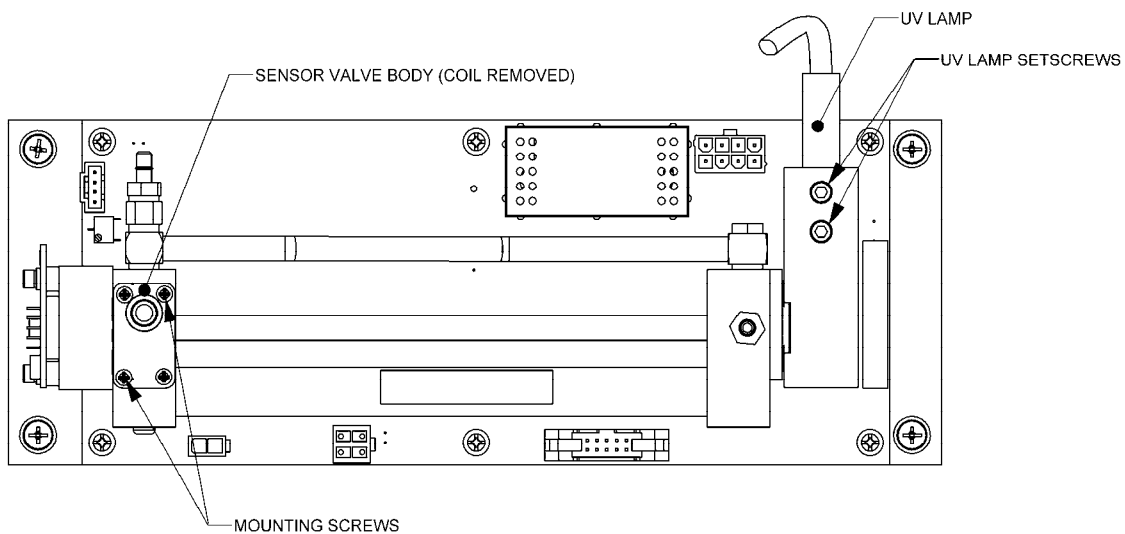
1. Disconnect power from the M465L.
2. Remove the six screws and the top cover (Rack Mount Configuration) or open front panel (NEMA Configuration.)
3. Loosen the two UV lamp setscrews on the UV lamp housing (see Figure 9-1 or Figure 9-2 above.)
4. Unplug the lamp power cord from the connector labeled P1 on the sensor module.
5. Loosen the four slotted captive screws attaching the sensor module to the chassis.
6. Carefully slide the lamp out of housing. The sensor module may need to be raised slightly to completely remove the lamp.
7. Install the new lamp, seating it in the lamp housing until it stops.
8. Re-attach the sensor module captive screws to the chassis.
9. Re-tighten the two UV lamp setscrews.
10. Plug the lamp power cord into P1 on the sensor module.
11. Reconnect power to the instrument and turn on power switch. Let instrument warm up for at least 20 minutes.
12. Perform UV lamp adjustment procedure per Section 9.4.

## 9.6. Sample Pump Replacement

1. Disconnect power from the M465L.
2. Remove the six screws and the top cover (Rack Mount Configuration) or open front panel (NEMA Configuration.)
3. Locate sample pump assembly (See Figure 9-1.)
4. Cut off the clamps holding the tubing to the pump nipples and remove tubing. Note which tubing is connected to inlet and outlet.
5. Unplug the pump power connector from the mainboard PCA at connector J12.
6. Remove the four screws attaching the sample pump assembly to the chassis.
7. Turn over pump assembly and remove the two screws holding the sheet-metal base to the pump.
8. Install the base on the new pump.
9. Install new pump assembly in chassis.
10. Reconnect tubing, note that outlet fitting of pump should be connected to tubing routed to the 'Exhaust' fitting on rear panel.
11. Re-install new tubing clamps or cable-ties to secure tubing connections.

## 9.7. Sensor Valve Replacement

1. Disconnect power from the M465L.
2. Remove the six screws and the top cover (Rack Mount Configuration) or open front panel (NEMA Configuration.)
3. Locate sensor module assembly (See Figure 9-1.)
4. Unplug the two-pin valve connector from the sensor PCA.
5. Remove the silver retainer clip from the top of the sensor valve. A pair of pliers may be used to slide off the retainer clip.
6. The valve coil can now be removed by sliding upwards.
7. Remove the two (2) mounting screws using a #2 Phillips screwdriver. See Figure 9-3.  
Note that there are four screw heads visible on the top of the valve body, only two (2) of these should be removed.
8. Remove valve body from sensor manifold.
9. Clean any residue or dirt off the surface of the manifold using a lint-free cloth and distilled or DI water.
10. Install the new valve by reversing steps 1-7. Note the proper orientation of the new valve as shown in Figure 9-3.



**Figure 9-3: Sensor Detail**

## 9.8. Water Drop-Out Filter (Option) Maintenance

Located externally on the right side of the enclosure, the Water Drop-Out Filter (Section 4.1.1.2) should be checked periodically for water build-up and drained. To drain this filter:

1. Disconnect the ozone supply line from the instrument.
2. Shut off flow to the instrument using the needle valve on the front panel.
3. Remove cap from the fitting located on the bottom of the filter and allow it to drain.
4. Replace cap and adjust flow to instrument.

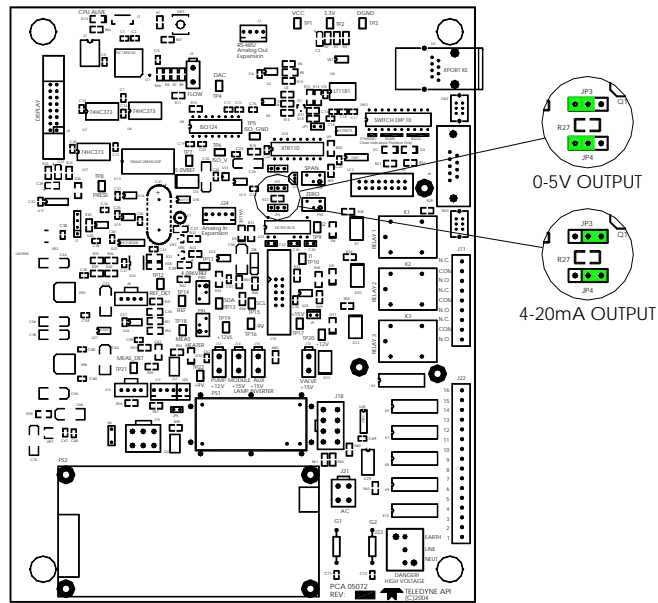
Replacement of the particulate filter, a Teflon coalescing membrane should be rarely required. However, if it does become fouled, possibly indicated by a significant reduction in the gas pressure measured in the O<sub>3</sub> cell, which would trigger a warning in the instrument, replace it as follows:

1. Remove the orange cap from the top of the water drop-out filter.
2. Located the membrane on the underside of the cap assembly and replace it.
3. Tightly secure the orange cap back onto the water drop-out filter.

## 9.9. Configuring the Analog Output

The analog output can be configured for either 0-5V DC or 4-20mA operation. To change or verify the configuration of the analog output:

1. Disconnect power from the M465L.
2. Remove the six screws and the top cover (Rack Mount Configuration) or open front panel (NEMA Configuration.)
3. Locate the Mainboard PCA (see Figure 9-1 or Figure 9-2.)
4. Set the desired operation as shown in Figure 9-4.
5. Re-Install the top cover or re-secure the front panel (NEMA Configuration.)



**Figure 9-4: Mainboard – Analog Output Configuration**

## 9.10. Cleaning Exterior Surfaces of the M465L

If necessary, the front panel mask and keyboard of the M465L can be cleaned with a damp cloth. Do not attempt to clean any of the other surfaces of the instrument. Do not submerge any part of the instrument in water or cleaning solution.

This page intentionally left blank.

# 10. TROUBLESHOOTING



## CAUTION

RISK OF ELECTRICAL SHOCK. THE OPERATIONS OUTLINED IN THIS CHAPTER ARE TO BE PERFORMED BY QUALIFIED MAINTENANCE PERSONNEL ONLY!

## 10.1. Reference Drawings

The drawings contained in this section are for general reference and may be useful when performing certain troubleshooting activities.

### 10.1.1. Pneumatic Diagram

Figure 10-1 below is a pneumatic diagram that can be referenced when performing troubleshooting on the monitor. Note that certain items, such as the Stream Selector and Electronic Flowmeter are optional and will not be present in all M465L monitors.

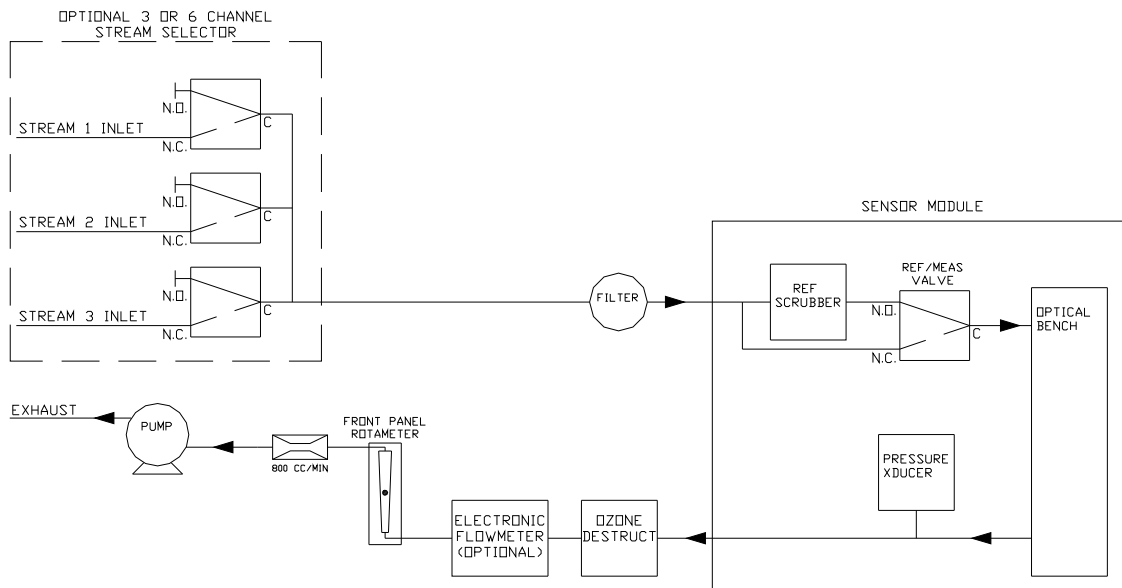


Figure 10-1: Pneumatic Diagram, 3 Stream Configuration

## 10.1.2. Interconnect Diagram

Figure 10-2 below details the electrical connections between the various electronic modules in the M465L.

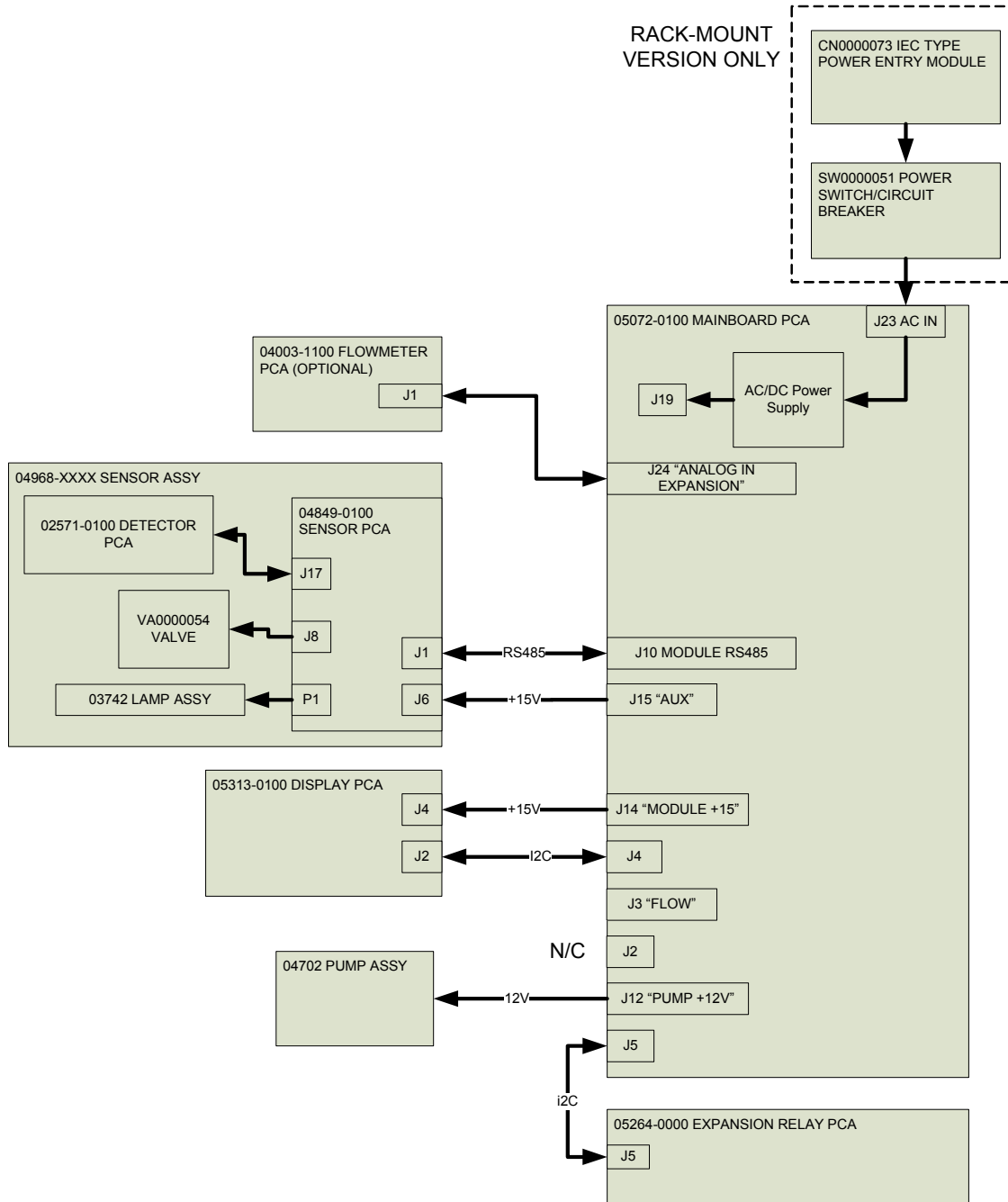


Figure 10-2: Interconnect Diagram

## 10.2. Troubleshooting Using Front Panel Status LED's or Status Outputs

The M465L has 4 front-panel status LED's that reflect the current operating status of the monitor, and indicate fault conditions. There are also four relay Status Outputs on the rear panel (or internally in the NEMA configuration) that also reflect the state of these status LED's. See Section 4.2.3 for more information on the Status Outputs.

The Status LED's are categorized into Critical and Non-Critical warnings. Critical warnings are those that would normally require immediately removing the monitor from service and repairing it. Non-critical warnings are those that indicate some maintenance would be useful, but not immediately required.

**Table 10-1: Status LED/Output Definitions**

Status Output #	Status LED Label	Normal Operating State	Triggers	Critical Warning?
1	Sensor OK	On	<ul style="list-style-type: none"> <li>• No bench communications</li> <li>• Reference &lt; 125.0 mV</li> <li>• Reference &gt; 1230.0 mV</li> </ul>	Yes
2	Invalid Reading	Off	<ul style="list-style-type: none"> <li>• O<sub>3</sub> Concentration &lt; -10.0 PPB</li> <li>• O<sub>3</sub> Concentration &gt; F.S. Range</li> </ul>	No
3	Check Lamp	Off	<ul style="list-style-type: none"> <li>• Reference &lt; 250.0 mV</li> </ul>	No
4	Pneumatic Error	Off	<ul style="list-style-type: none"> <li>• Pressure &lt; 9.0 psia</li> <li>• Pressure &gt; 14.9 psia</li> <li>• Flow &lt; 640 cc/min</li> <li>• Flow &gt; 960 cc/min</li> </ul>	No

### 10.2.1. Sensor OK

The Sensor OK LED indicates the status of the O<sub>3</sub> sensor module in the monitor. The normal state of this LED (or Status Output) is On. If this LED remains off after the normal 20 minute warm-up period, then a failure has occurred and the monitor should be removed from service and repaired.

The most common cause of this warning is a failure of the UV Lamp. A UV Lamp Adjustment (See Section 9.4) should be attempted. If the UV Lamp cannot be adjusted to meet the specified values, then a UV Lamp Replacement should be performed (See Section 9.5.)

This warning can also be caused by a communications error with the sensor module. Inspect the two cables between the Mainboard PCA and Sensor Module for loose or intermittent connections (See Section 9.2 for monitor layout.) If no cable problem can be found, then the Sensor Module should be replaced.

### 10.2.2. Invalid Reading

The Invalid Reading LED indicates that the instrument is reading a value that cannot be represented properly on the analog output. Since the analog output is limited to 0-5V (or 4-20mA,) it cannot properly represent negative values, or values in excess of the full-scale range.

If the monitor is consistently reading negative values, then a zero calibration should be performed, see Section 7.2.3.4.

If the monitor is consistently reading values in excess of the full-scale range, then the range value should be adjusted higher. See Section 7.2.7 for details on setting the range value.

### 10.2.3. Check Lamp

The Check Lamp LED indicates that the UV Lamp intensity has dropped below 250mV, a level where UV Lamp Adjustment (See Section 9.4) should be made at the next convenient opportunity. Note that this is a non-critical warning and immediate service is not required. However if the UV Lamp intensity drops below 125mV, then the Sensor OK LED will also turn off, indicating that the monitor must be immediately serviced or taken off-line.

### 10.2.4. Pneumatic Error

The Pneumatic Error LED indicates that one of the pneumatic parameters, flow or pressure, has gone outside of normal ranges. Note that this is a non-critical warning and immediate service is not required. However if the Sensor OK LED turns off then the monitor must be immediately serviced or taken off line.

The first step in troubleshooting a Pneumatic Error is determining which parameter has caused the warning. At the monitor front panel, navigate to the VIEW menu (See Section

7.2.4.) Examine the Flow and Pressure values and compare them to the limits described in Table 10-1 and take appropriate action as described below.

#### 10.2.4.1. Pressure Too High

The monitor inlet is being pressurized. The monitor inlet should be allowed to sample gas at ambient pressure. Disconnect all sample lines from the monitor and read the pressure again. If the value then drops to within the acceptable range, then one of the sample lines is at elevated pressure.

If the inlet is being pressurized, then the design of the sample system should be reviewed and corrected. Contact Teledyne API customer service for assistance.

#### 10.2.4.2. Pressure Too Low

Something may be restricting the flow through the monitor, causing the sample pump to pull a vacuum on the sensor module. First, unplug the sample pump power plug on the Mainboard PCA and observe the pressure reading. If the pressure reading is still too low, then likely there is a problem with the pressure sensor on the Sensor Module and the Sensor Module should be replaced. Next reconnect the pump and disconnect all sample lines from the monitor and see if the pressure increases to normal levels. If it does, then the problem is somewhere in the sampling system external to the monitor. If the pressure is still below the limit with the sample lines removed, then there is a restriction in the pneumatics of the monitor upstream of the sensor assembly. The most likely cause is a plugged particulate filter. Disconnect the outlet fitting on the sample filter and observe the pressure. If it returns to normal levels then the restriction is in the particulate filter or inlet manifold assembly (multi-stream configurations only.) Replace particulate filter per Section 9.3.

This page intentionally left blank.

# 11. CALIBRATION

---



## CAUTION

RISK OF ELECTRICAL SHOCK. THE OPERATIONS OUTLINED IN THE FOLLOWING SECTIONS OF THIS CHAPTER ARE TO BE PERFORMED BY QUALIFIED MAINTENANCE PERSONNEL ONLY!

### 11.1. Factory Calibration

The Model 465 is calibrated to NIST traceable standards on the 0-1 ppm range prior to shipment. A calibration certificate for your instrument can be purchased from Teledyne API if required. Teledyne API also recommends that the Model 465 be re-calibrated once a year. Teledyne API can provide NIST traceable calibration services at our factory or on-site. Please contact our Customer Service department for details on these services.

### 11.2. Zero Calibration

A zero calibration can be easily performed in the field, and Teledyne API recommends that this be done at least annually. See Section 7.2.3.4 for details on performing a zero calibration.

This page intentionally left blank.

# 12. SPARE PARTS

---

This section provides the names and part numbers of the spare parts for the M465L rack mount units and for the NEMA units.

## 12.1. M465L Rack Mount Spare Parts List

PARTNUMBER	DESCRIPTION
025710100	PCA, UV DETECTOR PREAMP, M454/M460
036750000	AKIT, ELEMENTS, 47MM, 30 MICRON (10 PCS)
037420000	ASSY, UV LAMP (BIR) M452/454/460X/465L *
040031200	PCA, FLOW SENSOR, M465
046170000	ABSORPTION TUBE, M460L
046740000	ASSY, PUMP, 12VDC, M460M/M700E
048490100	PCA, O3 BENCH, M460L/M465L
050720300	PCA, MAINBOARD, M465L, CE
052640000	PCA, RELAY/VALVE EXPANSION, M460/M465L
053010000	AKIT, EXP KIT, CARULITE 200
053130300	PCA, FRONT, MULTI CHL, M465L, CE
053130400	PCA, FRONT PANEL, SNGL CHL, M465, CE
053200000	PCA, FRONT PANEL DAUGHTER BOARD, M465L
055090000	MANUAL, OPERATORS, M465L
059350000	ASSY, FLOWMETER W/O VALVE, M465L
061760100	ASSY, FLOWMETER, M465L/M
062310000	AKIT, OPTION, PRE-FILTERS, 1 STREAM, M46
062680000	ASSY, ZERO SCRUBBER, OZONE
DR0000006	DRYER, 24", 1/4" SS FITTINGS
FL0000033	DFU, KYNAR, 1/4" TUBE
FM0000004	FLOWMETER (KB)
HW0000120	SHOCKMOUNT, GROMMET ISOLATOR
KIT000267	AKIT, M46XL PRE-FILTERS (FL37-25 pcs)
OP0000031	WINDOW, QUARTZ, 1/2"DIA, .063" THICK (KB)
OR0000039	ORING, 2-012V
OR0000050	ORING, 2-014V

PARTNUMBER	DESCRIPTION
OR0000098	ORING, 2-108S
OR0000099	ORING, 2-129, CV-75 COMPOUND
OR0000104	ORING, 5-125V
PS0000042	PS, 60W SWITCHING, 2X4, 15V
SW0000051	SWITCH, POWER CIRC BREAK VDE/CE, w/RG(KB
VA0000054	MANIFOLD, 3-WAY VALVE, PEEK/VITON
WR0000008	POWER CORD, 10A

05919G – M465L, SPL, (DCN 5123) 10/01/08

## 12.2. M465L NEMA Spare Parts List

PARTNUMBER	DESCRIPTION
025710100	PCA, UV DETECTOR PREAMP, M454/M460
036280000	ASSY, WATER DROP OUT FILTER, PFA, M450
036750000	AKIT, ELEMENTS, 47MM, 30 MICRON (10 PCS)
037420000	ASSY, UV LAMP (BIR) M452/454/460X/465L *
040031200	PCA, FLOW SENSOR, M465
046170000	ABSORPTION TUBE, M460L
046740000	ASSY, PUMP, 12VDC, M460M/M700E
048490100	PCA, O3 BENCH, M460L/M465L
048990300	ASSY, HI-CON O3 SCRUBBER, CH71
049680100	ASSY, SENSOR, LO-CONC, M460L/M465L
050300000	ASSY, REF SCRUBBER, HI-CONC, M460L/M465L
050720300	PCA, MAINBOARD, M465L, CE
052640000	PCA, RELAY/VALVE EXPANSION, M460/M465L
053010000	AKIT, EXP KIT, CARULITE 200
053130300	PCA, FRONT, MULTI CHL, M465L, CE
053130400	PCA, FRONT PANEL, SNGL CHL, M465, CE
053200000	PCA, FRONT PANEL DAUGHTER BOARD, M465L
055090000	MANUAL, OPERATORS, M465L
058400001	ASSY, REF SCRUBBER, LO-CONC, M460L/M465L
061760100	ASSY, FLOWMETER, M465L/M
062310000	AKIT, OPTION, PRE-FILTERS, 1 STREAM, M46
062680000	ASSY, ZERO SCRUBBER, OZONE

<b>PARTNUMBER</b>	<b>DESCRIPTION</b>
CN0000350	CONNECTOR, 16 PIN, W/SCREW FLANGE
DR0000006	DRYER, 24", 1/4" SS FITTINGS
FL0000033	DFU, KYNAR, 1/4" TUBE
HW0000120	SHOCKMOUNT, GROMMET ISOLATOR
KIT000267	AKIT, M46XL PRE-FILTERS (FL37-25 pcs)
OP0000031	WINDOW, QUARTZ, 1/2"DIA, .063" THICK (KB
OR0000039	ORING, 2-012V
OR0000050	ORING, 2-014V
OR0000098	ORING, 2-108S
OR0000099	ORING, 2-129, CV-75 COMPOUND
OR0000104	ORING, 5-125V
PS0000042	PS, 60W SWITCHING, 2X4, 15V
VA0000054	MANIFOLD, 3-WAY VALVE, PEEK/VITON

05910H – M465L, SPL, (DCN 5123) 10/01/08

This page intentionally left blank.

# INDEX

- Accuracy
  - sample filtration, 19
  - sampling lines, 19
  - Specifications, 9
- Alarm Relays
  - Specifications, 10
- Analog Output
  - Specifications, 10
- asurement Units
  - Specifications, 9
- Cleanliness in pneumatic system
  - importance of, 19
- Connection
  - Ethernet, 27
  - RS232, 27
  - RS485, 27
- Diagnostic LEDs, 23
- Dimensions
  - Specifications, 10
- Environmental Conditions
  - Specifications, 10
- Humid Environments, 19
- Humidity Range
  - Specifications, 9
- Isolated Analog Output
  - Specifications, 10
- Lower Detectable Limit
  - Specifications, 9
- Markings, 11
- Maximum Operating Altitude
  - Specifications, 10
- Multi-Stream Specifications:, 11
- Noise
  - Specifications, 9
- Option
  - Flowmeter, 29
  - Permeation Gas Dryer, 21, 30
  - Rack Mount Slides, 29
  - Sample Conditioner, 21, 29
  - Sample Inlet Filters, 29
  - Stream Selector, 29
- Permeation Gas Dryer, 21
- Power
  - Specifications, 10
- Ranges
  - Specifications, 9
- Response Time
  - Specifications, 9
- ument Status Outputs
  - Specifications, 10
- Sample Conditioner, 21
- Sample Filtration Accuracy, 19
- Sample Flow Rate
  - Specifications, 9
- Sample gas connection
  - multi-stream, 18
  - single stream, 18
- Spare Parts
  - for NEMA units, 79
  - for rack mount units, 78
- Startup
  - initial behavior, 15
- Status Relay
  - Specifications, 10
- Temperature Range
  - Specifications, 9
- UV light absorption, 13
- Weight
  - Specifications, 10