



TELEDYNE
ADVANCED POLLUTION INSTRUMENTATION
A Teledyne Technologies Company

MANUAL ADDENDUM

MODEL M201E

AMMONIA ANALYZER

(For use with the M200E Operators Manual, P/N 04410)

**TELEDYNE ADVANCED POLLUTION INSTRUMENTATION
(TELEDYNE-API)
9480 CARROLL PARK DRIVE
SAN DIEGO, CA 92121-5201**

TOLL-FREE:	800-324-5190
FAX:	858-657-9816
TEL:	858-657-9800
E-MAIL:	api-sales@teledyne.com
WEB SITE:	www.teledyne-api.com

ABOUT THIS MANUAL

This manual is an addendum that supplements the M200E NOx Analyzer manual, p/n 04410; it includes document(s) as listed below.

Part No.	Name/Description
06185H	M201E Spare Parts List (in Section 6.0) Note: Please refer to our Website or Sales for more recent updates.

NOTE

We recommend that this manual and the M200E manual be read in their entirety before any attempt is made to operate the instrument.

REVISION HISTORY

M201E, MANUAL ADDENDUM, PN 05206

14 May 2010				
Document	Part #	To Rev	DCN	Change Summary
Title, main body/content	05206	G	5731	Added Caution message (Section 1) to report the detection of ozone ASAP. Added note (Section 4) to follow M200E maintenance and repair schedule
17 Nov 2009, Rev F, DCN5588				
Document	Part #	To Rev	DCN	Change Summary
Title, main body/content	05206	F	5588	<ul style="list-style-type: none"> Section 4: Add thermocouple replacement instructions Section 5: Reorient and relabel catalytic cartridge illustration and move to Section 4. Replace pneumatic diagram figures with updated diagrams (<i>ref PN 05334, DCR 6688, moved ozone destruct from after vacuum manifold to before</i>), and move from Section 5 to Section 1.
Spare Parts List	06185	H	5494	Was at Rev E in last update of this manual.

This page intentionally left blank.

SAFETY MESSAGES

Your safety and the safety of others is very important. We have provided many safety messages throughout this manual; please read these messages carefully.

A safety message alerts you to potential hazards that could hurt you or others. Safety messages are associated with a safety alert symbol. These symbols are found in both the M200E and M201E manuals and are also located inside the instrument. The definition of these symbols is described below:



GENERAL WARNING/CAUTION: Refer to the instructions for details on the specific danger.



CAUTION: Hot Surface Warning



WARNING: Electrical Shock Hazard



Technician Symbol: All operations marked with this symbol are to be performed by qualified maintenance personnel only.



Electrical Ground: This symbol inside the instrument marks the central safety grounding point for the instrument.



CAUTION The analyzer should only be used for the purpose and in the manner described in this manual.

If you use the analyzer in a manner other than that for which it was intended, unpredictable behavior could ensue with possible hazardous consequences.

This page intentionally left blank.

TABLE OF CONTENTS

1.0	M201E AMMONIA ANALYZER	7
1.1	Theory of Operation	10
1.1.1	Minimizing PMT Drift	11
1.1.2	Purging the Reaction Cell	12
1.2	Special Considerations For Ammonia Measurement	12
1.3	Sample Filtration	13
1.4	M201E Analyzer Specifications	14
2.0	CALIBRATION PROCEDURE	15
2.1	Zeroing The Analyzer	16
2.2	Spanning The Analyzer With Nitric Oxide Gas	17
2.3	Spanning The Analyzer With Ammonia Gas	20
3.0	CONFIGURABLE ANALOG OUTPUT OVERVIEW	25
3.1	Analog Output - Electronic Configuration	27
3.2	Analog Output Signal Type and Range Selection	28
3.3	Selecting Auto Or Manual Analog Output Calibration	29
3.4	Manually Calibrating Analog Output Signal Levels	32
3.5	Analog Output Recorder Offset Adjustment	34
4.0	MAINTENANCE SCHEDULE	35
4.1	M501NH Maintenance	35
4.2	Replacing the Catalytic Cartridge	36
4.3	Replacing the Thermocouple	37
4.4	AutoZero Flow Check	39
5.0	ALARMS AND CAUTIONS	41
5.1	Alarm	41
5.2	Caution	41
6.0	M201E SPARE PARTS LIST	43
7.0	CALCULATING MOLY CONVERTER EFFICIENCIES	47
7.1	Purpose:	47
7.2	TOOLS:	47
7.3	PARTS:	47
7.4	PROCEDURE:	47

LIST OF FIGURES

Figure 1-1.	M201E Pneumatic Connection Diagram with External Calibrator Option (ECO)	8
Figure 1-2.	M201E and M501NH Pneumatic Flow	9
Figure 1-3.	M201E and M501NH with Zero and Span Valve Options Pneumatic Flow	10
Figure 3-1.	Analog Output Connector	25
Figure 3-2.	Analog Output Signal Type	28
Figure 3-3.	Auto Or Manual Analog Output Calibration	30
Figure 3-4.	Analog Output Group Calibration	31
Figure 3-5.	Setup For Calibrating Analog Output Signal Levels	32

Figure 3-6. Analog Output Manual Calibration.....	33
Figure 3-7. Analog Output Recorder Offset Calibration	34
Figure 4-1. Catalytic Cartridge	36
Figure 4-2. Thermocouple Location	37
Figure 5-1. M201E Functional Block Diagram	42

LIST OF TABLES

Table 1-1. M201E Operating Specifications	14
Table 2-1. Zero Calibration Procedure – Zero Gas Through the SAMPLE Port	16
Table 2-2. Zero Calibration Procedure - Zero Gas Through ZERO Port	17
Table 2-3. NO Calibration Procedure – NO Gas Through the SAMPLE Port	18
Table 2-4. NO Calibration Procedure - NO Gas through the SPAN Port.....	19
Table 2-5. Confirming Ammonia Converter Efficiency	21
Table 2-6. NH3 Calibration Procedure – NH3 Gas Through The SAMPLE Port.....	22
Table 2-7. NH3 Calibration Procedure – NH3 Gas through the SPAN Port.....	23
Table 3-1. Analog Output Data Default Settings.....	25
Table 3-2. Analog Output Pin-Outs	26
Table 3-3. Analog Output Voltage Range Min/Max	27
Table 3-4. Analog Output Current Loop Min/Max	27
Table 3-5. ZERO/SPAN Analog Output Signal Calibration Tolerances.....	32
Table 4-1. Preventative Maintenance Schedule.....	35
Table 4-2. M501NH Converter Rebuild Parts List.....	36
Table 4-3. Analyzer Flow Check	39

1.0 M201E AMMONIA ANALYZER

This manual is to be used in conjunction with the M200E NO_x Analyzer manual, p/n 04410 supplied with this instrument. It is important that you familiarize yourself with the workings of the NO_x analyzer before proceeding with NH₃ measurements.

	<p style="text-align: center;">CAUTION!</p> <p>If the presence of ozone is detected at any time, call Teledyne API Customer Service as soon as possible:</p> <p style="text-align: center;">800-324-5190 or email: api-customerservice@teledyne.com</p>
---	--

The M201E ammonia analyzer consists of a modified M200E nitrogen oxide analyzer and an M501NH ammonia converter. The analyzer measures the following individual gas concentrations: TN_x (NH₃ and NO_x), NO_x (NO and NO₂) and NO in the sample gas.

- The ammonia concentration is calculated by subtracting the NO_x reading from the TN_x measurement.
- The nitrogen dioxide concentration is calculated by subtracting the NO reading from the NO_x measurement.

The instrument comes in three pneumatic configurations:

- The M201E with External Calibrator Option (ECO) is shown in Figure 1-1.
- The basic system is shown in Figure 1-2.
- The M201E with Zero/Span valves is shown in Figure 1-3.

Note: For an M201E analyzer with Zero/Span option you must connect the umbilical cord P/N 02255 between the analyzer and the external M501NH converter assembly.

If the analyzer is purchased without the Zero/Span option then the zero and span calibration gases must be individually applied to the sample port. Remember, the gases must be clean/dry and supplied at ambient pressure.

<p style="text-align: center;">CAUTION</p> <p>Do not pressurize the Sample/Span/Zero port above ambient</p>



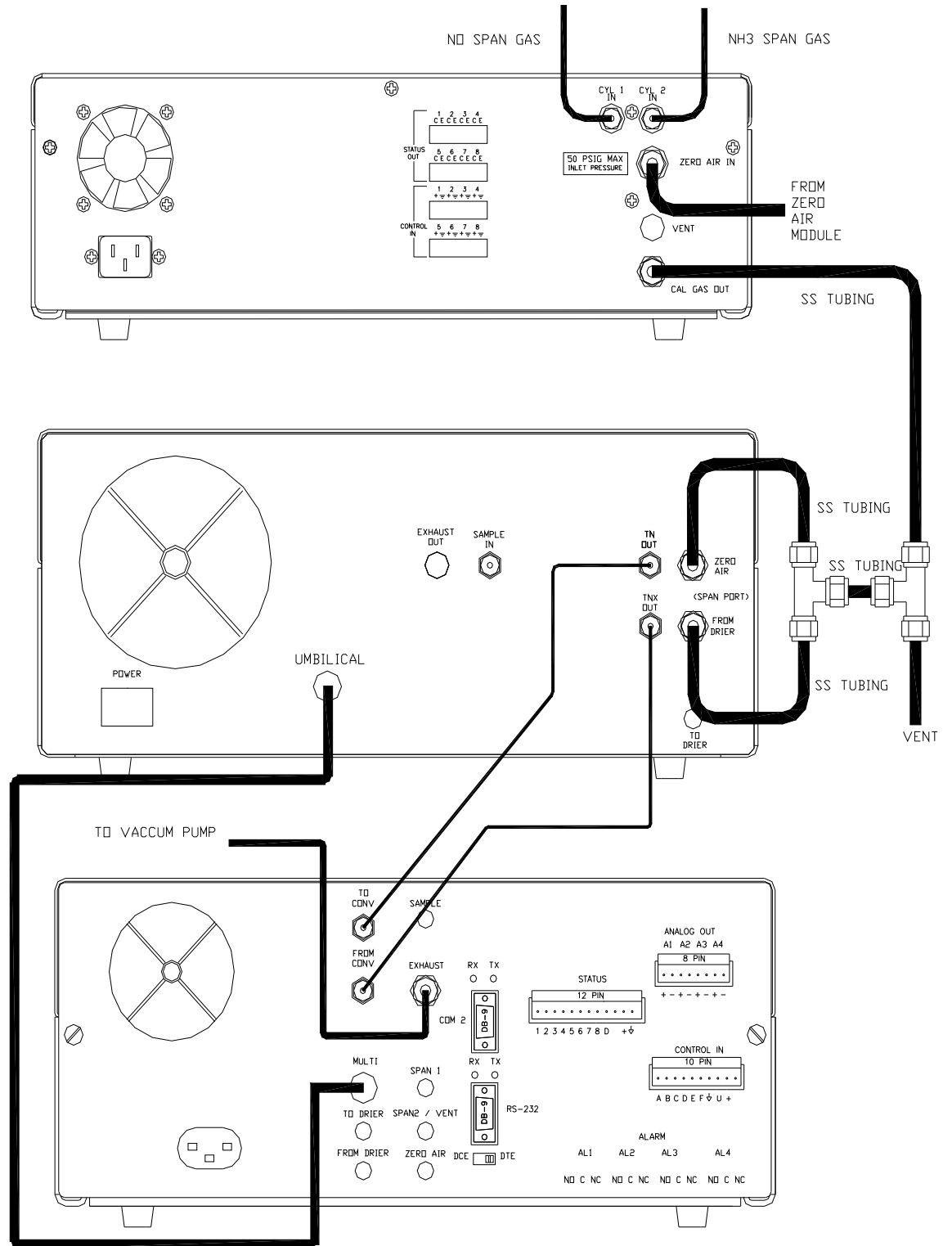

Figure 1-1. M201E Pneumatic Connection Diagram with External Calibrator Option (ECO)

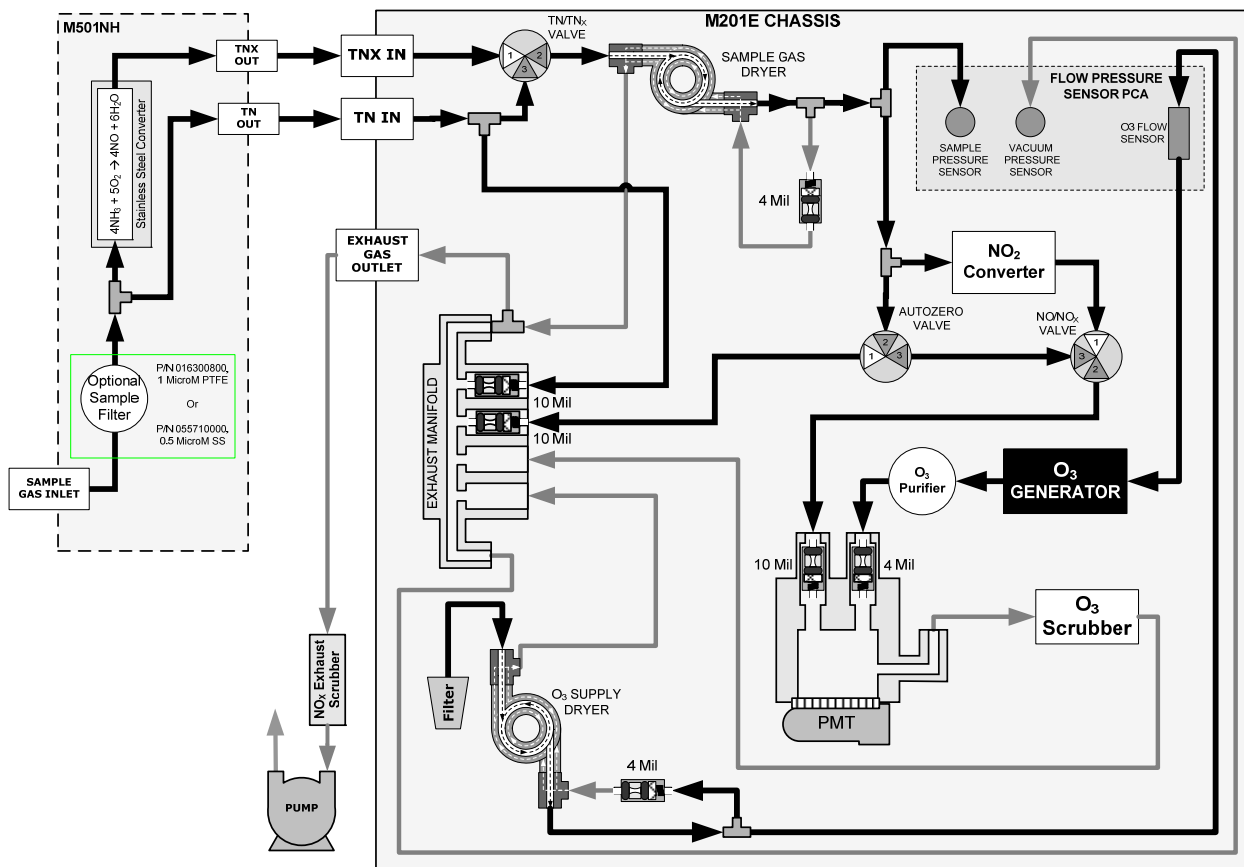

Figure 1-2. M201E and M501NH Pneumatic Flow

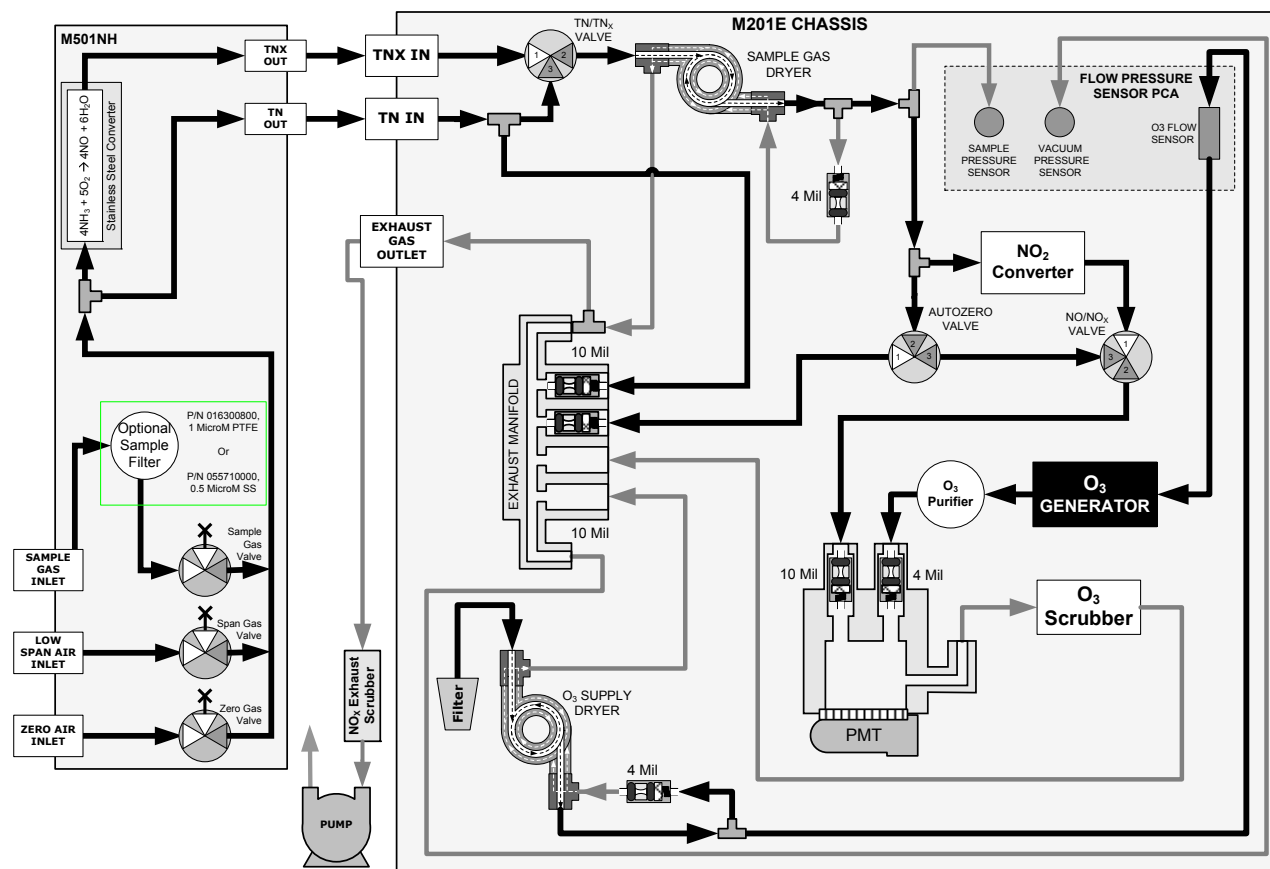
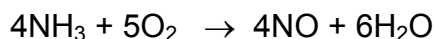

Figure 1-3. M201E and M501NH with Zero and Span Valve Options Pneumatic Flow

1.1 THEORY OF OPERATION

The Teledyne-API Model M201E analyzer measures ammonia by oxidizing it to nitric oxide by the following reaction:



The resulting nitric oxide is then measured by the chemiluminescent reaction with ozone. Consult Section 10.1 in the M200E manual (provided with this instrument) for more details on the nitric oxide measurement.

The analyzer uses two converters to oxidize the different sample gases. A high temperature catalytic converter, the M501NH, converts NH₃ and NO_x into NO creating the TN_x channel. A second converter, housed inside the M201E analyzer and consisting of heated molybdenum, converts all of the NO_x in the sample to NO producing the NO_x channel. The nitric oxide channel is measured while bypassing both the M501NH and molybdenum converter. A Nafion® drier operated in reflux mode, is installed prior to the molybdenum converter and the AutoZero valve. The drier removes ammonia and water from the switched stream. The ammonia would have otherwise been converted by the molybdenum

and registered as NO_x. This location provides the drier with continuous flow, thereby allowing it to stabilize faster.

Note: Due to the Nafion® drier, the analyzer has a maximum ammonia range of 2.0 PPM.

The calculated gas concentrations, ammonia and nitrogen dioxide, are computed from the differences between the measured channels, as outlined in the following equations:

NO (Nitric Oxide) Concentration = Measured

TN_x (Total Nitrogen) Concentration = Measured (NH₃ + NO₂ + NO)

NO_x (Total Nitrogen – Ammonia) Concentration = Measured (NO₂ + NO)

NH₃ (Ammonia) Concentration = Calculated as follows:

$$[(TN_x - NO_x) / (NH_3_CE_FACTOR1)]$$

NO₂ (Nitrogen Dioxide) Concentration = Calculated as follows:

$$[(NO_x - NO) / (NO_2_CE_FACTOR1)]$$

Note: The nitrogen dioxide efficiency factor (NO₂_CE_FACTOR1) must be calculated by conducting a GPT (gas phase titration) as described in Section 8.3.3 of the M200E manual and Section 7.0 of this manual. This value gives a good indication of how well the molybdenum is converting nitrogen dioxide into nitric oxide. In a properly functioning analyzer the value should be close to 1.0. It is recommended that the molybdenum efficiency be checked every three months.

The ammonia converter efficiency factor (NH₃_CE_FACTOR1) is discussed in more detail in Section 2.3 of this manual. The conversion efficiency of the M501NH should be checked prior to starting long term tests. Both efficiency factors can be accessed through the analyzer VARS MENU.

The actual formula for computation of the gas concentrations is more complicated than the above equations, as it includes sample, reaction cell pressure changes and averaging the PMT signal. Then the zero offset and slopes are applied to the separate channels (TN_x, NO_x, NO) to determine the concentrations. Concentration compensation occurs while the variable TP_FACTOR under the VARS MENU is switched ON. Otherwise the displayed concentration is uncompensated. It is recommended that the variable TP_FACTOR remain on at all times.

1.1.1 Minimizing PMT Drift

In order to account for PMT drift in the analyzer, the AutoZero valve switches once a minute allowing the analyzer to read zero background. The AutoZero valve directs the sample gas stream to completely bypass the reaction cell, while simultaneously filling the reaction cell with Ozone for dark noise measurement. This is then subtracted as a measurement offset from the raw PMT concentration

signal. This process improves zero baseline stability by minimizing the effect of PMT sensor drift.

1.1.2 Purging the Reaction Cell

As with many chemical reactions the conversion of ammonia in the presence of other oxides of nitrogen is complicated. It is important to note that the valve DWELL time for an AZERO measurement has a default setting of 8 seconds. Shortening this value may not allow enough time to properly purge the reaction cell of excess nitric oxide from the previous measurements.

In the molybdenum converter operating at 315°C the following significant reactions are taking place:



The M501NH ammonia converter operates at 825°C. At this high temperature, several reactions occur:

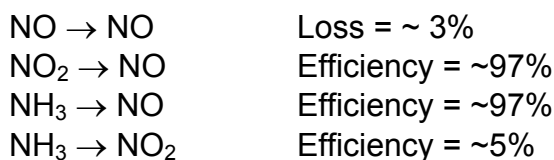

As can be seen from the above reactions, the calculation of the ammonia concentration and overall calibration of the instrument must be done carefully, if accurate ammonia concentrations are to be measured.

1.2 SPECIAL CONSIDERATIONS FOR AMMONIA MEASUREMENT

Ammonia is a difficult gas to measure due to its chemical characteristics. The gas tends to adsorb onto surfaces and diffuse into many materials. The following precautions should be observed when designing ammonia sampling systems and connecting them to the M201E analyzer:

- Do *NOT* use copper tubing or fittings designed for household plumbing.
- Use *ONLY* Chromatography grade (cleaned, passivated) stainless steel tubing.
- Use *ONLY* Glass tubing for sample inlet manifold.
- *ALWAYS* keep the tubing from the M702SS calibrator to the analyzer as short as possible. *USE* stainless steel tubing throughout, especially from the ammonia calibration bottle to the calibrator.
- If possible *HEAT* the sample line and *DRY* the sample gas.
- Sample filters *Will* cause response delays on both the rise and fall of the sample signal.

These rules apply also to your calibrator's internal plumbing. It is highly recommended that you use a M702SS calibrator in conjunction with the M201E. The calibrator has stainless steel plumbing throughout. The M700 calibrator contains Teflon tubing and internal MFC's that can be affected by the ammonia gas, therefore, the M700 calibrator is not recommend for use with the M201E analyzer. It is important to keep the sampling system well maintained.

1.3 SAMPLE FILTRATION

The instrument can be provided with an optional stainless steel sample filter P/N 05571. For minimum response time operation, the instrument should be supplied with clean sample gas at ambient pressure.

An additional filter resides in the M201E pneumatic pathway. The filter is a 1/4" diameter stainless steel sintered filter used to protect the reaction cell flow control orifice from plugging. This filter will plug rapidly if contaminated sample gas is not filtered before entering the analyzer.

NOTE: In situations where the sample gas is known to be contaminated with particulate material it is advisably to add extra filtration. However, it must be noted that the response time is directly extended through filter additions.

1.4 M201E ANALYZER SPECIFICATIONS

Table 1-1. M201E Operating Specifications

Ranges	0-50 to 0-2000 ppb in 1 ppb increments
Measurement Units	PPB, PPM, microgram/m ³ , milligram/m ³ (user selectable)
Noise at Zero¹	≤ 0.5 ppb RMS
Noise at Span¹	≤ 1.0% of reading above 50 ppb
Lower Detectable Limit²	1 ppb RMS
Zero Drift³	2 ppb / 24 hours
Span Drift	≤ 1.0% FS Range / 7 days
Lag Time	40 seconds
Rise Time⁴	90% 5 Min
Fall Time	90% 5 Min
Sample Flow Rate	1000 cm ³ /min ± 10% (500 cm ³ /min bypass to vacuum manifold, 500 cm ³ /min to reaction cell)
Linearity	2% of full scale
Temp Range	15-40°C
Dimensions HxWxD	7" x 17" x 23.6" (18cm x 43cm x 61cm)
Weight, Analyzer	43 lbs (20 kg)
Weight, Converter	24 lbs (11 kg)
Weight, Pump	16 lbs (7 kg)
Power, Analyzer	100V ~50/60 Hz, 120V ~60 Hz, 220V ~50Hz, 240V ~50 Hz, 125 watts
Power, Analyzer⁵	230V ~50 Hz, 125 watts
Power, Pump	110V ~60 Hz, 220V ~50 Hz, 240V ~50 Hz, 295 watts
Power, Pump CEMark⁵	230 V ~50 Hz, 2.5 A peak
Environmental	Installation Category Pollution Degree 2, Over-voltage Category II
Analog Output	4 user configurable outputs, each can be configured as 0.1, 1V, 5V or 10V. Three outputs convertible to 4-20mA isolated current loop.
Analog Output Resolution	1 part in 4096 of selected full-scale voltage (12 bit)
Serial I/O	1x RS-232, 1 x RS-485 or RS-232 or Ethernet(optional). Communication speed: 300 – 115200 baud (user selectable)
Status Option	8 status outputs from opto-isolators, 7 defined, 1 spare

1. As defined by USEPA

2. Defined as twice the zero noise level

3. At constant temperature and voltage

4. When pneumatics are conditioned with NH₃ overnight and the gases (zero air to NH₃) are manually switched at the sample inlet at the rear of the M501.

5. Electrical rating for CE Mark Compliance

2.0 CALIBRATION PROCEDURE

This section begins with a high-level overview of the calibration procedure for the M201E analyzer. Details are provided starting in Section 2.1:

- First, take the time to read the M200E manual to familiarize yourself with the Chemiluminescence process. It is important to remember that the analyzer is merely measuring different levels of nitric oxide sample gas on three separate channels (TN_x, NO_x, NO). The ammonia and nitrogen dioxide concentrations are then calculated using this information.
- Assemble the M201E analyzer according to the pneumatic configurations outlined in Figure 1-1. Remember: **DO NOT** pressurize the sample, span or zero ports (Zero/SPAN valves are optional) during calibration. Allow the analyzer to pull the gas through the system using the vacuum pump.
- Next, zero the analyzer using an approved zero air source, such as, bottled zero air, nitrogen or zero air generated by a Teledyne-API M701 zero air source. This sets the zero offset for the three individual channels (TN_x_OFFS, NO_x_OFFS, NO_OFFS). Confirm that all displayed concentrations read zero.
- Span the analyzer using bottled nitric oxide gas diluted to a level set to 80% of the expected sample range, preferably using a M702 Calibrator. This sets the slope for the three individual channels (TN_x_SLOPE, NO_x_SLOPE, NO_SLOPE). Confirm that displayed concentrations TN_x , NO_x and NO display the correct span concentration.
- If you haven't done so recently, conduct a GPT (gas phase titration) and confirm the molybdenum is functioning accordingly. Section 8.3.3 of the M200E manual outlines the GPT procedure. Section 7.0 of this manual consists of a service note for checking the molybdenum converter. There should be no reason to adjust the molybdenum efficiency factor on a new analyzer. If a diluted bottled of nitrogen dioxide gas is used to determine the molybdenum efficiency, allow enough time for the span value to stabilize. Nitrogen dioxide exhibits similar hold up issues as ammonia gas. Therefore, it may take a number of hours before the NO_x reading stabilizes.
- Span the analyzer using bottled ammonia gas diluted to a level set to 80% of the expected sample range, preferably using a M702 Calibrator. **Note:** The first time bottled ammonia is connected to the gas dilution system, regulator/calibrator, the TN_x reading may take a number of hours to stabilize.

2.1 ZEROING THE ANALYZER

The analyzer can be zeroed by either applying zero air straight to the sample port or through the optional Zero/Span valves, if installed. It is important to remember that if the analyzer was previously sampling ammonia gas, prior to conducting a Zero calibration, it will take some period of time before the zero baseline is reached. The process of zeroing the analyzer consists of delivering dry zero air to the analyzer. The operator then manually zeros the TN_x and NO_x channels individually through the user interface. The following Tables outline the steps necessary to zero the analyzer.

Table 2-1. Zero Calibration Procedure – Zero Gas Through the SAMPLE Port

Important: Each channel (TN_x and NO_x) must be zeroed individually

Step No.	Action	Comment
1.	Press CAL	The M201E enters the calibrate mode from sample mode. Confirm zero gas is flowing past the sample port.
2.	Channel Selection	Press TN_x or NO_x then Press ENTR .
3.	Range Selection	Press LOW or HIGH range then Press ENTR . Always calibrate the LOW range, section 3.0 below.
4.	NH ₃ STB Reading	Wait for the displayed stability reading to fall below 1.0 PPB. The lower the stability reading the better the zero value.
5.	Press ZERO	If you change your mind after pressing ZERO , you can still press EXIT without zeroing the instrument. You don't have to enter concentration values. The analyzer knows to apply 0 PPB.
6.	Press ENTR	Pressing ENTR actually adjusts the Offset value for the selected channel.
7.	Press EXIT	The M201E returns to sampling mode.
8.	Check Concentrations /Offsets	All displayed concentrations should read zero. The offset values should be close to zero (-20 to 150 mv)

Table 2-2. Zero Calibration Procedure - Zero Gas Through ZERO Port

Step No.	Action	Comment
1.	Press CALZ	The M201E enters the calibrate mode from sample mode. The zero gas is supplied through the ZERO inlet port on the rear panel of the M501NH.
2	Table 2.1	Follow Steps 2 to 8 in Table 2-1.

Notes:

- Since the zero gas concentration is defined as 0 ppb, it is not necessary to enter the expected concentration values.
- Both the TN_x and NO_x channels must be zeroed individually. When you zero the NO_x channel both the offsets for NO_x and NO are configured. All readings should display zero following this action.
- It is recommended that the calibration of both the TN_x and NO_x channels be done at one time.
- Always confirm that excess zero air is flowing past the sample or zero port, if the Zero/Span option is present, on the rear of the M501NH converter. There should always be some excess flow. If insufficient flow is supplied to the analyzer ambient gas will be entrained and the zero offset values will be incorrect. However, it is important not to over pressurize the analyzer.
- It is a good idea to allow the analyzer to sample zero gas for extended periods following zero calibration. Large drifts can signify leaks or indicate an issue with the zero air source.

2.2 SPANNING THE ANALYZER WITH NITRIC OXIDE GAS

The analyzer can be spanned by either applying nitric oxide gas straight to the Sample port or through the Zero/Span valve option, if installed. It is important to remember that if the analyzer was previously sampling ammonia gas, prior to conducting a nitric oxide span calibration, it will take some period of time before the TN_x channel stabilizes. The process of spanning the analyzer consists of diluting bottled gas, using a calibrator and delivering to the analyzer. The operator then manually spans the TN_x and NO_x channels individually through the

user interface. The following Tables outline the manual steps necessary to span the analyzer.

Table 2-3. NO Calibration Procedure – NO Gas Through the SAMPLE Port

Important: Each channel (TN_x and NO_x) must be Spanned individually

Step No.	Action	Comment
1.	Press CAL	The M201E enters the calibrate mode from sample mode. Confirm that excess NO gas is flowing past the sample port.
2.	Channel Selection	Press TN_x or NO_x then Press ENTR .
3.	Range Selection	Press LOW or HIGH range then Press ENTR . Always calibrate the LOW range, Section 3.0below.
4.	Press CONC	<p>If NO_x was chosen previously then the following will be displayed: NO_x NO CONV Exit Press NO_x, If you are delivering 450 PPB of NO then Enter 450 PPB, Press ENTR. Repeat the same steps for NO. Press EXIT Once stability has been achieved, Press SPAN, ENTR, EXIT NOTE: Both NO_x and NO should read 450 PPB.</p> <hr/> <p>If TN_x was chosen previously then the following will be displayed: TN_x CONV Exit Press TN_x enter 450 PPB, Press ENTR Press EXIT Once stability has been achieved, Press SPAN, ENTR, EXIT TN_x should read 450 PPB.</p>
5.	Check Slopes	The slopes should be close to 1.0 +/- 0.300

Table 2-4. NO Calibration Procedure - NO Gas through the SPAN Port

Step No.	Action	Comment
1.	Press CALS	The M201E enters the calibrate mode from sample mode. The NO gas is supplied through the SPAN inlet port on the rear panel of the M501NH.
2	Table 2.3	Follow Steps 2 to 5 in Table 2-3.

Notes:

- Both the TN_x and NO_x channels must be spanned individually with nitric oxide gas. When you span the NO_x channel both the NO and NO_x concentrations must be manually inputted.
- It is recommended that the calibration of both the TN_x and NO_x channels be done at the same time.
- Always confirm that SPAN gas is flowing past the sample or span port on the rear of the M501NH converter. There should always be some excess flow. If insufficient flow is supplied to the analyzer ambient gas will be entrained and the span values will be incorrect. However, it is important not to over pressurize the analyzer.
- It is a good idea to allow the analyzer to sample span gas for extended periods following span calibration. Large drifts can signify leaks or indicate an issue with the span gas source.
- If after spanning with nitric oxide, the analyzer slopes are out of range conduct the following:
 - Confirm the gas sources are good. Usually the bottle is certified to a known level of nitric oxide. The bottle should be balanced with nitrogen. Try not to use the same regulator for nitric oxide as was used on ammonia. This also holds for the tubing between the different bottles and the mixing source (calibrator).
 - Confirm the zero reading is good by delivering Zero gas.
 - Confirm that the concentration delivered to the analyzer is equal to what you entered under the **CONC** menu **NO_x** and **TN_x**.
 - Leak check both the M501NH and analyzer together.
 - Using section 11.6.5 of the M200E manual confirm that the PMT sensor hardware calibration is set correctly.

2.3 SPANNING THE ANALYZER WITH AMMONIA GAS

The most important criterion an individual can avail themselves of when spanning an analyzer with ammonia gas is “patience”. Ammonia is a very sticky gas and the response of the analyzer/calibration system depends on a number of factors. The following lists some important points the user should be aware of when calibrating:

- Is this the first time the analyzer/calibration system has seen ammonia gas in the last couple of days? If so, spanning to a fixed value will take considerably longer than normal: possibly 12 hours to completely stabilize.
- Is the tubing that is delivering span gas from the calibration bottles, made of stainless steel? Is the tubing from the rear of the calibrator to the analyzer, made of stainless steel? Where possible use stainless steel tubing.
- **Note:** The operator is responsible for delivering a set amount of ammonia to the analyzer, calculating the converter efficiency of the M501NH and entering the efficiency value through the user interface, if required.
- Is the environment where the analyzer resides undergoing large temperature swings (+/- 5 C about the norm Temperature)? If so the sample line can absorb and desorb ammonia at concentration rates that are distinguishable to the analyzer. If possible, heat the sample line to a constant maximum ambient temperature. Otherwise the *FILT_SIZE = 42 Samples* variable located under the VARS MENU can be lengthened. However, lengthening the filter size slows the rise/fall response time of the analyzer.
- Does the sampling environment contain large amounts of particulates? If so, it may be necessary to add the sampling filter option. As outlined previously, this will affect the analyzer response.
- One method to increase the response of both the sampling system and the analyzer is to flow a larger concentration of ammonia gas through the pneumatics for a couple of hours. For example, if the expected range is 500 PPB of ammonia, then flowing 1.0 PPM speeds up the absorption which occurs throughout the pneumatics. The long delays in ammonia response occur when the analyzer hasn't sampled the gas for some time. Ammonia desorbs from the pneumatics, these surfaces need to be rewetted before span stability is achieved.
- Prior to conducting the ammonia calibration, confirm that the ammonia converter efficiency is initially set to 1.000 using the following menu key selections:

Table 2-5. Confirming Ammonia Converter Efficiency

Step No.	Action	Comment
1.	Press CAL	The M201E enters the calibrate mode from Sample mode.
2.	Channel Selection	Press TN_x then Press ENTR .
3.	Range Selection	Press LOW range then Press ENTR .
4.	Press CONC	The following will be displayed: TNx CONV Exit Press CONV enter 1.0000 , Press ENTR Press EXIT, EXIT

Table 2-6. NH₃ Calibration Procedure – NH₃ Gas Through The SAMPLE Port

Step No.	Action	Comment
1.	Generate a known level of NH ₃ gas using a calibration gas source	Monitor the TN _x concentration until it has stabilized; this signifies that both the NO _x and NH ₃ gases have stabilized. This could range from 20 minutes to several hours depending on whether the analyzer / calibration system has recently been subjected to ammonia gas.
2.	NH ₃ Conversion efficiency calculation	When the TN _x channel is stable, note the concentration of NH ₃ displayed. The calculation for the NH ₃ Conversion efficiency is: (Displayed NH ₃ concentration) divided by (Delivered NH ₃ concentration) Example: The operator is delivering 450 PPB of NH ₃ . The displayed concentration for NH ₃ is 440 PPB then the efficiency factor = 440/450 = 0.9777
3.	Press CAL	The M201E enters the calibrate mode from Sample mode.
4.	Channel Selection	Press TN_x then Press ENTR .
5.	Range Selection	Press LOW range then Press ENTR .
6.	Press CONC	Since TN _x was chosen previously, then the following will be displayed: TN_x CONV Exit Press CONV enter 0.9777 , Press ENTR Press EXIT, EXIT

- **Note:** In the example outlined above, the displayed ammonia concentration is being increased by 2.27%. Newer M501NH converters should have efficiency values very close to 1.00. Depending on the operator's acceptable level of error, it may not be necessary to change the efficiency factor from 1.00. Therefore, calibration with nitric oxide gas is all that is required.
- The efficiency factor may also be changed by entering the VARS MENU and editing **NH3_CE_FACTOR1 = 1.0000**.

Table 2-7. NH₃ Calibration Procedure – NH₃ Gas through the SPAN Port

Step No.	Action	Comment
1.	Press CALS	The M201E enters the calibrate mode from Sample mode. The ammonia gas is supplied through the SPAN inlet port on the rear panel of the M501NH. Calculate the Efficiency factor as outlined in Steps 2 in table 2.5.
2	Table 2.5	Follow Steps 4 to 6 in table 2.5.

Note: When using the Zero/Span valve option to span with ammonia, the analyzer response is greater than spanning through the sample Port.

This page intentionally left blank.

3.0 CONFIGURABLE ANALOG OUTPUT OVERVIEW

There are three different methods to extract concentration data from the E-Series analyzers. By one method, the operator can set up an iDas (internal data acquisition) configuration either through the user display or using TAPI's windows based software called APICOM. The analyzer stores data internally, which is available later for download through the RS-232 or Ethernet port. The second method involves the use of hyperlink where the user sends text based commands, to retrieve data, through the RS-232 port. With the third method, the operator can interface a strip chart recorder and/or data-logger to the analyzer analog outputs. The following sections outline the steps necessary to calibrate and configure the analog outputs.

There are four analog outputs on the rear of the analyzer. The default configurations of the M201E analog outputs are as follows:

Table 3-1. Analog Output Data Default Settings

ANALYZER	CHANNEL DEFAULT SETTING			
	A1	A2	A3	A4
M201E	TNxCNC1	NH ₃ CNC1	NOCNC1	NO ₂ CNC1
	5 Volts	5 Volts	5 Volts	5 Volts
	500 PPB	500 PPB	500 PPB	500 PPB

To access these signals attach a strip chart recorder and/or data-logger to the appropriate contacts of the analog output connector on the rear panel of the analyzer.

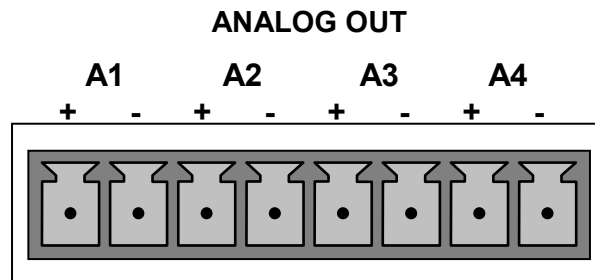

Figure 3-1. Analog Output Connector

Table 3-2. Analog Output Pin-Outs

PIN	ANALOG OUTPUT	VOLTAGE SIGNAL	CURRENT SIGNAL
1	A1	V Out	I Out +
2		Ground	I Out -
3	A2	V Out	I Out +
4		Ground	I Out -
5	A3	V Out	I Out +
6		Ground	I Out -
7	A4	V Out	N/A
8		Ground	N/A

Additionally A1, A2 and A3 may be equipped with optional 0-20 mA current loop drivers. The 4-20 mA option is not available on A4.

Note: In actuality the analog output configuration of the analyzer may be different than stated above. The outputs can be configured differently at the factory depending on whether they were assigned during the procurement of the product. It is possible to check the configuration of the analyzer by accessing the ANALOG I/O CONFIGURATION through the DIAG menu.

The analyzer operates in Dual Mode during gas detection. This means each of the measured concentrations can have two separate slopes and offsets, one for the low range and one for the high range. Though uncommon, a user may decide to calibrate the analyzer with nitric oxide at, for example, 100 PPB using the LOW range and then perform another calibration at 450 PPB using the HIGH range. Through the analog outputs the user can then assign analog output A1 to TN_xCNC1 and output A2 to TN_xCNC2. Gases with the “1” designation use the slope and offset for the LOW range, while gases with the “2” designation will use the slope and offset for the HIGH range. It is recommended that both the LOW and HIGH ranges be calibrated at the same time. Independent of whether the HIGH range is actually being outputted to the analog outputs.

3.1 ANALOG OUTPUT - ELECTRONIC CONFIGURATION

The final step in configuring the analyzer's four analog output channels is to set the electronic signal type and range of each channel. This consists of:

- Selecting an output type for A1 – A4 (voltage or current if an optional current output driver has been installed) and the signal level that matches the input requirements of the recording device attached to the channel.
- Calibrating the electronic circuitry of the output channel. For each channel this can be done either automatically or manually.
- Adding a bipolar recorder offset to the signal if required.

In its standard configuration the analyzer's Analog Outputs can be set for the following DC voltage signal levels. Each range is usable from -5% to + 5% of the rated range.

Table 3-3. Analog Output Voltage Range Min/Max

RANGE SPAN	MINIMUM OUTPUT	MAXIMUM OUTPUT
0-0.1 VDC	-0.005 VDC	0.105 VDC
0-1 VDC	-0.05 VDC	1.05 VDC
0-5 VDC	-0.25 VDC	5.25 VDC
0-10 VDC	-0.5 VDC	10.5 VDC
The default offset for all ranges is 0 VDC.		

The following DC Current output options are also available from the factory:

Table 3-4. Analog Output Current Loop Min/Max

RANGE SPAN	MINIMUM OUTPUT	MAXIMUM OUTPUT
2-20 mADC	1 mADC	21 mADC
4-20 mADC	3 mADC	21 mADC
The default offset for all ranges is 0 mADC.		

3.2 ANALOG OUTPUT SIGNAL TYPE AND RANGE SELECTION

To select an analog output signal type (DC voltage or current) for one of the analyzer analog output channels press SETUP - MORE -DIAG - 818...ENTER-NEXT...NEXT:

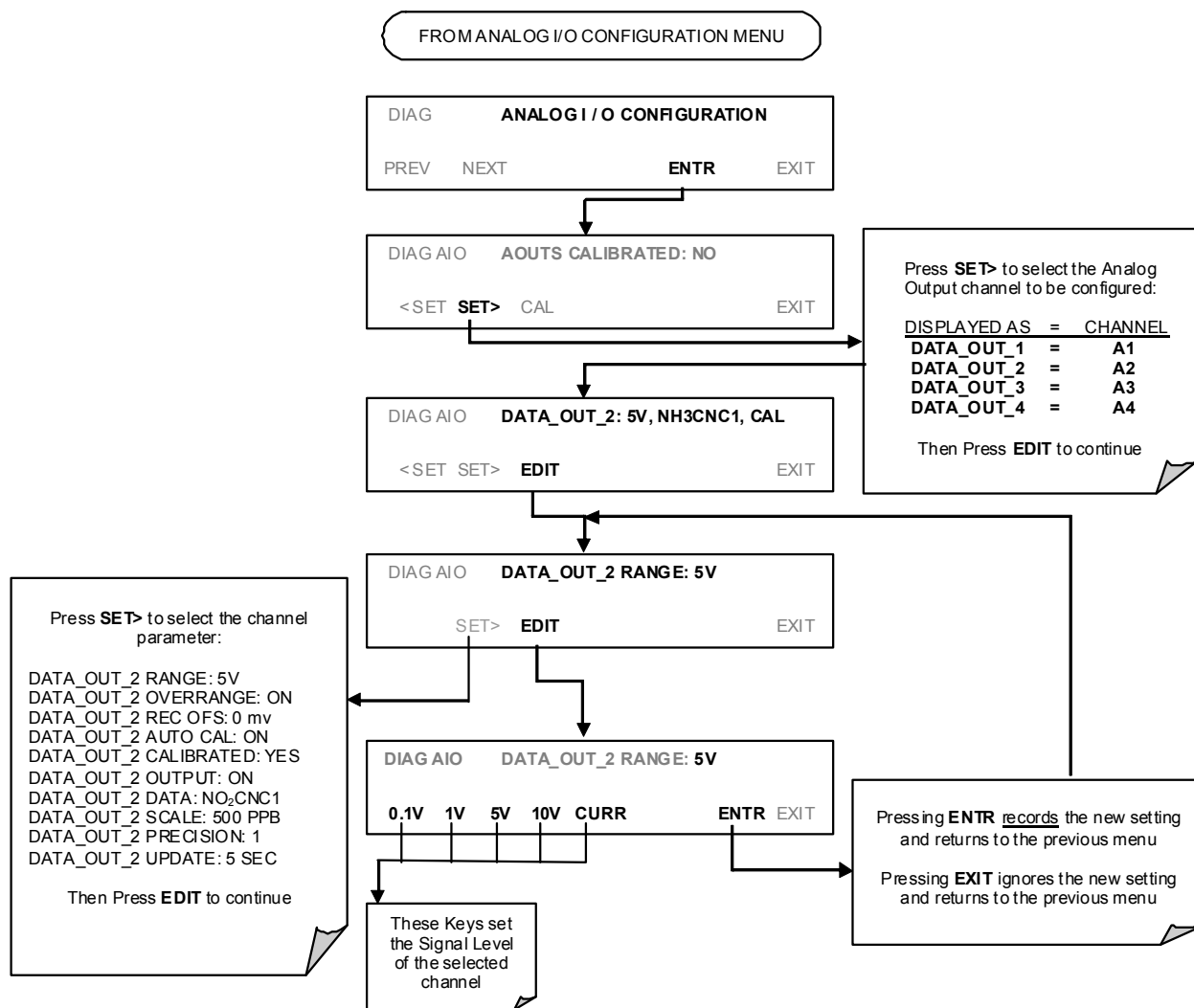

Figure 3-2. Analog Output Signal Type

3.3 SELECTING AUTO OR MANUAL ANALOG OUTPUT CALIBRATION

The analog outputs configured for voltage mode can be calibrated either automatically or manually. In its default mode the instrument is configured for automatic calibration. **Note:** manual calibration should only be used for the 0.1V range or in cases where the outputs must be closely matched to the characteristics of the recording device. Outputs configured for automatic calibration can be calibrated as a group or individually.

To select auto-calibration for a particular channel press the following:

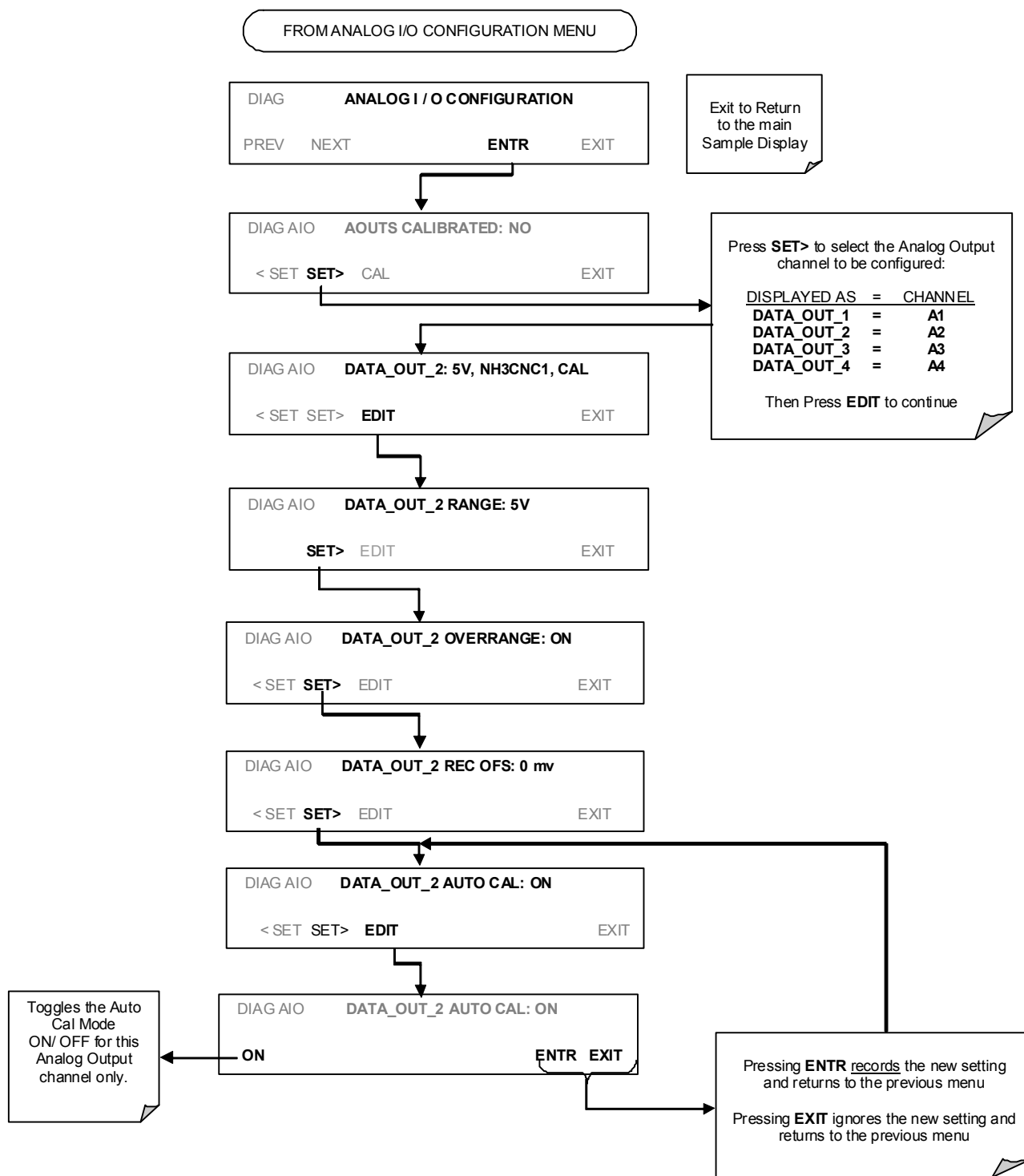

Figure 3-3. Auto Or Manual Analog Output Calibration

To calibrate the output channels as a group press the following, (**Note:** this is the recommended calibration approach):

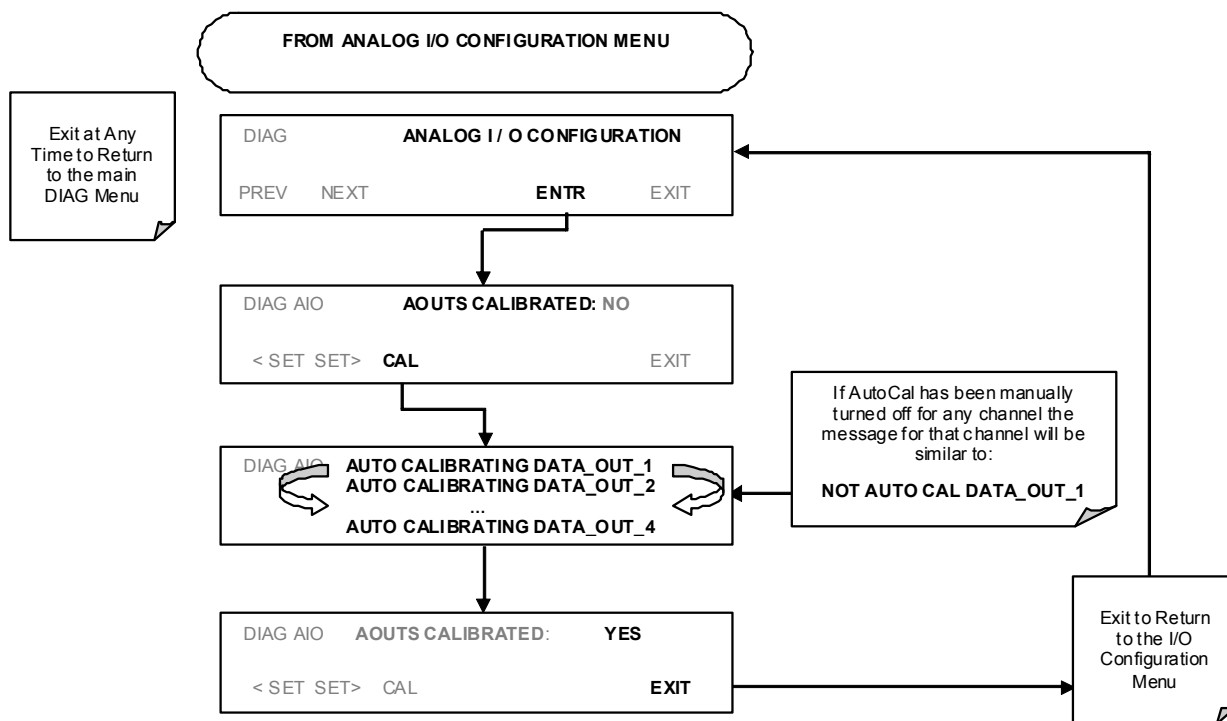

Figure 3-4. Analog Output Group Calibration

3.4 MANUALLY CALIBRATING ANALOG OUTPUT SIGNAL LEVELS

The analog outputs in voltage mode can be manually calibrated to closely match the characteristics of the data recorder. Outputs configured for 0.1V full scale should always be calibrated manually.

Calibration is done through the instrument software in conjunction with a voltmeter connected across the output terminals. Adjustments are made using the front panel keys. First the zero-point is set then the span-point.

The software allows this adjustment to be made in 100, 10 or 1 count increments.

Table 3-5. ZERO/SPAN Analog Output Signal Calibration Tolerances

Full Scale	Adjust Zero Within	Span Voltage	Adjust Span Within
0.1 VDC	±0.0005V	90 mV	±0.001V
1 VDC	±0.001V	900 mV	±0.001V
5 VDC	±0.002V	4500 mV	±0.003V
10 VDC	±0.004V	4500 mV	±0.006V

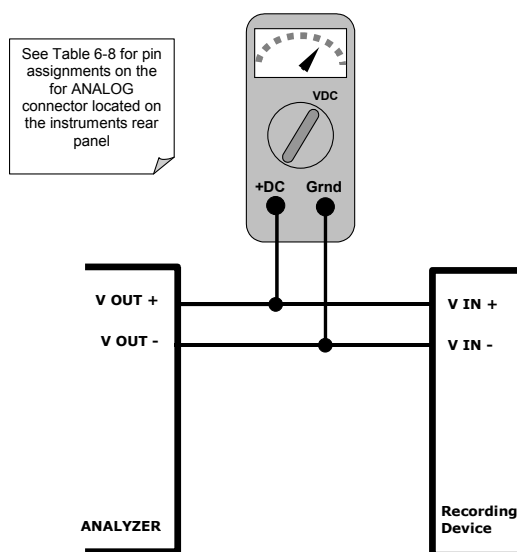

Figure 3-5. Setup For Calibrating Analog Output Signal Levels

To make these adjustments the auto calibration feature “DATA_OUT_1 AUTO CAL: OFF” must be turned off for each output channel then press the following:

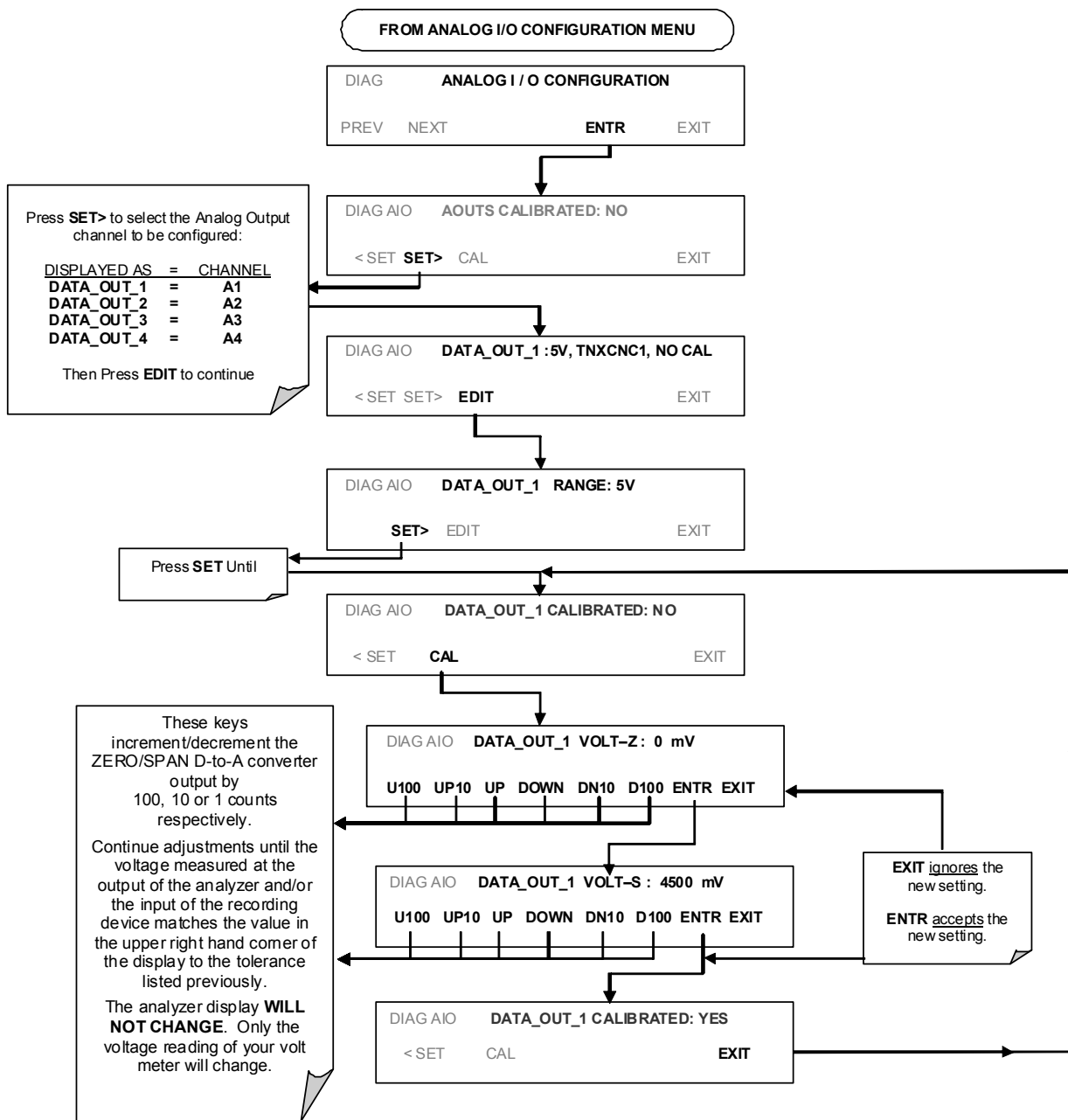

Figure 3-6. Analog Output Manual Calibration

3.5 ANALOG OUTPUT RECORDER OFFSET ADJUSTMENT

An offset can be added to individual output channels by pressing the following:

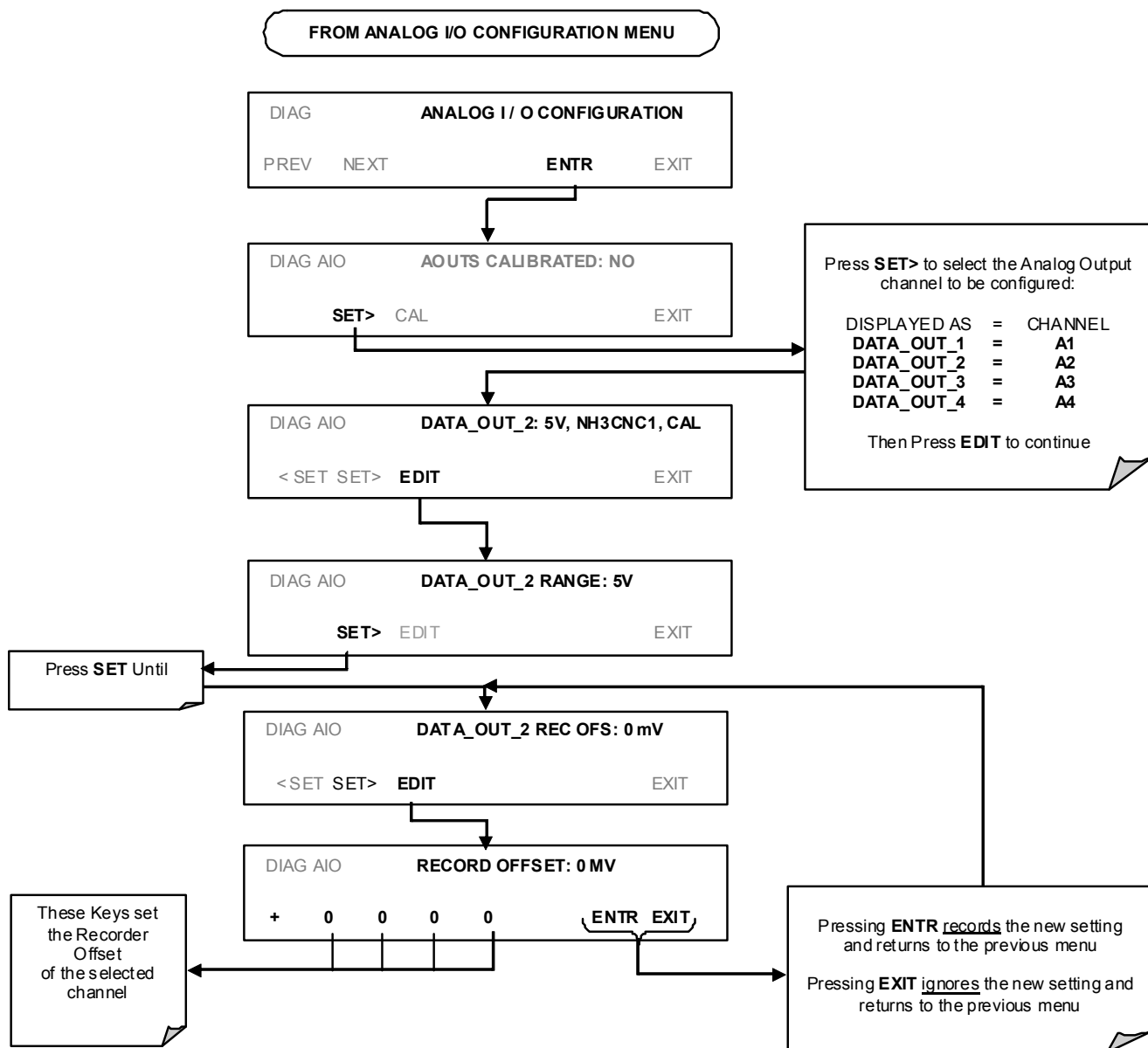

Figure 3-7. Analog Output Recorder Offset Calibration

4.0 MAINTENANCE SCHEDULE

The maintenance requirements of the M201E are the same as a standard M200E NO_x analyzer but with additional maintenance items (Table 4-1). Please refer to Section 13 in the M200E Operator Manual for the M200E maintenance schedule and for maintenance and repair procedures.

The M201E requires the following additional maintenance items.

Table 4-1. Preventative Maintenance Schedule

Item	Maintenance Interval	Reference Section
NO ₂ molybdenum converter	Test Every Three Months	Section 8.2.3 M200E Manual
M501NH ₃ Converter		Section 4.1 of this manual.
Reaction Cell	Clean annually or as necessary	Section 9.3.9 M200E Manual
AutoZero flow check	Quarterly as needed	Section 4.4 of this manual.

4.1 M501NH MAINTENANCE

The M501NH external converter is operated at 825 °Celsius. Because of this the stainless steel ¼" tube internal to the converter slowly oxidizes and may require replacement. Over time the converter's efficiency will degrade, due to aging of the internal catalyst. This is characterized by a CONV value on the TNx channel of < 0.8 or > 1.2, despite the converter being at temperature. The efficiency of the converter should be checked quarterly. The converter should be cleaned out on a yearly basis by removing the outer tube and shaking the fine dust particles from both the outer and inner tubes. This is also a good time to replace the catalyst screen, if necessary.

The following procedure describes how to disassemble and replace converter parts. The various parts in the converter become delicate and brittle after prolonged exposure to high temperatures. It is therefore a good idea to have a complete set of replacement parts on hand before starting, as listed in Table 4-2.

Table 4-2. M501NH Converter Rebuild Parts List

Part No.	Description
KIT000193	RETROFIT, M501NH INNER TUBE w/SCREEN
KIT000139	REBUILD, CERAMIC BUSHINGS, M501NH
HE0000007	CERAMIC HEATER, 220W@60V M501XX

4.2 REPLACING THE CATALYTIC CARTRIDGE

1. Turn off power to the converter and allow to cool. **IT IS VERY IMPORTANT THAT THE CONVERTER BE COOL BEFORE ATTEMPTING ANY DISASSEMBLY OR REPAIRS.**



CAUTION VERY HOT

Will cause severe burns – disassembly while hot will damage other converter components. Allow sufficient time to cool.

2. Remove the chassis cover of the M501NH, remove the aluminum cover over the oven, remove the two U-shaped hold down clamps.
3. Disconnect the 1) stainless steel and 2) PTFE tubes from the converter cartridge.
4. Loosen the nut holding the cartridge assembly in the U-shaped angle bracket mounted on the chassis floor.
5. Gently lift and tilt the converter assembly out of the U-shaped bracket and slide the assembly out of the oven.
6. Loosen the 1/4" SS tube fitting nearest the hold-down bracket; this fitting holds the central tube in the converter. Replace the tube that is part of KIT000193.
7. Re-assemble the converter by doing the above steps in reverse order.

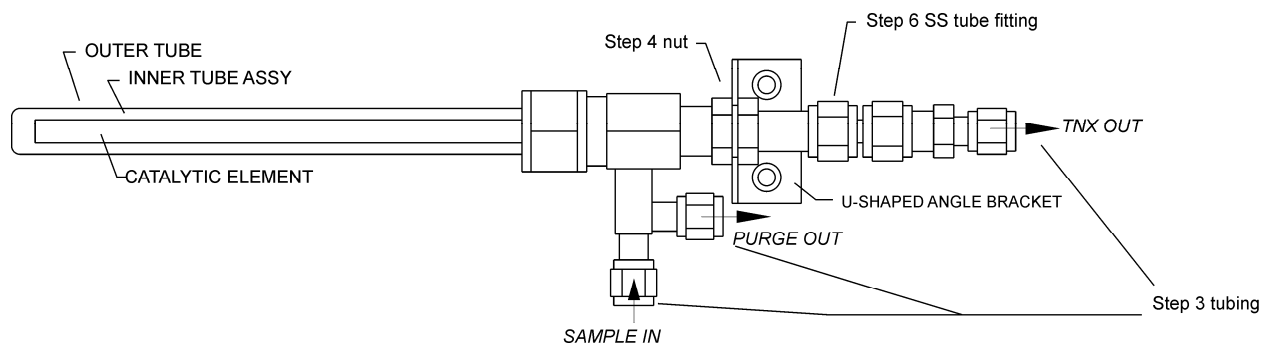

Figure 4-1. Catalytic Cartridge

4.3 REPLACING THE THERMOCOUPLE

The following instructions provide the necessary information to replace the existing thermocouple. Figure 4-2 is provided for reference.

You must obtain the following replacement parts kit from T-API:

- 010820000 , Type K thermocouple

You will need the following tools:

- Nutdriver, $\frac{5}{16}$
- Nutdriver, $\frac{11}{32}$
- Diagonal Cutter
- Philips head Screwdriver #2

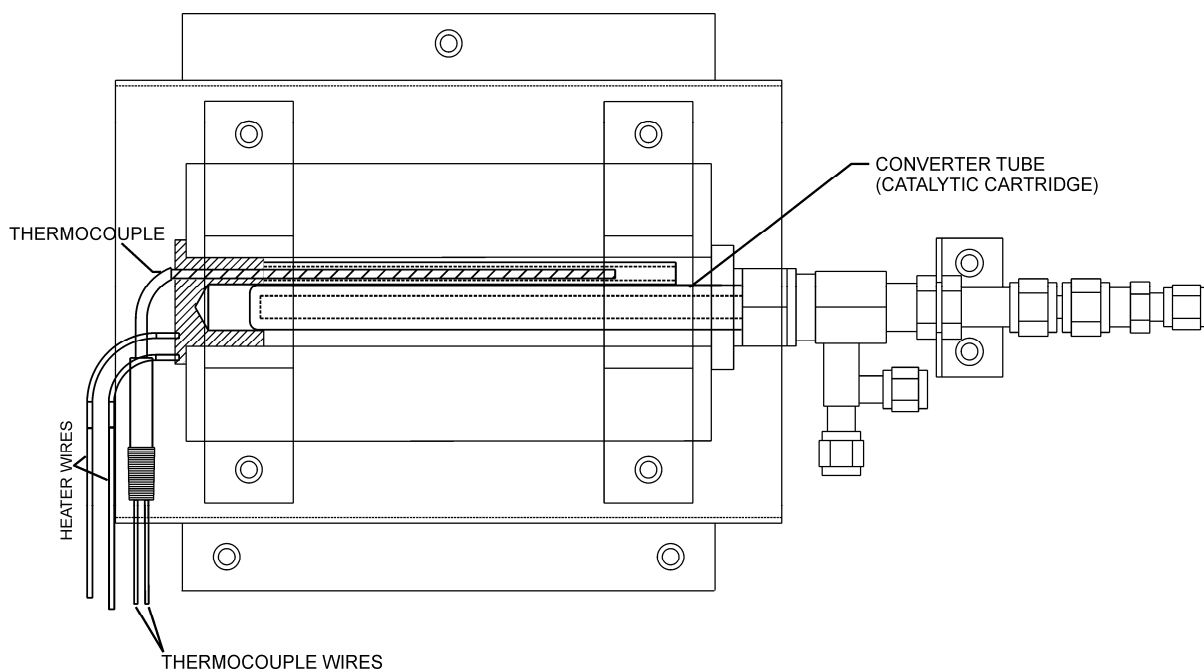
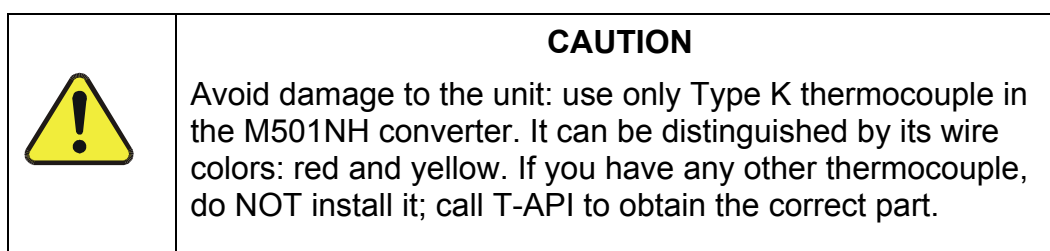

Figure 4-2. Thermocouple Location

Once you have the right tools and parts, replace the thermocouple as follows:

1. Ensure power is removed from the M501NH Converter. If the Converter has been operational you will need to wait for at least 2 hours for the Converter oven to cool before continuing with the replacement of the thermocouple.

2. Remove the cover from the Converter chassis.
3. Unscrew the (4) nuts that secure the front panel to the chassis. They are located just behind the Front Panel along the top.
4. Lower the Front Panel to gain easier access to the end of the quartz tube.
5. Unscrew the (3) nuts that secure the inner cover protecting the Heater Block and quartz tube. Remove this cover.
6. Cut the tie-wrap that secures the thermocouple to the fitting at the end of the quartz tube.
7. Loosen the Teflon fitting at the end of the quartz tube taking care not to put any stress on the tube, and slide the fitting off the tube.
8. Remove the thermocouple.
9. Disconnect the thermocouple wires from the Temperature Controller noting that the 'Yellow' wire goes to pin 1 and the 'Red' wire goes to pin 2.
10. The thermocouple should slide into the Heater Block.
11. Replace the Tie-Wrap Hold-Down.
12. Form the thermocouple wire so that it rests in the cavity with little movement.
13. Connect the (2) wires of the thermocouple to the Temperature Controller. The "yellow" wire should be connected to pin 1 and the "red" wire should be connected to pin 2.
14. At this point, all connections have been made, both electrically and pneumatically. A leak check should be performed on the Converter to verify that all connections are leak free. If a leak is detected, the leak should be resolved before continuing.
15. Install the inner cover of the Heater Block and secure with the (3) nuts. Close the Front Panel and secure with the (4) nuts. Install the top cover on the Converter chassis.
16. The Converter is now ready for the application of power. You will be looking for an indication from the Temperature Controller that it is functioning correctly and driving the heater to the desired "set" temperature. Apply power now.
17. After the Converter comes to the regulated temperature, perform the Auto Tune function to tune the Temperature Controller to the new thermocouple.
18. After the Auto-Tune process is completed, verify that the "process" temperature is indicating that the desired temperature is stable and being regulated.

The converter is now ready for operation.

4.4 AUTOZERO FLOW CHECK

Since the M201E is an ammonia analyzer, the flow through the AutoZero orifice is especially important. Check the AutoZero flow as follows:

1. This procedure should be performed with the sample pump running.
2. Remove the top cover of the analyzer. Locate the vacuum manifold at the center rear of the chassis. Locate the 1/8" tube fitting located on the very left side, as viewed from the rear of the analyzer. It will have a label of "0.010" indicating the flow orifice installed.
3. Remove the fitting and attach a calibrated flowmeter to the block fitting capable of measuring in the range of 500 cc/min. The flowmeter should indicate a flow of 500 cc/min \pm 10%.
4. If the flow is outside this range (most likely lower, due to plugging):
 1. Turn off the sample pump and instrument.
 2. Remove the 1/8" pipe-to-tube fitting and remove the 1/4" sintered filter (p/n FL0000001). This filter is meant to protect the orifice; it will usually become plugged and need replacement rather than the orifice. Replace the filter, and then re-assemble the manifold. Restart the sample pump and recheck the flow.

Table 4-3. Analyzer Flow Check

<i>M501NH Converter sample flow check</i>		
Note: Connect both the Teflon™ tubes between analyzer and converter		
GAS PORT	Expected Flow (cc/min)	
"Sample In"	1000 +/- 10 %	
<i>Analyzer sample flow check</i>		
Note: Disconnect both the Teflon™ tubes between analyzer and converter		
GAS PORT	Expected Flow (cc/min)	
"To Conv"	1000 or 500, +/- 10 %	When the analyzer is sampling TNx only, the bypass flow is measured. Therefore, the flow alternates between 500 and 1000 cc/min. This is the NOx channel.
0		
"From Conv"	500 +/- 10%	This is the TNx channel.

This page intentionally left blank.

5.0 ALARMS AND CAUTIONS

A functional block diagram of the analyzer is shown in Figure 5-1.

5.1 ALARM

During initial warm up the internal Zero/Span factory option may exhibit a “Block Temperature” warning. This can be cleared once the block temperature stabilizes at 50 degrees Celsius. The block temperature is the actual temperature of the IZS block manifold inside the M501NH converter. If the block temperature warning exhibits a negative number such as (-37), then the umbilical cord is probably not attached or the Thermistor has become disconnected.

5.2 CAUTION

Be aware that the ammonia converter operates at 825 degrees Celsius. Do not flow highly flammable gases through the M201E analyzer. When the analyzer is not in use, it is advisable to turn off the M501NH. If the converter hasn't been powered for an extended period of time it is recommend that the analyzer be operated overnight prior to use.

Before spanning the analyzer it is good practice to observe the NORM PMT signal. Its value should be equal to twice the concentration of the delivered span gas. A common error made during calibration is to span the analyzer with either too low a gas concentration or an incorrect value entered into the CONC menu for TNx and NOx. Commonly this will cause a slope value much greater than one.

Note: Always zero then span as a basic rule of thumb.

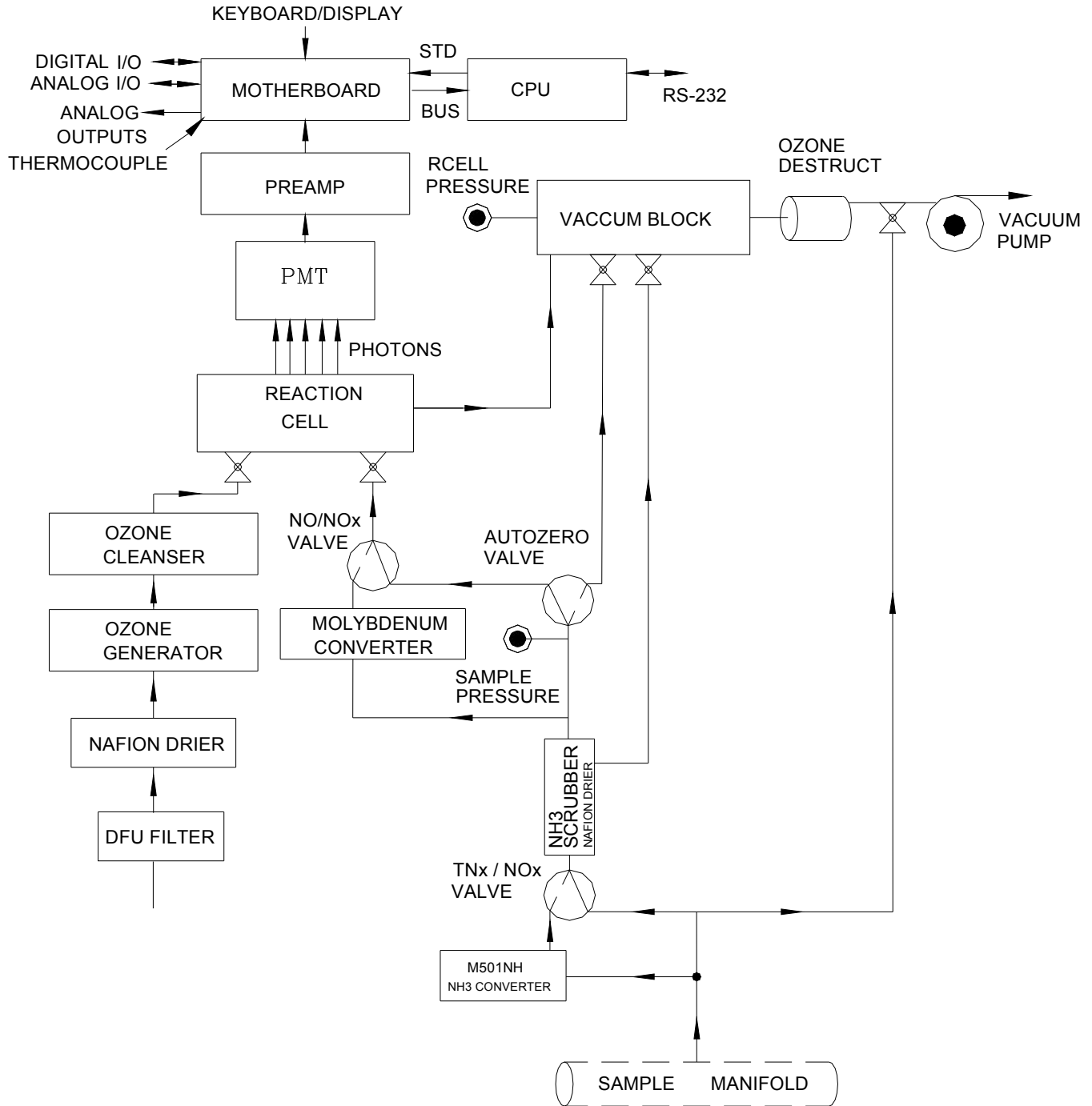

Figure 5-1. M201E Functional Block Diagram

6.0 M201E SPARE PARTS LIST

While this section lists the spare parts for the M201E, it is recommended that you refer to our Website or Sales for updates.

M201E Spare Parts List, Source: PN 06185H (DCN5494)	
Part Number	Description
000940100	CD, ORIFICE, .003 GREEN
000940400	CD, ORIFICE, .004 BLUE
000940500	CD, ORIFICE, .007 ORANGE
000940600	CD, ORIFICE, .010 BROWN
002730000	CD, FILTER, 665NM (KB)
005960000	AKIT, EXP, 6LBS ACT CHARCOAL (2 BT=1)
005970000	AKIT, EXP, 6LB PURAFIL (2BT=1)
009690200	AKIT, TFE FLTR (FL19) ELEM, 47MM, (100)
010820000	ASSY, THERMOCOUPLE, HICON, M501
011630000	HVPS INSULATOR GASKET (KB)
013140000	ASSY, COOLER FAN (NOX/SOX)
014080100	ASSY, HVPS, SOX/NOX
016680600	PCA, O3 GEN DRIVER, NOX, E SERIES
018080000	AKIT, DESSICANT BAGGIES, (12)
025070000	ASSY, IZS VALVE HEATER, M501NH
025250000	ASSY, VALVE/THERM, M501NH
037860000	ORING, TEFLON, RETAINING RING, 47MM (KB)
039700100	HEATER, BAND, TYPE K, DUAL VOLTAGE(KB)
040010000	ASSY, FAN REAR PANEL, E SERIES
040030800	PCA, PRESS SENSORS (2X), FLOW, E (NOX)
040400000	ASSY, HEATERS/THERMAL SWITCH, RX CELL
041710000	ASSY, CPU, CONFIGURATION, "E" SERIES * (USE WITH DOC 053150100)
041800500	PCA, PMT PREAMP, VR, M200E/EM/EH
041920000	ASSY, THERMISTOR, M200E (KB)
042580000	PCA, KEYBOARD, E-SERIES, W/V-DETECT
042680100	ASSY, VALVE (SS), M200E
043220000	TUBING, CERAMIC, .25OD X .156 ID
043220100	THERMOCOUPLE INSULATING SLEEVE, M501NH *
043940000	PCA, INTERFACE, ETHERNET, E-SERIES
044100000	MANUAL, OPERATORS, M200E
045230100	PCA, RELAY CARD, E SERIES
04550010A	ASSY, ORIFICE HOLDER, 4 MIL
04550030A	ASSY, ORIFICE HOLDER, 10 MIL, (NOX) (KB)

M201E Spare Parts List, Source: PN 06185H (DCN5494)	
Part Number	Description
046030000	AKIT, CH-43, 3 REFILLS
048620200	PCA, SERIAL INTERFACE, w/ MD, E SERIES (USE WITH ACROSSER CPU 041710000)
049310100	PCA, TEC DRIVER, PMT, M100/200, E SERIES
051211000	ASSY, O3 DESTRUCT W/FTGS (MNFLD - EXH) *
052060000	MANUAL, 201E STDL ADDENDUM
052930200	ASSY, BAND HEATER TYPE K, M200EX
053150100	DOC, w/SOFTWARE, M201E* (USE WITH ACROSSER CPU 041710000)
053950000	MANUAL, OPERATORS, M200E w/M201E ADDEND
055710000	ASSY, FLT, INLINE SS, 3/8" CONN, 0.5 MIC
058021100	PCA, E-SERIES MOTHERBD, GEN 5-ICOP (ACCEPTS ACROSSER OR ICOP CPU)
062390000	ASSY, MOLY GUTS w/WOOL, M101E/M200EX
062420200	PCA, SER INTRFACE, ICOP CPU, E- (OPTION) (USE WITH ICOP CPU 062870000)
062870000	CPU, PC-104, VSX-6150E, ICOP *(KB) (MUST USE WITH 058021100 MB)
063570100	DOM, w/SOFTWARE, M201E * (USE WITH ICOP CPU 062870000)
CH0000037	PURACARB AMMONIA
CP0000014	CONTROLLER, TEMP, W/PG-08 (CN262)
DS0000025	DISPLAY, E SERIES (KB)
FA0000006	FAN, 115VAC (KB)
FL0000001	FILTER, SS
FL0000003	FILTER, DFU (KB)
FL0000034	FILTER, DISPOSABLE, PENTEK (IC-101L)(KB)
FT0000010	CONNECTOR-ORING, SS, 1/8" (HK)
HE0000007	CERAMIC HEATER, 220W@60V M501XX
HW0000005	FOOT
HW0000020	SPRING
HW0000030	ISOLATOR, M100/M200 A/E/H/U
HW0000031	FERRULE, SHOCKMOUNT
HW0000036	TFE TAPE, 1/4" (48 FT/ROLL)
HW0000101	ISOLATOR
HW0000416	COVER, CRYDOM RELAYS, RL9, 19 and 20
HW0000453	SUPPORT, CIRCUIT BD, 3/16" ICOP
KIT0000095	AKIT, REPLACEMENT COOLER, A/E SERIES
KIT000219	KIT, 4-20MA CURRENT OUTPUT (E SERIES)
KIT000253	ASSY and TEST, SPARE PS37, E SERIES
KIT000254	ASSY and TEST, SPARE PS38, E SERIES
OR0000001	ORING, 2-006VT *
OR0000002	ORING, 2-023V
OR0000025	ORING, 2-133V
OR0000027	ORING, 2-042V
OR0000034	ORING, 2-011V FT10

M201E Spare Parts List, Source: PN 06185H (DCN5494)	
Part Number	Description
OR0000039	ORING, 2-012V
OR0000044	ORING, 2-125V
OR0000083	ORING, 105M, 1MM W X 5 MM ID, VITON
OR0000086	ORING, 2-006, CV-75 COMPOUND(KB)
OR0000094	ORING, 2-228V, 50 DURO VITON(KB)
RL0000015	RELAY, DPDT, (KB)
RL0000019	SSRT RELAY, TA2410, CE MARK
RL0000020	SSRT RELAY, TD2410, CE MARK
SW0000040	PWR SWITCH/CIR BRK, VDE CE (KB)
SW0000051	SWITCH, POWER CIRC BREAK VDE/CE, w/RG(KB)
SW0000058	SWITCH, THERMAL/450 DEG F
WR0000008	POWER CORD, 10A

This page intentionally left blank.

7.0 CALCULATING MOLY CONVERTER EFFICIENCIES

7.1 PURPOSE

To provide instructions on how to calculate the efficiency of a Moly converter when using a GPT method of testing converters, by using the US EPA method, where the actual concentration of ozone is not a factor in the accuracy of the calculation of the converter efficiency. This procedure is based on the Code of Federal Regulations, Title 40, Chapter I, subchapter C, Part 50, Appendix F.

7.2 TOOLS

API M700 calibrator with O3 Gen option (or equivalent)

7.3 PARTS

NONE

7.4 PROCEDURE

1. For the sake of numbers to input into this note, we have chosen 450 PPB NO gas as our reference point, you don't have to pick these values, they are just an example. There is also an assumption that the analyzer has a good calibration done @ 450 PPB NO span gas. If this is not the case, then once you are done with the leak check on the analyzer input your 450 PPB NO span gas and calibrate the analyzer.

NOTE: for the GPT to be performed correctly, there must be a minimum of 10% MORE NO than O3 produced. For example, if the Ozone produced is 400 PPB then the NO used must be 440 or more. Typically 450 PPB NO is made and 400 PPB of Ozone is produced.

2. Leak check machine to ensure that there are no leaks in the analyzer.
3. If you have input a CE factor into the instrument firmware (this would be in the CAL-CONC-CONV-SET menu) other than 100%, change this back to 100% for the duration of this test.
4. The first gas check is to test to see how much the converter is eating NO gas or out gassing NO gas. Bypass the converter in the machine, by placing a short piece of tubing in place of the converter. Perform a straight dilution with NO gas and air as a diluent gas. Input this 450 PPB NO gas into the analyzer, allow the machine to stabilize, and write down the NOx value on your data sheet on line 3.

5. Remove the converter bypass and install the converter back into the NO_x sample stream, such that the NO sample goes through the converter again and allow the machine to stabilize. Write down your NO_x value on your data sheet on line 4 AND line 6 of the data sheet.
6. Note the NO value and input that on line 9 of the data sheet.
7. Subtract line 3 from line 4 and write that number down on line 5. The spec on the data sheet is the value that we use here in house, and your spec might be a bit higher. We have found that on NEW Moly converters this spec is a good one that predicts a good performing Moly converter, but in an older converter might eat a bit more NO, and this would be acceptable. If it is a constant value, or changes little over time, this is not a problem the machine will calibrate this out.
8. The next step is to perform your GPT. Generate the same 450 PPB NO gas and input 400 PPB of O₃ (or generate 450 PPB NO and 400 PPB NO₂, if that's what your calibrator says). Allow the machine to stabilize for 10 minutes and then write down the NO_x value on line 7 and the NO value on line 10.
9. Subtract line 7 from line 6 and put that onto line 8
10. Subtract line 10 from line 9 and put that onto line 11
11. Put the number from line 8 into the letter A on line 12 and put the number from line 11 into the letter B on line 12.
12. Divide A by B and multiply it by 100 and put it into letter C on line 12.
13. Put the number in letter C onto the C on line 13 and subtract that value from 100 and put it into letter D on line 13. this is the converter efficiency.
14. This value should be >96%. For CEMS applications, a CE of <96% might be acceptable, depending on application and the guideline set up by the regulatory agency. In any application, check with your regulatory agency to see what the minimum CE factor is before replacing the converter.

MOLY TEST DATA SHEET

Line #	TEST	RESULT
--------	------	--------

2	LEAK-CHECK (WHEN HOT)	YES / NO
3	NO _x RESPONSE (MOLY BYPASSED)	_____
4	NO _x RESPONSE (MOLY IN-LINE)	_____
5	OUT-GASSING / EATING (NO – NO_x)	_____ (>-5 PPB, <5
	PPB)	
6	(NO _x ORIG) (NO _x mode, O ₃ off)	_____ PPB
7	(NO _x REM) (NO _x mode, O ₃ on)	_____ PPB
8	NO_x LOSS (9A - 10B)	_____ (A) (<4% of
	NO _x ORIG;	ex: for
	450PPB	
	4% is 18PPB)	
9	(NO ORIG) (NO mode, O ₃ off)	_____ PPB
10	(NO REM) (NO mode, O ₃ on)	_____ PPB
11	NO₂ (9B - 10A)	_____ (B)
	(>300PPB)	

12 Efficiency LOSS [(**A** / **B**) x 100] = [(_____ **A** _____ / _____ **B** _____) x 100] = _____ **C** _____ %

13 Total Conv Eff [100% – **C**] = 100% - _____ **C** _____ = _____ **D** _____ % (≥ 96%)