

**Teledyne API, Model 265A Chemiluminescence Ozone Analyzer Manual Addendum,
03389, Rev. B, DCN 5254**

HIGHLIGHTS

The purpose of this Highlights Page is to list the changes that were incorporated into this Manual per DCN 5254.

Chapter / Page Number	Description
Title Page	<ul style="list-style-type: none">• Changed Revision number and date.• Changed address.• Added DCN number to footer.• Removed Revision letter referenced to instruction manual.
Text – All Pages	<ul style="list-style-type: none">• Changed Revision number and date.• Added DCN to all footers of Text, P/N 03389B.• Added “PRINTED DOCUMENTS ARE UNCONTROLLED” to all footers of Manual, P/N 03389B.
TOC / ii, iii	<ul style="list-style-type: none">• Updated List of Figures in TOC.
1 / 1	<ul style="list-style-type: none">• Removed Revision letter referenced to instruction manual.
2 / 12	<ul style="list-style-type: none">• Changed Revision number and date. Updated Warranty Section: Under Warranty, changed Revision Letter. Under General Section: removed first paragraph and replaced with “During the warranty period, T-API warrants each Product manufactured by T-API to be free from defects in material and workmanship under normal use and service. Expendable parts are excluded.”
2 / 13	<ul style="list-style-type: none">• Table 2-2, changed the BOX TEMP from 8-48°C to 8-40°C.• Table 2-2, changed the PMT TEMP from 7±2°C to 8±2°C.

PRINTED DOCUMENTS ARE UNCONTROLLED

THIS PAGE IS INTENTIONALLY LEFT BLANK



**TELEDYNE
INSTRUMENTS**
Advanced Pollution Instrumentation
A Teledyne Technologies Company

MANUAL ADDENDUM

MODEL 265A CHEMILUMINESCENCE OZONE ANALYZER

(ADDENDUM TO M200A INSTRUCTION MANUAL #02246)

**TELEDYNE INSTRUMENTS
ADVANCED POLLUTION INSTRUMENTATION DIVISION
9480 CARROLL PARK DRIVE
SAN DIEGO, CA 92121-2251**

**TOLL-FREE: 800-324-5190
FAX: 858-657-9816
TEL: 858-657-9800
E-MAIL: api-sales@teledyne.com
WEB SITE: www.teledyne-api.com**

THIS PAGE IS INTENTIONALLY LEFT BLANK

SAFETY MESSAGES

Your safety and the safety of others is very important. We have provided many important safety messages in this manual. Please read these messages carefully.

A safety message alerts you to potential hazards that could hurt you or others. Each safety message is associated with a safety alert symbol. These symbols are found in the manual and inside the instrument. The definition of these symbols is described below:



GENERAL WARNING/CAUTION: Refer to the instructions for details on the specific danger.



CAUTION: Hot Surface Warning



CAUTION: Electrical Shock Hazard



Technician Symbol: All operations marked with this symbol are to be performed by qualified maintenance personnel only.



Electrical Ground: This symbol inside the instrument marks the central safety grounding point for the instrument.

CAUTION

The analyzer should only be used for the purpose and in the manner described in this manual.

If you use the analyzer in a manner other than that for which it was intended, unpredictable behavior could ensue with possible hazardous consequences.



TABLE OF CONTENTS

SAFETY MESSAGES	I
TABLE OF CONTENTS.....	II
1 GETTING STARTED	1
1.0 Overview	1
1.1 Unpacking	1
1.2 Electrical and Pneumatic Connections.....	2
1.3 Initial Operation	7
1.4 Instrument Calibration	7
2 SPECIFICATIONS, WARRANTY.....	11
2.1 Specifications	11
2.2 Warranty.....	12
2.3 Test and Calibration Values	13
3 THE M265A OZONE ANALYZER.....	15
3.1 Principle of Operation	15
4 SOFTWARE FEATURES.....	19
5 MAINTENANCE	23
5.1 Maintenance Schedule	23

LIST OF FIGURES

FIGURE 1-1: REMOVAL OF SHIPPING SCREWS & CHECK FOR CORRECT POWER	3
FIGURE 1-2: M265A REAR PANEL	4
FIGURE 1-3: INLET AND EXHAUST VENTING RECOMMENDATIONS.....	5
FIGURE 1-4: V/F BOARD SWITCH SETTINGS.....	6
FIGURE 3-1: BLOCK DIAGRAM	16
FIGURE 3-2: PNEUMATIC DIAGRAM.....	17
FIGURE 4-1: SAMPLE MENU TREE	20
FIGURE 4-2: SETUP MENU TREE	21

LIST OF TABLES

TABLE 2.1: M265A SPECIFICATIONS.....	11
TABLE 2-2: FINAL TEST AND CALIBRATION VALUES.....	13
TABLE 5-1: PREVENTATIVE MAINTENANCE SCHEDULE	23

THIS PAGE IS INTENTIONALLY LEFT BLANK

1 GETTING STARTED

1.0 Overview

The Model 265A is a close derivative of the Model 200A Chemiluminescence NOx Analyzer. Because of this, the Model 200A Instruction manual continues to be valid as a reference manual covering the details of the instrument's components, procedures, etc. This manual addendum is intended as supplement to the model 200A manual (Teledyne API part number 02246) and provides an overview of the instrument and the details of the features and functions that are specific to the 265A.

1.1 Unpacking

CAUTION

Your safety and the safety of others is very important. We have provided many important safety messages in this manual.

Please read these messages carefully.

To avoid personal injury, always use two persons to lift and carry the Model 265A.



1. Before operation it is necessary to remove the shipping hold-down screws. Remove the instrument cover, then remove three screws (painted red) as shown in Figure 1-1.

Please remember if shipping or transporting the instrument to another site, the shipping screws must be re-installed to prevent damage to the sensor.

2. Also check for internal shipping damage, and generally inspect the interior of the instrument to make sure all circuit boards and other components are in good shape and properly seated.
3. Please check the voltage and frequency label on the serial number tag on the rear panel. Compare that to your local power before plugging the instrument into an outlet.

1.2 Electrical and Pneumatic Connections

1. See Figure 1-2 and Figure 1-3 to locate the rear panel electrical and pneumatic connections.
2. Attach the pump to the “Exhaust Out” port on the instrument rear panel. The exhaust from the pump should be vented to atmospheric pressure and out of the room, because of its NO content.
3. Attach the sample inlet line to the sample inlet port. The pressure of the sample gas at the inlet port should be at ambient pressure and constant. See Figure 1-3.
4. Attach a cylinder with 10,000 ppm $\pm 10\%$ of nitric oxide (NO) in nitrogen (N₂), with an appropriate pressure regulator, to the 1/8” SS port on the rear panel as shown in Figure 1-2. The cylinder’s pressure regulator should be set to deliver gas at 20 PSIG $\pm 10\%$.
5. Attach the analog output connections to a strip chart recorder and/or data-logger. See Figure 1-2 for connector pin-out definitions. See Figure 1-4 for V/F board switch settings. Factory default setting is 0-5 VDC.
6. Connect the power cord to the correct line voltage.

WARNING

**Analyzer Exhaust Contains Nitric Oxide Gas.
Vent pump exhaust to a well-ventilated area at atmospheric
pressure.**



WARNING

**Lethal voltages present inside case.
Do not operate with cover off during normal operation.
Before operation, check for correct input voltage and
frequency.
Do not operate without proper chassis grounding.
Do not defeat the ground wire on power plug.
Turn off analyzer power before disconnecting
electrical subassemblies.**



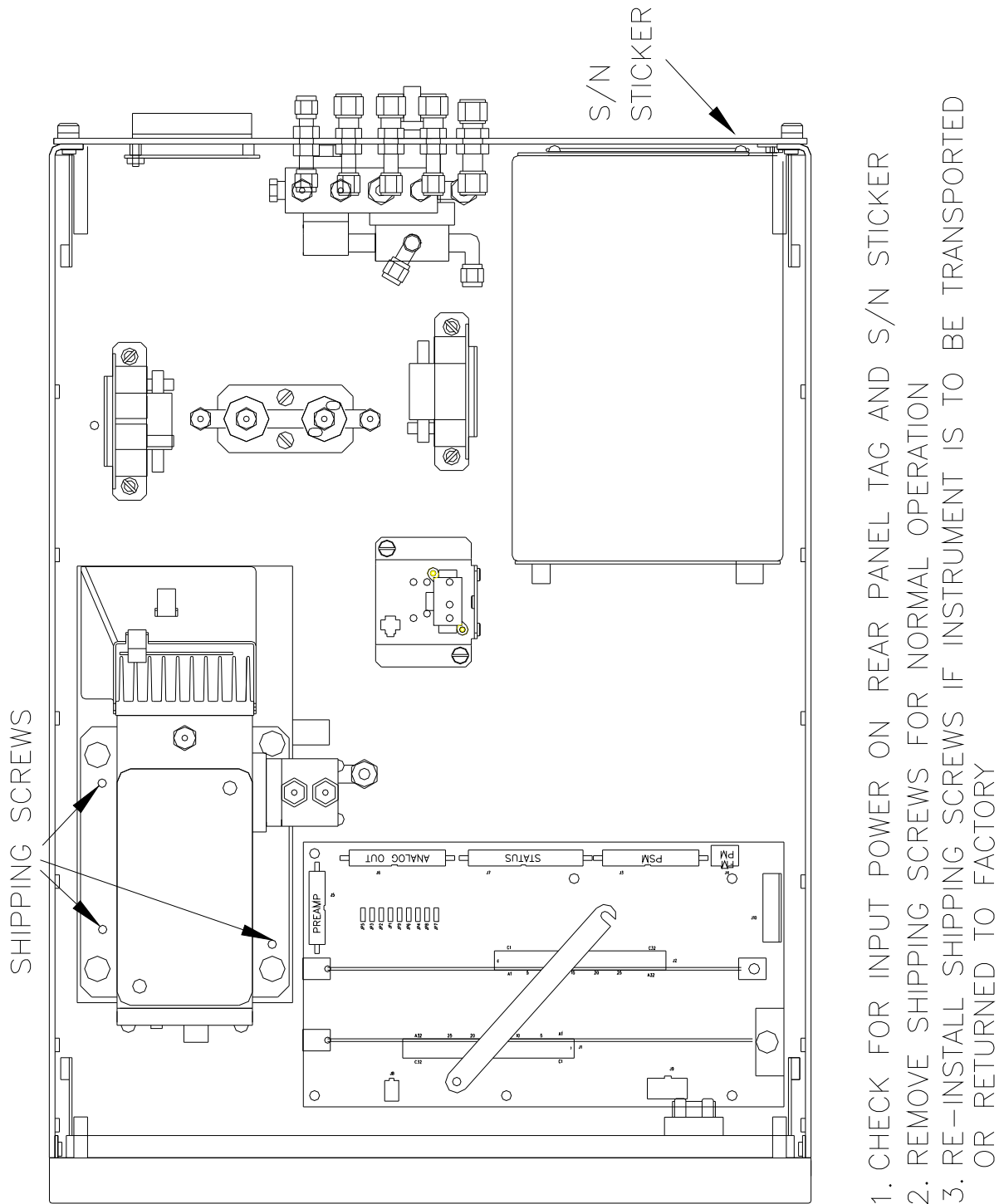

1. CHECK FOR INPUT POWER ON REAR PANEL TAG AND S/N STICKER
2. REMOVE SHIPPING SCREWS FOR NORMAL OPERATION
3. RE-INSTALL SHIPPING SCREWS IF INSTRUMENT IS TO BE TRANSPORTED OR RETURNED TO FACTORY

Figure 1-1: Removal of Shipping Screws & Check for Correct Power

**TAPI Model 265A Chemiluminescence Ozone Analyzer
Manual Addendum, Rev. B, DCN 5254**

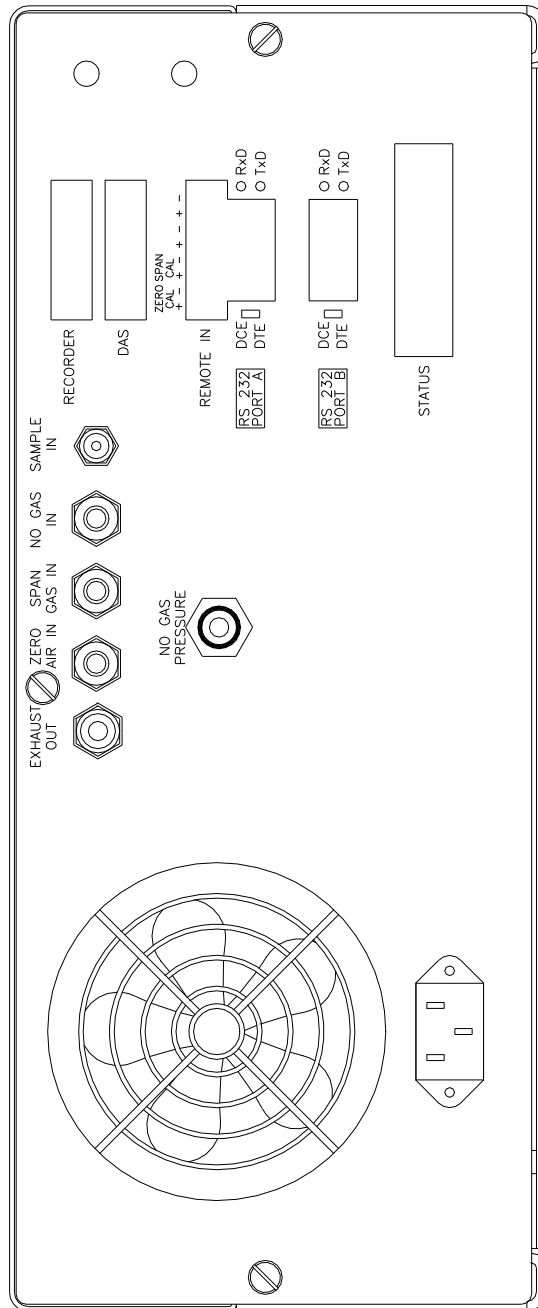

RECORDER AND DAS
PIN ASSIGNMENTS

PIN NO.	ASSIGNMENT
1	NOT USED
2	NOT USED
3	NOT USED
4	NOT USED
5	+ O3 CONC
6	- O3 CONC
7	+ TCHN
8	- TCHN

Figure 1-2: M265A Rear Panel

**TAPI Model 265A Chemiluminescence Ozone Analyzer
Manual Addendum, Rev. B, DCN 5254**

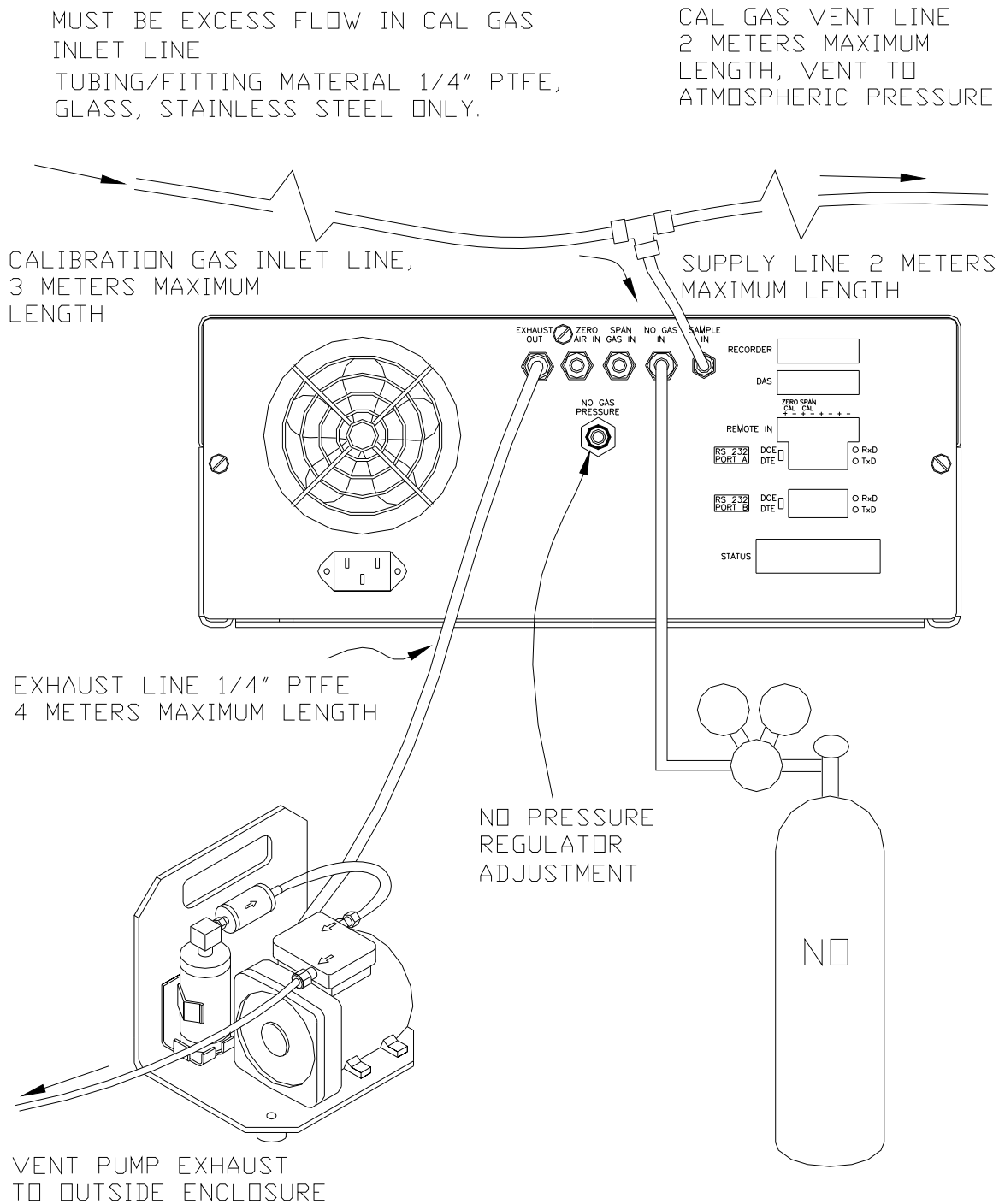

Figure 1-3: Inlet and Exhaust Venting Recommendations

TAPI Model 265A Chemiluminescence Ozone Analyzer Manual Addendum, Rev. B, DCN 5254

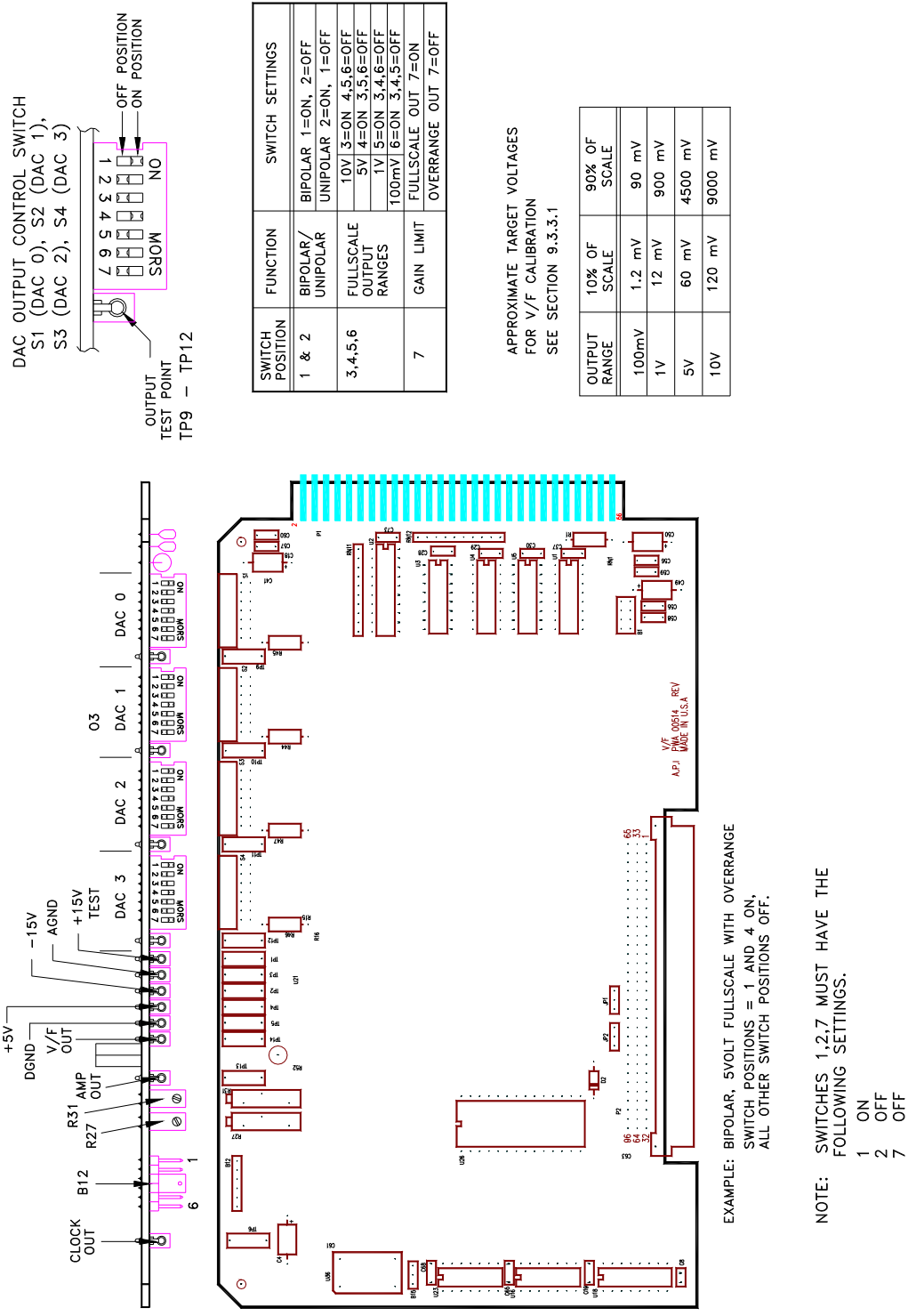

Figure 1-4: V/F Board Switch Settings

1.3 Initial Operation

1. Turn on the instrument power. The display should immediately light, showing the computer's memory configuration, then the instrument type - M265A. A diagram of the software menu trees can be found in Figure 4-1 and Figure 4-2.
2. On power-up, an internal solenoid valve will open allowing NO to flow. Check the NO FLOW test function on the front panel to verify that the flow is 5 cm³/min ±20%. If the flow is out of this range, check the inlet pressure at the rear panel and make sure that it is 20 psi, then adjust the pressure regulator on the rear panel until the flow is within range.
3. The M265A requires about 30 minutes for all internal components to heat to operating temperature. Many warning conditions are not displayed during this time, even though some parameters are out of specification. All warning messages are enabled after 30 minutes of operation.
4. When the instrument is warmed up, check the TEST functions. All of the readings should compare closely with those in Table 2-2.
5. Next is instrument calibration, which is shown in the following tables.

1.4 Instrument Calibration

Step 1 - Set the range, then enter the expected ozone span gas concentrations:

Step Number	Action	Comment
1.	Press CAL-CONC	This key sequence causes the M265A to prompt for the expected span concentration. Enter the span value by pressing the key under each digit until the expected value is set.
2.	Press ENTR	ENTR stores the expected span value. The internal formula is adjusted to compute this number when span gas concentration is input into the instrument.
5.	Press EXIT	Returns instrument to SAMPLE mode.
6.	Press SETUP-RNGE-MODE-SNGL	If necessary, you may want to change the range mode. Choices are either Single or AutoRange. Normally the instrument is shipped in Single range mode.
7.	Press SETUP-RNGE-SET	After the mode is set, you may want to set the maximum range value. The instrument is shipped with the range set at 500 ppb. This setting affects only your analog outputs, not the RS-232 output.

**TAPI Model 265A Chemiluminescence Ozone Analyzer
Manual Addendum, Rev. B, DCN 5254**

Step 2 - Calibrate the instrument: Zero/Span Calibration Procedure

Step Number	Action	Comment
1.	Input zero gas	Allow zero gas to enter the sample port on the rear of the instrument.
2.	Press CAL	The M265A enters the calibrate mode from sample mode.
3.	Wait 10 min	Wait for reading to stabilize at the zero value. If you wait less than 10 minutes the final zero value may drift. You may want to watch the STABIL test function (moving standard deviation) for its minimum value.
4.	Press ZERO	The ZERO button will be displayed once the concentration approaches zero.
5.	Press ENTR	Pressing ENTR zeroes the instrument and actually changes both offset and slope of the equations to calculate concentration.
6.	Press EXIT, input Span gas	M265A returns to the CAL menu. Now allow span gas to flow through the instrument.
7.	Wait 10 min	Wait for the O ₃ reading to stabilize at the span value (watch STABIL).
8.	Press SPAN	The SPAN button should be displayed once the concentration approaches the span value. In certain circumstances at low span gas concentrations both the ZERO and SPAN buttons will appear. Do not press ZERO again when running span gas!
9.	Press ENTR	Pressing ENTR to span the instrument actually changes the equations so that the concentration displayed is the same as the expected span concentration you entered above, thus spanning the instrument.
10.	Press EXIT	Pressing EXIT returns the instrument to SAMPLE mode.

Step 3 - Review Quality of calibration: Calibration Quality Check Procedure

**TAPI Model 265A Chemiluminescence Ozone Analyzer
Manual Addendum, Rev. B, DCN 5254**

Step Number	Action	Comment
1.	Scroll the TEST function menu until the O ₃ SLOPE is displayed.	The SLOPE value for O ₃ should be 1.0 ± 0.3 . If the SLOPE value is in the acceptable range the instrument will perform optimally.
2.	Scroll the TEST function menu until the O ₃ OFFS is displayed.	The M265A will display the OFFSET parameter for the O ₃ equation. This number should be near zero. A value of 0.0 ± 50 indicates calibration in the optimal range.

Step 4 - The M265A is now ready to measure sample gas.

THIS PAGE IS INTENTIONALLY LEFT BLANK

2 SPECIFICATIONS, WARRANTY

2.1 Specifications

Table 2.1: M265A Specifications

Ranges	In 1 ppb increments from 100 ppb to 20,000 ppb
Measurement Mode	Single range or AutoRange
Measurement Units	ppb, $\mu\text{g}/\text{m}^3$
Noise at zero	0.3 ppb per USEPA definition
Noise at span	<0.5% of reading RMS per USEPA definition above 100 ppb
Lower Detectable Limit	<0.6 ppb per USEPA definition
Zero Drift (24 hours) ¹	<1.0 ppb
Span Drift (24 hours) ¹	<1% of reading or 1 ppb, whichever is greater
Linearity	<1% of full scale
Precision	0.5% of reading
Lag Time	10 sec per USEPA definition
Rise/Fall Time	<20 sec per USEPA definition
Sample Flow Rate	500 \pm 50 cm^3/min
Reagent Gas	NO at 10,000 ppm \pm 10% and 20 psi pressure
Reagent Flow	5 \pm 1 cm^3/min
Temperature Range	5 – 40° C
Humidity Range	10-90% RH non-condensing
Temperature Coefficient	< 0.1% per °C
Voltage Coefficient	< 0.1% per V
Dimensions H x W x D	7" x 17" x 23.6" (18 cm x 43 cm x 61 cm)
Weight, Analyzer	36 lbs (16 kg)
Weight, Pump Pack	16 lbs (7 kg)
Power, Analyzer	100 V~ 50/60 Hz, 120 V~ 60 Hz, 220 V~ 50 Hz, 240 V~ 50 Hz, 200 W
Power, Analyzer ²	230 V~ 50 Hz, 2.5A
Power, Ext Pump	110 V~ 60 Hz, 220 V~ 50 Hz, 240 V~ 50 Hz, 295 W
Power, Ext Pump ²	230 V~ 50 Hz, 2.5A
Environmental ²	Installation Category (Over-voltage Category) II Pollution Degree 2
Analog Resolution	1 part in 2048 (11 bit) of selected voltage or current range
Analog Output Ranges	0-100 mV, 0-1, 5, 10 V, bipolar
Current Loop Option	4-20 mA, isolated
Status	12 status outputs from opto-isolators

1. At constant temperature and voltage.
2. Electrical ratings for CE Mark compliance.

2.2 Warranty

ADVANCED POLLUTION INSTRUMENTATION DIVISION (T-API) (02024D) (DCN 4473)

Prior to shipment, Teledyne API equipment is thoroughly inspected and tested. Should equipment failure occur, Teledyne API assures its customers that prompt service and support will be available.

COVERAGE

After the warranty period and throughout the equipment lifetime, Teledyne API stands ready to provide on-site or in-plant service at reasonable rates similar to those of other manufacturers in the industry. All maintenance and the first level of field troubleshooting is to be performed by the customer.

NON-API MANUFACTURED EQUIPMENT

Equipment provided but not manufactured by Teledyne API is warranted and will be repaired to the extent and according to the current terms and conditions of the respective equipment manufacturers warranty.

GENERAL

During the warranty period, T-API warrants each Product manufactured by T-API to be free from defects in material and workmanship under normal use and service. Expendable parts are excluded.

If a product fails to conform to its specifications within the warranty period, Teledyne API shall correct such defect by, in Teledyne API's discretion, repairing or replacing such defective product or refunding the purchase price of such product.

The warranties set forth in this section shall be of no force or effect with respect to any product: (i) that has been altered or subjected to misuse, negligence or accident, or (ii) that has been used in any manner other than in accordance with the instruction provided by API or (iii) not properly maintained.

THE WARRANTIES SET FORTH IN THIS SECTION AND THE REMEDIES THEREFORE ARE EXCLUSIVE AND IN LIEU OF ANY IMPLIED WARRANTIES OF MERCHANTABILITY, FITNESS FOR PARTICULAR PURPOSE OR OTHER WARRANTY OF QUALITY, WHETHER EXPRESSED OR IMPLIED. THE REMEDIES SET FORTH IN THIS SECTION ARE THE EXCLUSIVE REMEDIES FOR BREACH OF ANY WARRANTY CONTAINED HEREIN. TELEDYNE API SHALL NOT BE LIABLE FOR ANY INCIDENTAL OR CONSEQUENTIAL DAMAGES ARISING OUT OF OR RELATED TO THIS AGREEMENT OF TELEDYNE API'S PERFORMANCE HEREUNDER, WHETHER FOR BREACH OF WARRANTY OR OTHERWISE.

TERMS AND CONDITIONS

All units or components returned to Teledyne API should be properly packed for handling and returned freight prepaid to the nearest designated service center. After the repair, the equipment will be returned, freight prepaid.

2.3 Test and Calibration Values

Table 2-2: Final Test and Calibration Values

TEST Values	Observed Value	Units	Nominal Range	Reference Section
RANGE		ppb	10-20000	
NOISE		ppb	0.0 – 7.0	
SAMP FLW		cm ³ /min	500 ± 50	
NO FLOW		cm ³ /min	5 ± 1	
PMT		mV	0-5000	
AUTOZERO		mV	-10 to +50	
HVPS		V	400 – 850 constant	
DCPS		mV	2500 ± 200	
RCELL TEMP		°C	50 ± 2	
BOX TEMP		°C	8-40	
PMT TEMP		°C	8 ± 2	
RCEL PRES		IN-Hg-A	2 - 10 constant	
SAMP PRES		IN-Hg-A	20 - 30 constant	
NO PRES		PSIG	3 - 20 constant	
Electric Test & Optic Test				
Electric Test				
PMT Volts		mV	2000 ± 200	
O ₃ Conc		ppb	1000 ± 100	
OPTIC TEST				
PMT Volts		mV	2000 ± 200	
O ₃ Conc		ppb	1000 ± 100	

(table continued)

**TAPI Model 265A Chemiluminescence Ozone Analyzer
Manual Addendum, Rev. B, DCN 5254**

Table 2-2: Final Test and Calibration Values (Continued)

Parameter	Observed Value	Units	Nominal Range	Reference Section
O ₃ Span Conc		ppb	0.5 - 5000	
O ₃ Slope			1.0 ± 0.3	
O ₃ Offset		mV	± 25	
Noise at Zero		ppb	0.0 – 1.0	
Noise At Span		ppb	0.1 – 7.0	
Measured Flows				
Sample Flow		cm ³ /min	500 ± 50	
Factory Installed Options			Option Installed	
Power Voltage/Frequency				

PROM #

Serial #

Date

Technician

3 THE M265A OZONE ANALYZER

3.1 Principle of Operation

The Teledyne API Model 265A analyzer is designed to measure the concentration of ozone using the chemiluminescence reaction below. The signal comes from the light emitted by the gas phase reaction of nitric oxide (NO) and ozone (O₃) as follows:

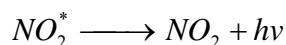
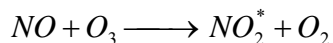

The reaction of ozone with NO results in electronically excited NO₂^{*} molecules as shown in the first equation. The excited NO₂^{*} molecules release their excess energy by emitting a photon *hv* and dropping to a lower energy level as shown in the second equation. It has been shown that the number of emitted photons is directly proportional to the O₃ concentration in the reaction cell.

Periodically, an AutoZero valve switches the sample stream to vacuum, allowing the reaction cell to be evacuated and the analyzer to read zero background. The AutoZero readings are subtracted from the concentration readings, which improves zero baseline stability.

**TAPI Model 265A Chemiluminescence Ozone Analyzer
Manual Addendum, Rev. B, DCN 5254**

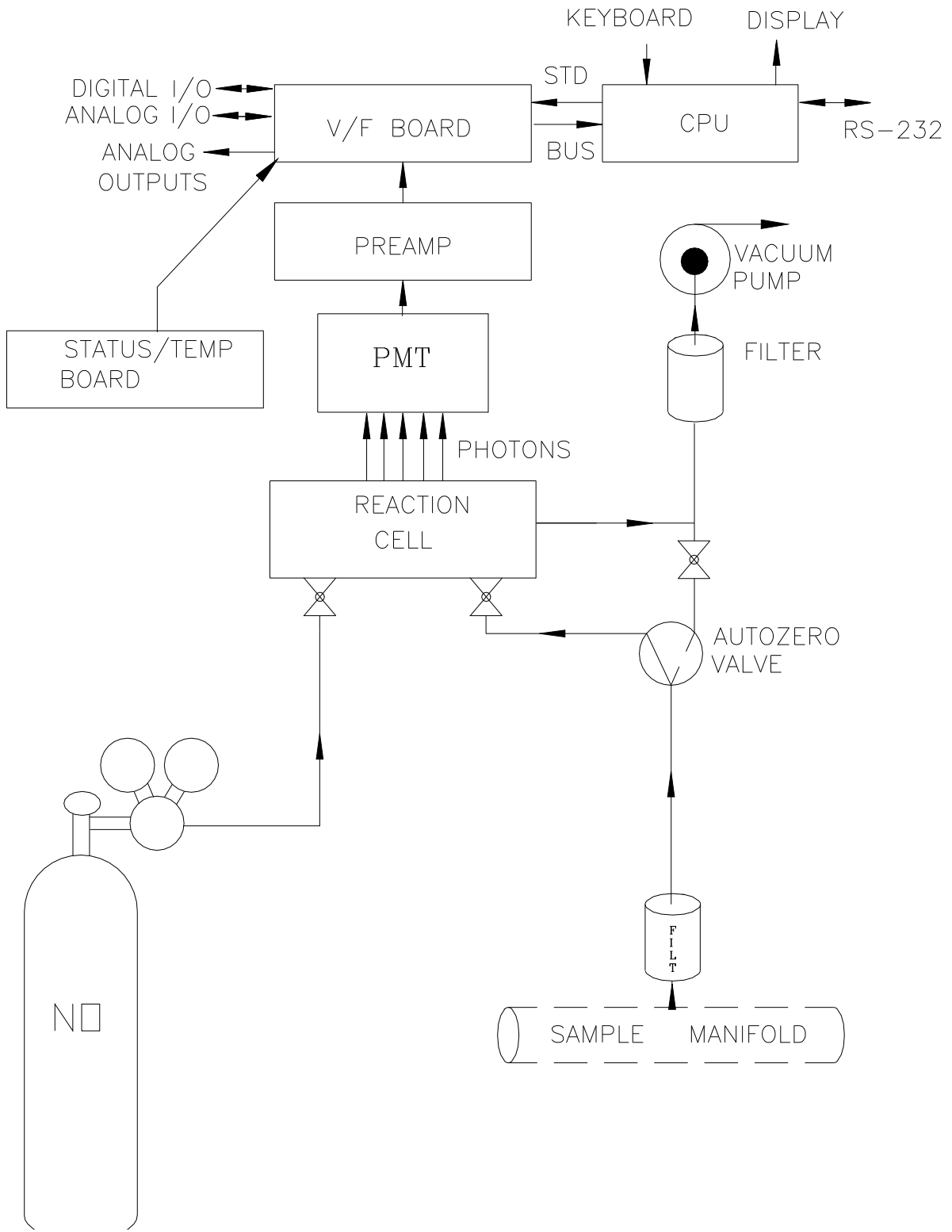

Figure 3-1: Block Diagram

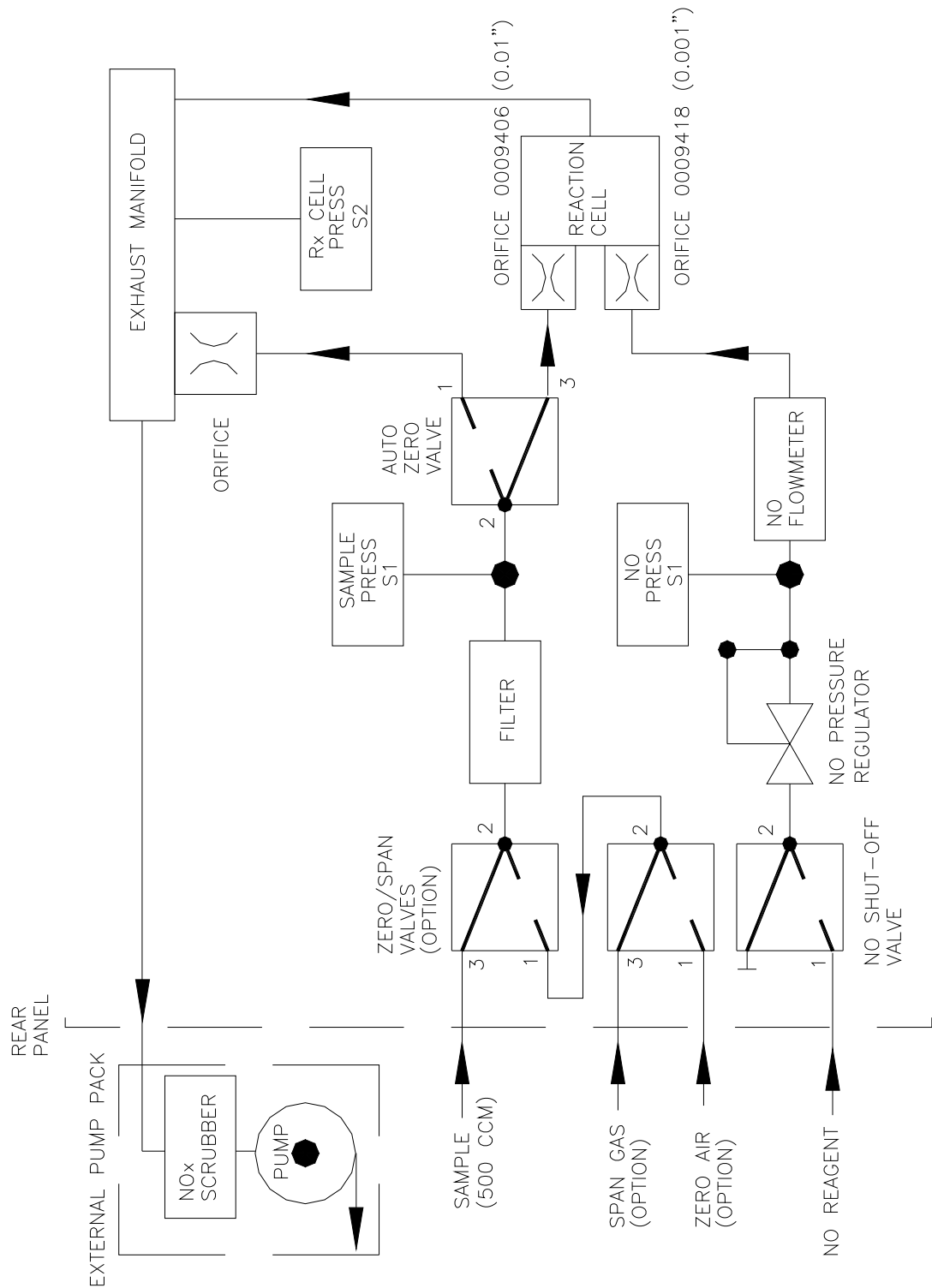

Figure 3-2: Pneumatic Diagram

THIS PAGE IS INTENTIONALLY LEFT BLANK

4 SOFTWARE FEATURES

The M265A software has two major operating modes. The SAMPLE mode is the normal mode when the instrument is taking data. The software menu that covers the SAMPLE mode is shown in Figure 4-1.

When the instrument is initially installed, a change of parameters is needed, or diagnostics is indicated, the SETUP menu is used, which is shown in Figure 4-2.

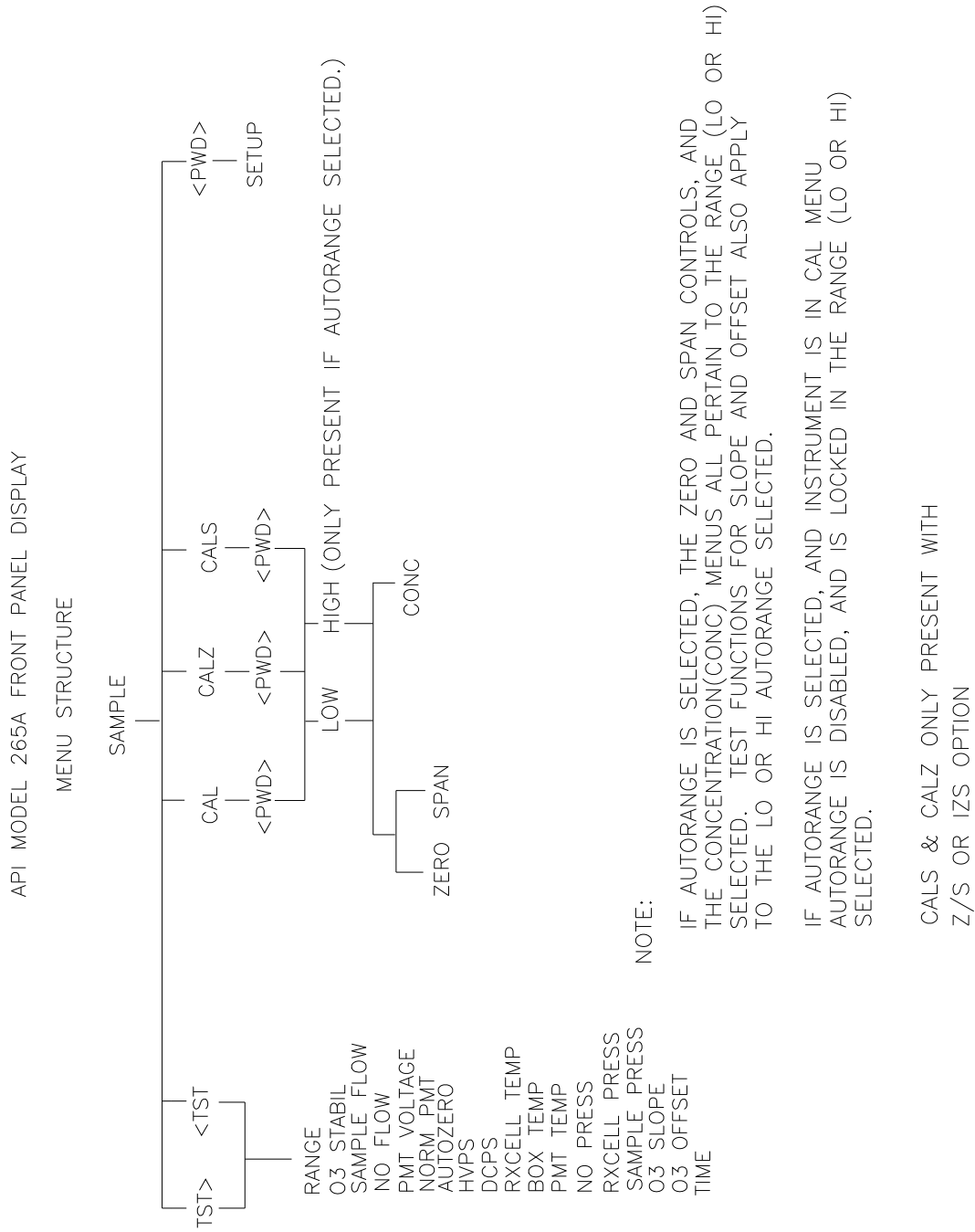

Figure 4-1: Sample Menu Tree

TAPI Model 265A Chemiluminescence Ozone Analyzer
Manual Addendum, Rev. B, DCN 5254

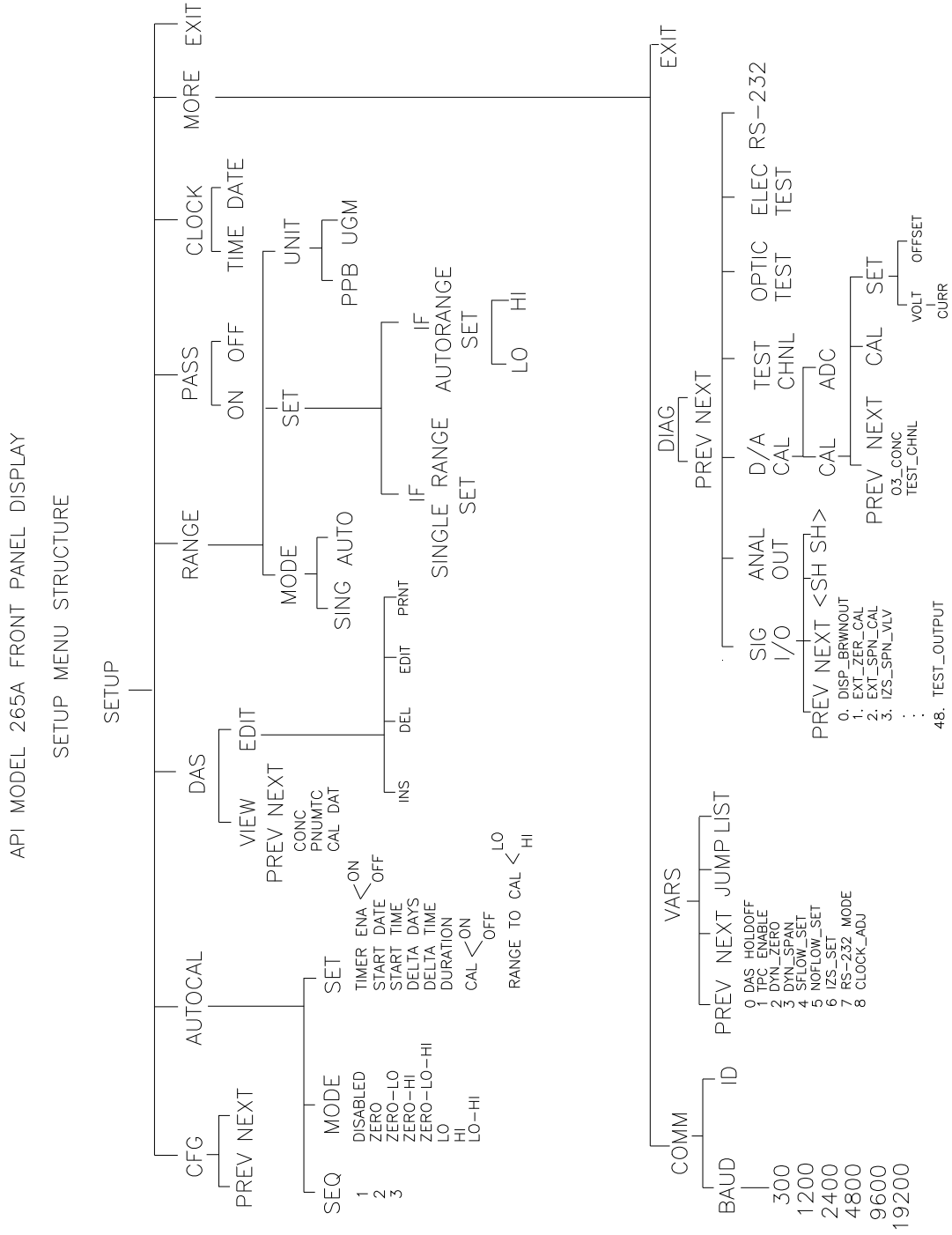

Figure 4-2: Setup Menu Tree

THIS PAGE IS INTENTIONALLY LEFT BLANK

5 MAINTENANCE

5.1 Maintenance Schedule

NOTE

The operations outlined in this chapter are to be performed by qualified maintenance personnel only.



Table 5-1: Preventative Maintenance Schedule

Item	Maintenance Interval	Reference Section
TEST functions	Review monthly	See M200A manual, Table 8-1
Zero/Span calibration	Annually or after repairs	See M200A manual, Table 8-1
Zero/Span checks	Daily	See M200A manual, Table 8-1
Particulate filter	Weekly as needed	See M200A manual, Table 8-1
Reaction cell window	Clean annually or as necessary	See M200A manual, Table 8-1
Nitric oxide flow	Check TEST function every month	Section 1-3 See also M200A manual, Table 8-1 (O ₃ flows)
Sample Flow	Check TEST function every month	See M200A manual, Table 8-1
Pneumatic lines	Examine every 12 months, clean if necessary.	See M200A manual, Table 8-1
Factory calibration	Calibrate each year or after repairs	See M200A manual, Table 8-1
Leak Check	Check every year or after other maintenance.	See M200A manual, Table 8-1
Reaction cell O-rings	Replace every 12 months	See M200A manual, Table 8-1
Other O-rings	Replace every 12 months	See M200A manual, Table 8-1

THIS PAGE IS INTENTIONALLY LEFT BLANK