



TELEDYNE API
Everywhereyoulook™



User Manual

Models T100, T100U, T100H ***UV Fluorescence SO₂ Analyzers***

with NumaView™ software

© TELEDYNE API (TAPI)
9970 CARROLL CANYON ROAD
SAN DIEGO, CALIFORNIA 92131-1106
USA

Toll-free Phone: +1 800-324-5190
Phone: +1 858-657-9800
Fax: +1 858-657-9816
Email: api-sales@teledyne.com
Website: <http://www.teledyne-api.com/>



T100, T100U, T100H

NOTICE OF COPYRIGHT

© 2022 Teledyne API (TAPI). All rights reserved.

TRADEMARKS

All trademarks, registered trademarks, brand names or product names appearing in this document are the property of their respective owners and are used herein for identification purposes only.



SAFETY MESSAGES

Important safety messages are provided throughout this manual for the purpose of avoiding personal injury or instrument damage. Please read these messages carefully. Each safety message is associated with a safety alert symbol and is placed throughout this manual; the safety symbols are also located inside the instrument. It is imperative that you pay close attention to these messages, the descriptions of which are as follows:



WARNING: Electrical Shock Hazard



HAZARD: Strong oxidizer



GENERAL WARNING/CAUTION: Read the accompanying message for specific information.



CAUTION: Hot Surface Warning



Do Not Touch: Touching some parts of the instrument without protection or proper tools could result in damage to the part(s) and/or the instrument.



Technician Symbol: All operations marked with this symbol are to be performed by qualified maintenance personnel only.



Electrical Ground: This symbol inside the instrument marks the central safety grounding point for the instrument.



T100, T100U, T100H

CAUTION

This product should only be installed, commissioned, and used strictly for the purpose and in the manner described in this manual. If you improperly install, commission, or use this instrument in any manner other than as instructed in this manual or by our Technical Support team, unpredictable behavior could ensue with possible hazardous consequences.

Such risks, whether during installation and commission or caused by improper installation/commissioning/use, and their possible hazardous outcomes include but are not limited to:



RISK	HAZARD
Liquid or dust/debris ingress	Electrical shock hazard
Improper or worn power cable	Electrical shock or fire hazard
Excessive pressure from improper gas bottle connections	Explosion and projectile hazard
Sampling combustible gas(es)	Explosion and fire hazard
Improper lift & carry techniques	Personal injury

Note that the safety of a system that may incorporate this product is the end user's responsibility.

For Technical Assistance regarding the use and maintenance of this instrument or any other Teledyne API product, contact Teledyne API's Technical Support Department:

Telephone: 800-324-5190
Email: api-techsupport@teledyne.com

or access any of the service options on our website at <http://www.teledyne-api.com/>



CONSIGNES DE SÉCURITÉ

Des consignes de sécurité importantes sont fournies tout au long du présent manuel dans le but d'éviter des blessures corporelles ou d'endommager les instruments. Veuillez lire attentivement ces consignes. Chaque consigne de sécurité est représentée par un pictogramme d'alerte de sécurité; ces pictogrammes se retrouvent dans ce manuel et à l'intérieur des instruments. Les symboles correspondent aux consignes suivantes :



AVERTISSEMENT : Risque de choc électrique



DANGER : Oxydant puissant



AVERTISSEMENT GÉNÉRAL / MISE EN GARDE : Lire la consigne complémentaire pour des renseignements spécifiques



MISE EN GARDE : Surface chaude



Ne pas toucher : Toucher à certaines parties de l'instrument sans protection ou sans les outils appropriés pourrait entraîner des dommages aux pièces ou à l'instrument.



Pictogramme « technicien » : Toutes les opérations portant ce symbole doivent être effectuées uniquement par du personnel de maintenance qualifié.



Mise à la terre : Ce symbole à l'intérieur de l'instrument détermine le point central de la mise à la terre sécuritaire de l'instrument.



T100, T100U, T100H

MISE EN GARDE

Ce produit ne doit être installé, mis en service et utilisé qu'aux fins et de la manière décrites dans le présent manuel. Si vous installez, mettez en service ou utilisez cet instrument de manière incorrecte autre que celle indiquée dans ce manuel ou sous la direction de notre équipe de soutien technique, un comportement imprévisible pourrait entraîner des conséquences potentiellement dangereuses.

Ce qui suit est une liste, non exhaustive, des risques et résultats dangereux possibles associés avec une mauvaise utilisation, une mise en service incorrecte, ou causés mauvaise commission.



RISQUE	DANGER
Pénétration de liquide ou de poussière/débris	Risque de choc électrique
Câble d'alimentation incorrect, endommagés ou usé	Choc électrique ou risque d'incendie
Pression excessive due à des connexions de bouteilles de gaz incorrectes	Risque d'explosion et d'émission de projectile
Échantillonnage de gaz combustibles	Risque d'explosion et d'incendie
Techniques de manutention, soulèvement et de transport inappropriées	Blessure corporelle

Notez que la sécurité d'un système qui peut incorporer ce produit est la responsabilité de l'utilisateur final.



WARRANTY

WARRANTY POLICY (02024J)

Teledyne API (TAPI), a business unit of Teledyne Instruments, Inc., provides that:

Prior to shipment, TAPI equipment is thoroughly inspected and tested. Should equipment failure occur, TAPI assures its customers that prompt service and support will be available. (For the instrument-specific warranty period, please refer to the “Limited Warranty” section in the Terms and Conditions of Sale on our website at www.teledyne-api.com).

COVERAGE

After the warranty period and throughout the equipment lifetime, TAPI stands ready to provide on-site or in-plant service at reasonable rates similar to those of other manufacturers in the industry. All maintenance and the first level of field troubleshooting are to be performed by the customer.

NON-TAPI MANUFACTURED EQUIPMENT

Equipment provided but not manufactured by TAPI is warranted and will be repaired to the extent and according to the current terms and conditions of the respective equipment manufacturer’s warranty.

PRODUCT RETURN

All units or components returned to Teledyne API should be properly packed for handling and returned freight prepaid to the nearest designated Service Center. After the repair, the equipment will be returned, freight prepaid.

The complete Terms and Conditions of Sale can be reviewed on our website

CAUTION – Avoid Warranty Invalidation



Failure to comply with proper anti-Electro-Static Discharge (ESD) handling and packing instructions and Return Merchandise Authorization (RMA) procedures when returning parts for repair or calibration may void your warranty. For anti-ESD handling and packing instructions please refer to the manual, Fundamentals of ESD, PN 04786, in its “Packing Components for Return to Teledyne API’s Customer Service” section. The manual can be downloaded from our website at <http://www.teledyne-api.com>. RMA procedures can also be found on our website.



T100, T100U, T100H

ABOUT THIS MANUAL

Support manuals, such as Fundamentals of Electro-Static Discharge (ESD), PN 04786, and NumaView™ Remote, PN 04892, are available on the TAPI website <http://www.teledyne-api.com>. The NumaView™ Software Addendum to T-Series Analyzer Manuals also may be helpful.

Note

We recommend that all users read this manual in its entirety before operating the instrument.

CONVENTIONS USED

In addition to the safety symbols as presented in the *Safety Messages* page, this manual provides *special notices* related to the careful and effective use of the instrument and related, pertinent information.

ATTENTION

COULD DAMAGE INSTRUMENT AND VOID WARRANTY
This special notice provides information to avoid damage to your instrument and possibly invalidate the warranty.

Important

IMPACT ON READINGS OR DATA
Provides information about that which could either affect accuracy of instrument readings or cause loss of data.

Note

Provides information pertinent to the proper care, operation or maintenance of the instrument or its parts.



TABLE OF CONTENTS

- Safety Messages..... ii
- Warranty vi
- Table of Contents viii
- List of Figuresxiii
- List of Tables..... xv
- 1. INTRODUCTION, SPECIFICATIONS, APPROVALS, & COMPLIANCE 17
 - 1.1. Specifications 18
 - 1.2. EPA Designation 20
 - 1.3. Compliance and Certifications 20
- 2. GETTING STARTED..... 21
 - 2.1. Unpacking..... 21
 - 2.1.1. Ventilation Clearance..... 22
 - 2.2. Instrument Layout..... 23
 - 2.2.1. Front Panel 23
 - 2.2.2. Rear Panel 24
 - 2.2.3. Internal Chassis 26
 - 2.3. Connections and Startup..... 29
 - 2.3.1. Electrical Connections..... 29
 - 2.3.1.1. Connecting Power 29
 - 2.3.1.2. Connecting Analog Outputs 30
 - 2.3.1.3. Current Loop Analog Outputs (Option 41) Setup 31
 - 2.3.1.4. Connecting the Status Outputs (Digital Outputs) 32
 - 2.3.1.5. Connecting the Control Inputs (Digital Inputs) 33
 - 2.3.1.6. Concentration Alarm Relay (Option 61)..... 34
 - 2.3.1.7. Connecting Communications Interfaces 34
 - 2.3.1.8. Connecting the External Pump (T100H)..... 40
 - 2.3.2. Pneumatic Connections 40
 - 2.3.2.1. Critical Tubing, Pressure, Venting and Exhaust Requirements..... 41
 - 2.3.2.2. Basic Connections from Calibrator 42
 - 2.3.2.3. Connections with Ambient Zero/Span (Z/S) Valves (Opt 50A) 44
 - 2.3.2.4. T100, T100U Connections w/Ambient Zero/Pressurized Span Valves (Opt 50E) ... 45
 - 2.3.2.5. T100, T100U Connections w/Zero Scrubber & Internal Zero Span (IZS) (Opt 50G) 46
 - 2.3.3. Pneumatic Flow Diagrams 49
 - 2.3.3.1. Pneumatic Flow for Basic Configuration 49
 - 2.3.3.2. Pneumatic Flow for Zero/Span Valves Option 50
 - 2.3.3.3. Pneumatic Flow for Ambient Zero/Pressurized Span Option 52
 - 2.3.3.4. Pneumatic Flow for Internal Zero/Span (IZS) Gas Generator Option 53
 - 2.3.3.5. Pneumatic Flow with O2 Sensor Option 54
 - 2.3.3.6. T100H Pneumatic Flow with Hydrocarbon Kicker Option 54
 - 2.3.4. Startup, Functional Checks and Calibration 55
 - 2.3.4.1 Startup..... 56
 - 2.3.4.2 Alerts: Warnings and Other Messages..... 57
 - 2.3.4.3 Functional Checks..... 58
 - 2.3.4.4 Calibration 58
 - 2.4 Menu Overview..... 59



T100, T100U, T100H

2.4.1	Home Page	60
2.4.2	Dashboard	62
2.4.3	Alerts	64
2.4.4	Calibration	65
2.4.5	Utilities.....	66
2.4.6	Setup.....	66
2.5	Setup Menu: Features/Functions Configuration	67
2.5.1	Setup>Data Logging (Data Acquisition System, DAS).....	67
2.5.1.1	Configuring Trigger Types: Periodic	69
2.5.1.2	Configuring Trigger Types: Conditional	70
2.5.1.3	Downloading DAS (Data Acquisition System) Data	70
2.5.2	Setup>Events	71
2.5.2.1	Editing or Deleting Events	72
2.5.2.2	Using Events as Triggers for Data Logging	73
2.5.3	Setup>Dashboard	73
2.5.4	Setup>AutoCal (with Valve Option).....	74
2.5.5	Setup>Vars.....	74
2.5.6	Setup>Homescreen	75
2.5.7	Setup>Digital Outputs	76
2.5.8	Setup>Analog Outputs	77
2.5.8.1	Manual Calibration of Voltage Range Analog Outputs	79
2.5.8.2	Manual Adjustment of Current Range Analog Outputs	80
2.5.9	Setup>Instrument.....	81
2.5.10	Setup>Comm (Communications)	82
2.5.10.1	COM1/COM2.....	82
2.5.10.2	TCP Port1.....	83
2.5.10.3	TCP Port2.....	83
2.5.10.4	TCP Port3.....	83
2.5.10.5	Network Settings.....	83
2.6	Transferring Configuration to Other Instruments	84
3	COMMUNICATIONS AND REMOTE OPERATION	86
3.4	Data Terminal/Communication Equipment (DTE DCE).....	86
3.5	Modes, Baud Rate and Serial Communication	86
3.5.1	Serial Communication: RS-232	87
3.5.2	Serial Communication: RS-485 (Option).....	87
3.6	Ethernet	87
3.7	Communications Protocols	88
3.7.1	MODBUS	88
3.7.1.1	MODBUS Com Port Configuration	88
3.7.2	Hessen	90
3.7.2.1	Hessen Com Port Configuration	90
3.7.2.2	Hessen Settings Configuration	91
3.7.2.3	Hessen Gas List Configuration.....	94
4	CALIBRATION.....	95
4.4	Important Precalibration Information.....	95



T100, T100U, T100H

4.4.1	Calibration Requirements.....	95
4.4.2	Zero Air	96
4.4.3	Calibration (Span) Gas	96
4.4.4	Span Gas for Multipoint Calibration.....	97
4.4.5	Physical Range Measurements.....	97
4.4.6	Interferents.....	98
4.4.7	Permeation Tube Options	98
4.4.8	Data Recording Devices.....	98
4.5	Calibration Procedures	99
4.5.1	Calibration and Check Procedures for Basic Configuration.....	99
4.5.1.1	Zero Calibration Check and Actual Calibration	101
4.5.1.2	Span Calibration Check and Actual Calibration.....	101
4.5.2	Calibration and Check Procedures with Valve Options Installed	102
4.5.2.1	Use of Zero/Span Valve with Remote Contact Closure.....	103
4.6	Automatic Zero/Span Cal/Check (Auto Cal).....	104
4.7	Calibration Quality Analysis	106
4.8	EPA Protocol Calibration	107
5	MAINTENANCE AND SERVICE	108
5.1	Maintenance Schedule	108
5.2	Predictive Diagnostics.....	110
5.3	Operational Health Checks	111
5.4	Software/Firmware Updates	111
5.4.1	Remote Updates.....	111
5.4.2	Manual Reload/Update Procedures.....	112
5.4.3	Touchscreen Display Calibration (for earlier instruments)	113
5.5	Time Zone Changes.....	114
5.6	Hardware Maintenance Procedures.....	115
5.6.1	Replacing the Sample Particulate Filter	115
5.6.2	Changing/Removing the IZS Permeation Tube.....	116
5.6.3	Changing the External Zero Air Scrubber	117
5.6.4	Servicing Critical Flow Orifices.....	118
5.6.5	Checking for Light Leaks	120
5.6.6	Checking for Pneumatic Leaks.....	121
5.6.6.1	Simple Vacuum Leak and Pump Check	121
5.6.6.2	Detailed Pressure Leak Check	121
5.6.6.3	Performing Flow Checks/Calibrations.....	122
5.6.7	Checking the Hydrocarbon Scrubber (<i>Kicker</i>).....	123
5.6.7.1	Checking the Scrubber for Leaks.....	123
5.7	Service and Troubleshooting	124
5.7.1	Fault Diagnosis with Alerts	125
5.7.2	Fault Diagnosis With Dashboard Functions.....	129
5.7.3	Using the Diagnostic Signal I/O Functions.....	131
5.7.4	Using the Internal Electronic Status LEDs.....	131
5.7.4.1	CPU Status Indicator.....	131
5.7.4.2	Relay PCA Watchdog and Status LEDs	132
5.7.4.3	T100U Sync Demod PCA LEDs	133
5.7.5	Flow Problems	134
5.7.5.1	Sample Flow is Zero or Low.....	134



T100, T100U, T100H

5.7.5.2	High Flow.....	135
5.7.5.3	Sample Flow is Zero or Low but Analyzer Reports Correct Flow	135
5.7.6	Calibration Problems	136
5.7.6.1	Negative Concentrations.....	136
5.7.6.2	No Response.....	136
5.7.6.3	Unstable Zero and Span	137
5.7.6.4	Inability to Span - Deactivated SPAN Button	137
5.7.6.5	Inability to Zero - Deactivated ZERO Button	138
5.7.6.6	Non-Linear Response	138
5.7.6.7	Discrepancy Between Analog Output and Display.....	138
5.7.7	Other Performance Problems	139
5.7.7.1	Excessive Noise	139
5.7.7.2	Slow Response.....	139
5.7.8	Subsystem Check for Troubleshooting.....	139
5.7.8.1	AC Main Power	140
5.7.8.2	DC Power Supply	141
5.7.8.3	I ² C Bus.....	141
5.7.8.4	LCD/Display Module.....	142
5.7.8.5	Relay PCA	142
5.7.8.6	Motherboard.....	142
5.7.8.7	Pneumatic Pressure / Flow Sensor Assembly	144
5.7.8.8	CPU.....	144
5.7.8.9	RS-232 Communications	144
5.7.8.10	Photomultiplier Tube (PMT) Sensor Module	146
5.7.8.11	PMT Temperature Control PCA.....	147
5.7.8.12	Internal Span Gas (IZS) Generator and Valve Options	148
5.7.8.13	Temperature Sensors	149
5.7.9	Service Procedures	150
5.7.9.1	Disk-On-Module Replacement Procedure	150
5.7.9.2	Sensor Module Repair and Cleaning	151
5.7.9.3	T100 PMT Sensor Hardware Calibration ("Factory Cal").....	166
5.7.9.4	T100U PMT Sensor Hardware Calibration ("Factory Cal").....	168
5.7.9.5	Removing / Replacing the Relay PCA from the Instrument	169
5.8	Frequently Asked Questions	170
5.9	Technical Assistance	171
6	PRINCIPLES OF OPERATION.....	172
6.1	Sulfur Dioxide (SO ₂) Sensor Principles of operation	172
6.1.1	SO ₂ Ultraviolet Fluorescence Measurement Principle	172
6.1.2	The UV Light Path	175
6.1.3	UV Source Lamp	177
6.1.4	The Reference Detector	177
6.1.5	The PMT.....	177
6.1.6	UV Lamp Shutter & PMT Offset.....	178
6.1.7	Optical Filters.....	178
6.1.7.1	UV Source Optical Filter	178
6.1.7.2	PMT Optical Filter.....	179



T100, T100U, T100H

6.1.8	Optical Lenses.....	180
6.1.9	Measurement Interferences	181
6.1.9.1	Direct Interference.....	181
6.1.9.2	UV Absorption by Ozone	181
6.1.9.3	Dilution.....	181
6.1.9.4	Third Body Quenching.....	181
6.1.9.5	Light Pollution	182
6.2	Oxygen (O ₂) Sensor Principles of Operation	182
6.2.1	Paramagnetic Measurement of O ₂	182
6.2.2	O ₂ Sensor Operation within the T100 Analyzer.....	183
6.3	Carbon Dioxide (CO ₂) Sensor Principles of Operation	184
6.3.1	NDIR Measurement of CO ₂	184
6.3.2	CO ₂ Operation within the T100 Analyzer	185
6.3.3	Electronic Operation of the CO ₂ Sensor	185
6.4	Pneumatic Operation.....	186
6.4.1	Sample Gas Flow.....	186
6.4.2	Flow Rate Control	186
6.4.2.1	Critical Flow Orifice	186
6.4.2.2	Sample Particulate Filter	188
6.4.3	Hydrocarbon Scrubber (Kicker)	188
6.4.4	Pneumatic Sensors	189
6.4.4.1	Sample Pressure Sensor	189
6.4.4.2	Sample Flow Sensor	189
6.5	Electronic Operation	190
6.5.1	Overview.....	190
6.5.2	CPU	192
6.5.3	Sensor Module.....	192
6.5.3.1	Sample Chamber Heating Circuit	195
6.5.4	Photo Multiplier Tube (PMT).....	195
6.5.5	PMT Cooling System.....	197
6.5.5.1	Thermoelectric Cooler (TEC)	197
6.5.5.2	TEC Control Board	198
6.5.6	T100 PMT Preamplifier Board	198
6.5.7	T100U Sync Demod Board.....	200
6.5.8	Pneumatic Sensor Board	201
6.5.9	Relay Board.....	201
6.5.9.1	Heater Control.....	202
6.5.9.2	Heaters for IZS Option (JP6) and AC Configuration.....	203
6.5.10.1	Valve Control.....	204
6.5.10.2	Status LEDs and Watchdog Circuitry	204
6.5.11	Motherboard	204
6.5.11.1	A to D Conversion.....	204
6.5.11.2	Sensor Inputs.....	205
6.5.11.3	Thermistor Interface	205



T100, T100U, T100H

- 6.5.12 Analog Outputs..... 206
- 6.5.13 External Digital I/O 206
- 6.5.14 I²C Data Bus 206
- 6.5.15 Power Up Circuit..... 206
- 6.5.16 Power Supply/Circuit Breaker 206
- 6.5.17 Front Panel Touchscreen/Display Interface 209
 - 6.5.17.1 LVDS Transmitter Board 210
 - 6.5.17.2 Front Panel Touchscreen/Display Interface PCA 210
- 6.6 Software Operation 210
 - 6.6.1 Adaptive Filter 211
 - 6.6.2 Calibration - Slope and Offset 211
 - 6.6.3 Temperature/Pressure Compensation (TPC) 212
 - 6.6.4 Internal Data Acquisition System (DAS) 212
- Glossary..... 213

LIST OF FIGURES

- Figure 2-1. Front Panel Layout 23
- Figure 2-2. Rear Panel Layout, Base Unit (options include additional pneumatic ports) 24
- Figure 2-3. T100 Internal Chassis Layout, Basic 26
- Figure 2-4. T100U Internal Chassis Layout 27
- Figure 2-5. T100H Internal Chassis Layout, Basic Unit 28
- Figure 2-6. Analog Output Connector 30
- Figure 2-7. Current Loop Option Installed on the Motherboard 31
- Figure 2-8. Status Output Connector for Digital Outputs 32
- Figure 2-9. Energizing the Control Inputs 33
- Figure 2-10. Concentration Alarm Relay..... 34
- Figure 2-11. Rear Panel Connector Pin-Outs for RS-232 Mode 35
- Figure 2-12. Default Pin Assignments for CPU COM Port Connector (RS-232) 36
- Figure 2-13. Jumper and Cables for Multidrop Mode 38
- Figure 2-14. RS-232 Multidrop PCA Option Host/Analyzer Interconnect Diagram 39
- Figure 2-15. Gas Line Connections from Gas Dilution Calibrator – Basic Configuration 42
- Figure 2-16. Gas Line Connections from Bottled Span Gas – Basic Configuration 42
- Figure 2-17. Example of T100H Pneumatic Connections..... 43
- Figure 2-18. Gas Line Connections with Z/S Valves Option (OPT 50A) 44
- Figure 2-19. Gas Line Connection w/Ambient Zero/Pressurized Span Valves Option (OPT 50E) 45
- Figure 2-20. Gas Line Connection w/Zero Scrubber and IZS Option (OPT 50G) 46
- Figure 2-21. Pneumatic Connections for Precision Calibration when IZS Generator Present 47
- Figure 2-22. T100, T100U Pneumatics, Basic Configuration 49
- Figure 2-23. T100H Pneumatics, Basic Configuration..... 50
- Figure 2-24. T100, T100U Pneumatics with Zero/Span Valves Option..... 50
- Figure 2-25. T100H Pneumatics with Zero/Span Valves Option 51
- Figure 2-26. T100, T100U Pneumatics with Ambient Zero/Pressurized Span Valves Option 52
- Figure 2-27. T100, T100U Pneumatics with IZS Option 53
- Figure 2-28. Pneumatics with O₂ Sensor 54
- Figure 2-29. Hydrocarbon Scrubber (Kicker) – T100H Option 86D 55
- Figure 2-30. 2T100H Pneumatic Flow with Hydrocarbon Kicker Option 86D 55
- Figure 2-31. Status Screens at Startup..... 56
- Figure 2-32. Home Page Example..... 56
- Figure 2-33. Viewing Active Alerts Page..... 57
- Figure 2-34. Sample Dashboard Page 58
- Figure 2-35. User Interface Orientation 60



T100, T100U, T100H

Figure 2-36. Concentration and Stability Graph (top) and Meter Graph (bottom)	61
Figure 2-37. Dashboard Page	62
Figure 2-38. Navigating to the Active Alerts Page	64
Figure 2-39. Active Alerts Cleared	65
Figure 2-40. Utilities>Alerts Log of Active and Past Alerts and Events	65
Figure 2-41. Datalog Configuration, New Log Page	67
Figure 2-42. Datalog Configuration, Existing Log	67
Figure 2-43. Creating a New Data Log	68
Figure 2-44. Datalog Periodic Trigger Configuration	69
Figure 2-45. Datalog - Conditional Trigger Configuration	70
Figure 2-46. DAS Download Page	70
Figure 2-47. Events List	71
Figure 2-48. Event Configuration	71
Figure 2-49. Configured Event Sample	72
Figure 2-50. Edit or Delete an Event	72
Figure 2-51. Dashboard Display and Configuration	73
Figure 2-52. Homescreen Configuration	75
Figure 2-53. Digital Outputs Setup	76
Figure 2-54. Analog Output Configuration Example	77
Figure 2-55. Analog Outputs Group Calibration Screen	78
Figure 2-56. Analog Outputs Manual Calibration Screen (AOUT2 Example)	78
Figure 2-57. Setup for Checking / Calibrating DCV Analog Output Signal Levels	79
Figure 2-58. Setup for Checking / Calibration Current Output Signal Levels	80
Figure 2-59. Alternative Setup Using 250Ω Resistor for Checking Current Output Signal Levels	81
Figure 2-60. Communications Configuration, Network Settings	83
Figure 2-61. Configuration Transfer	84
Figure 3-1. MODBUS via Ethernet	88
Figure 3-2. MODBUS via Serial Communication (example)	89
Figure 3-3. Serial Communication, Setting Hessen Protocol	90
Figure 3-4. Hessen Gas List Configuration	94
Figure 4-1. Setup for Manual Calibration without Z/S Valve or IZS Option	100
Figure 4-2. Multi-Point Calibration Page	101
Figure 4-3. Setup for Manual Calibration Check with Z/S Valve or IZS Option	102
Figure 4-4. Zero and Span Calibration Screens	103
Figure 4-5. Auto Cal Page	104
Figure 5-1. Report Generation Page	111
Figure 5-2. Remote Update Page	111
Figure 5-3. Manual Update Page (and other utilities)	112
Figure 5-4. Touchscreen Calibration Page	113
Figure 5-5. Time Zone Change Requirements	114
Figure 5-6. Replacing the Particulate Filter	115
Figure 5-7. Critical Flow Orifice Assembly	118
Figure 5-8. Critical Flow Orifice and Vacuum Manifold Assembly	119
Figure 5-9. Flow Calibration Menu	123
Figure 5-10. Simple Leak Check Fixture	123
Figure 5-11. Hydrocarbon Scrubber Leak Check Setup	124
Figure 5-12. CPU Status Indicator	131
Figure 5-13. Relay PCA Status LED Locations	132
Figure 5-14. Location of Relay Board Power Configuration Jumper	140
Figure 5-15. Typical Set Up of Status Output Test	143
Figure 5-16. Sensor Module Wiring and Pneumatic Fittings	152
Figure 5-17. Sensor Module Mounting Screws	153
Figure 5-18. Hex Screw Between Lens Housing and Sample Chamber	154
Figure 5-19. UV Lens Housing / Filter Housing	154
Figure 5-20. PMT UV Filter Housing Disassembled	155
Figure 5-21. Disassembling the Shutter Assembly	156



T100, T100U, T100H

Figure 5-22. Shutter Assembly	158
Figure 5-23. UV Lamp Adjustment.....	159
Figure 5-24. Location of UV Reference Detector Potentiometer	160
Figure 5-25. T100 Sensor Assembly	162
Figure 5-26. T100U Sensor Assembly.....	164
Figure 5-27. Pre-Amplifier Board Layout	167
Figure 5-28. Relay PCA with AC Relay Retainer In Place.....	169
Figure 5-29. Relay PCA Mounting Screw Locations.....	169
Figure 6-1. UV Absorption.....	173
Figure 6-2. T100, T100U UV Light Path	176
Figure 6-3. T100H UV Light Path.....	176
Figure 6-4. Source UV Lamp Construction	177
Figure 6-5. Excitation Lamp UV Spectrum Before/After Filtration	178
Figure 6-6. PMT Optical Filter Bandwidth	179
Figure 6-7. Effects of Focusing Source UV in Sample Chamber.....	180
Figure 6-8. Oxygen Sensor - Principles of Operation	183
Figure 6-9. CO ₂ Sensor Principles of Operation	184
Figure 6-10. CO ₂ Sensor Option PCA Layout and Electronic Connections.....	185
Figure 6-11. Flow Control Assembly & Critical Flow Orifice	187
Figure 6-12. Location of Critical Flow Orifice in T100, T100U	187
Figure 6-13. Location of Critical Flow Orifice in T100H	188
Figure 6-14. Hydrocarbon Scrubber (Kicker).....	189
Figure 6-15. Electronic Block Diagram	190
Figure 6-16. CPU Board.....	192
Figure 6-17. T100 Sensor Module	193
Figure 6-18. T100U Sensor Module.....	193
Figure 6-19. T100 Sample Chamber	194
Figure 6-20. T100U Sample Chamber.....	195
Figure 6-21. Basic PMT Design	196
Figure 6-22. PMT Cooling System.....	197
Figure 6-23. PMT Preamp Block Diagram	199
Figure 6-24. Sensor Block Diagram.....	200
Figure 6-25. Relay PCA Layout (P/N 045230100).....	201
Figure 6-26. Relay PCA P/N 045230100 with AC Relay Retainer in Place.....	202
Figure 6-27. Typical Jumper Set (JP2) Set Up of Heaters	203
Figure 6-28. T100, T100U Power Distribution Block Diagram.....	207
Figure 6-29. T100H Power Distribution Block Diagram	208
Figure 6-30. Front Panel and Display Interface Block Diagram.....	209
Figure 6-31. Basic Software Operation.....	210

LIST OF TABLES

Table 1-1. Specifications.....	18
Table 1-2. O ₂ Sensor Option Specifications	19
Table 1-3. CO ₂ Sensor Option Specifications.....	19
Table 2-1. Ventilation Clearance.....	22
Table 2-2. Rear Panel Description	25
Table 2-3. Analog Output Pin Assignments	30
Table 2-4. Status Output Pin Assignments	33
Table 2-5. Control Input Pin Assignments	34
Table 2-6. Zero/Span and Sample/Cal Valve Operating States	51
Table 2-7. Valve Operating States for Ambient Zero/Pressurized Span Option.....	52
Table 2-8. IZS Valve Option Operating States.....	53
Table 2-9. Menu Overview	59
Table 2-10. Utilities Submenu Descriptions.....	66



T100, T100U, T100H

Table 2-11. Typical Variables with Descriptions	74
Table 2-12. Analog Output Voltage/Current Range	78
Table 2-13. Voltage Tolerances	79
Table 2-14. Current Loop Output Check	81
Table 2-15. Setup>Instrument Menu	81
Table 2-16. COM1/COM2 Configuration	82
Table 2-17. LAN/Ethernet Configuration Properties	84
Table 3-1. Ethernet Status Indicators	87
Table 3-2. Teledyne API's Hessen Protocol Response Modes	91
Table 3-3. T100, T100U Hessen Status Flags and Default Bit Assignments	92
Table 3-4. T100H Hessen Status Flags and Default Bit Assignments	93
Table 3-5. Hessen Gas List Definitions	94
Table 4-1. Auto Cal States	105
Table 4-2. Auto Cal Setup Combinations	105
Table 4-3. Auto Cal Programming Sequence Execution	106
Table 4-4. Calibration Data Quality Evaluation	106
Table 5-1. Maintenance Schedule	109
Table 5-2. Predictive Uses for Dashboard Functions	110
Table 5-3. Warning Alerts, Fault Conditions and Possible Causes	126
Table 5-4. Dashboard Functions - Possible Causes for Out-of-Range Values	130
Table 5-5. Relay PCA Watchdog and Status LED Failure Indications	133
Table 5-6. Relay PCA Status LED Failure Indications	133
Table 5-7. DC Power Test Point and Wiring Color Code	141
Table 5-8. DC Power Supply Acceptable Levels	141
Table 5-9. Relay PCA Control Devices	142
Table 5-10. UV Lamp Signal Troubleshooting	159
Table 6-1. Power Configuration for Optional Heaters (JP6)	203

Appendix A – MODBUS Registers

Appendix B – Interconnect Wiring Diagram



1. INTRODUCTION, SPECIFICATIONS, APPROVALS, & COMPLIANCE

The Teledyne API Model T100, T100U (trace level), and T100H (high range) UV Fluorescence SO₂ Analyzers are microprocessor controlled analyzers that determine the concentration of sulfur dioxide (SO₂), in a sample gas drawn through the instrument's sample chamber where it is exposed to ultraviolet light, which causes any SO₂ present to fluoresce. The instrument measures the amount of fluorescence to determine the amount of SO₂ present in the sample gas. The T100 and T100U models are typically used in monitoring ambient air quality, while the T100H model has applications in continuous emission monitoring systems in industrial settings.

These instruments' exceptional stability is achieved with the use of an optical shutter to compensate for sensor drift and a reference detector to correct for changes in UV lamp intensity. Additionally, an advanced optical design combined with a special scrubber, called a "kicker" that removes hydrocarbons (which fluoresce similarly to SO₂), to prevent inaccuracies caused by interferences.

Calibration is performed in software that stores SO₂ concentration measurements made when specific, known concentrations of SO₂ are supplied to the analyzer. The microprocessor uses these calibration values along with other performance parameters such as the sensor offset, UV lamp intensity, amount of stray light present, and sample gas temperature and pressure measurements to compute the final SO₂ concentration.

Proprietary software allows configurable data acquisition capability that can be triggered conditionally or periodically, enabling operators to perform predictive diagnostics and enhanced data analysis by tracking parameter trends. Reports can be downloaded onto a USB flash drive or via the I/O ports. Operators can also view real-time graphing with one touch of the interface screen.



T100, T100U, T100H

1.1. SPECIFICATIONS

Table 1-1. Specifications

PARAMETER		SPECIFICATION		
		T100	T100U	T100H
Range (Physical Analog Output) selectable, dual range supported	Min:	0-50 ppb Full Scale	0-5 ppb Full Scale	0-10 ppm Full Scale
	Max:	0-20,000 ppb Full Scale	0-20,000 ppb Full Scale	0-5,000 ppm Full Scale
Measurement Units (selectable)		ppb, ppm, µg/m ³ , mg/m ³	ppb, ppm, µg/m ³ , mg/m ³	ppm, µg/m ³
Zero Noise ¹		< 0.2 ppb (RMS)	25 ppt RMS (50 ppt RMS with 360 nm filter installed)	< 0.1 ppm (RMS)
Span Noise ¹		< 0.5% of reading (RMS) above 50 ppb	< 0.5% of reading (RMS) above 5 ppb	< 1% of reading (RMS) above 10 ppm
Lower Detectable Limit ²		< 0.4 ppb	50 ppt	< 0.2 ppm
Zero Drift/24 hours		< 0.5 ppb (at constant temperature and voltage)	< 0.2 ppb (< 4 ppb with 360 nm filter installed) (at constant temperature and voltage)	< 1 ppm
Span Drift/24 hours (at constant temperature and voltage)		< 0.5% of Full Scale (at constant temperature and voltage)	< 0.5% of Full Scale (at constant temperature and voltage)	< 0.5% of Full Scale (at constant temperature and voltage)
Response Time ¹		< 120 seconds to 95%	< 170 seconds to 95%	< 40 seconds to 95%
Linearity		1% of full scale	1% of full scale	1% of full scale
Precision		0.5% of reading above 50 ppb	0.5% of reading	0.5% of reading above 10 ppm
Sample Flow Rate		650 cc/min ± 10%	650 cc/min ± 10%	700 cc/min ± 10%
AC Power		<u>Rating & Typical Power Usage</u>	<u>Rating & Typical Power Usage</u>	<u>Rating & Typical Power Usage</u>
		110-120 V~, 60 Hz, 30A, 165W 220-240 V~, 50/60 Hz, 30A, 140W	110-120 V~, 60 Hz, 30A, 135W 220-240 V~, 50/60 Hz, 30A, 155W	110-120 V~, 60Hz, 30A, 105W 220-240 V~, 50/60 Hz, 30A, 105W
Analog Output Ranges		10V, 5V, 1V, 0.1V (selectable)		
Recorder Offset		± 10%		
Standard I/O		1 Ethernet: 10/100Base-T 2 RS-232 (300 – 115,200 baud) 2 USB device ports 8 opto-isolated digital status outputs (7 defined, 1 spare) 6 opto-isolated digital control inputs (4 defined, 2 spare) 4 analog outputs		
Optional I/O		1 USB com port 1 RS485 4 digital alarm outputs Multidrop RS232 3 4-20mA current outputs		
Dimensions H x W x D		7" x 17" x 23.5" (178mm x 432 mm x 597 mm)		
Weight		T100: 31 lbs (14 kg); 35.7 lbs (16.2 kg) with internal pump	T100U: 45 lbs (20.5 kg) with internal pump	T100H: 31 lbs (14 kg) External pump: 15 lbs (7 kg)
		Operating Temperature Range: 5 - 40 °C (with US EPA equivalency for T100, T100U)		
Humidity Range		0-95% RH non-condensing		
Environmental Conditions		Installation Category (Over voltage Category) II Pollution Degree 2 Intended for Indoor Use Only at Altitudes ≤ 2000m		

¹ As defined by the US EPA.

² Defined as twice the zero noise level by the US EPA.

All specifications are based on constant conditions.



T100, T100U, T100H

Table 1-2. O₂ Sensor Option Specifications

PARAMETER	DESCRIPTION
Ranges	0-1% to 0-100% user selectable. Dual ranges and auto-ranging supported.
Zero Noise ¹	<0.02% O ₂
Lower Detectable Limit ²	<0.04% O ₂
Zero Drift (24 hours) ³	<± 0.02% O ₂
Zero Drift (7 days)	<± 0.05% O ₂
Span Noise ¹	<± 0.05% O ₂
Span Drift (7 days)	<± 0.1% O ₂
Accuracy	(intrinsic error) <± 0.1% O ₂
Linearity	<± 0.1 % O ₂
Temp Coefficient	<± 0.05% O ₂ /°C,
Rise and Fall Time	<60 seconds to 95%

¹ As defined by the USEPA

² Defined as twice the zero noise level by the USEPA

³ Note: zero drift is typically <± 0.1% O₂ during the first 24 hrs of operation

Table 1-3. CO₂ Sensor Option Specifications

PARAMETER	DESCRIPTION
Ranges	0-1% to 0-20% user selectable. Dual ranges and auto-ranging supported.
Zero Noise ¹	<0.02% CO ₂
Zero Drift (24 hours)	<± 0.02% CO ₂
Zero Drift (7 days)	<± 0.05% CO ₂
Span Noise ¹	<± 0.1% CO ₂
Span Drift (7 days)	<± 0.1% CO ₂
Lower Detectable Limit ²	<0.04% CO ₂
Accuracy	<± (0.02% CO ₂ + 2% of reading)
Linearity	<± 0.1% CO ₂
Temperature Coefficient	<± 0.01% CO ₂ /°C
Rise and Fall Time	<60 seconds to 95%

¹ As defined by the USEPA

² Defined as twice the zero noise level by the USEPA



T100, T100U, T100H

1.2. EPA DESIGNATION

Teledyne API's Model T100 and Model T100U Fluorescent SO₂ Analyzers are officially designated as US EPA Federal Equivalent Method Number EQSA-0495-100 for sulfur dioxide measurement. The official List of Designated Reference and Equivalent Methods is published in the U.S. Federal Register: <http://www3.epa.gov/ttn/amtic/criteria.html>, and specifies the instrument's settings and configurations.

1.3. COMPLIANCE AND CERTIFICATIONS

This product is CE compliant and adheres to the Low Voltage and ElectroMagnetic Compatibility directives.

For any other certifications, please refer to this product's specifications sheet on our website.



2. GETTING STARTED

This section addresses unpacking, connecting, and initializing the instrument, getting an overview of the menu system, and setting up/configuring the functions.

2.1. UNPACKING



CAUTION - GENERAL SAFETY HAZARD

To avoid personal injury, always use two persons and proper lift and carry techniques to move/relocate the analyzer.

ATTENTION

COULD DAMAGE INSTRUMENT AND VOID WARRANTY

Printed Circuit Assemblies (PCAs) are sensitive to electro-static discharges too small to be felt by the human nervous system. Failure to use Electro-Static Discharge (ESD) protection when working with electronic assemblies will void the instrument warranty. Refer to the manual, Fundamentals of ESD, PN 04786, which can be downloaded from our website at <http://www.teledyne-api.com>.

ATTENTION

COULD DAMAGE INSTRUMENT AND VOID WARRANTY

Do not operate this instrument without first removing dust plugs from SAMPLE and EXHAUST ports on the rear panel.

Note

Teledyne API recommends that you store shipping containers and materials for future use if/when the instrument should be returned to the factory for repair and/or calibration service. See Warranty statement in this manual and Return Merchandise Authorization (RMA) on our Website at <http://www.teledyne-api.com>.

Verify that there is no apparent external shipping damage. If damage has occurred, please advise the shipper first, then Teledyne API.

Included with your instrument is a printed record of the final performance characterization performed on your instrument at the factory. This record, titled Final Test and Validation Data Sheet, is an important quality assurance and calibration record and should be placed in the quality records file for this instrument.



T100, T100U, T100H

With no power to the unit, carefully remove the top cover of the instrument and check for internal shipping damage by carrying out the following steps:

1. Carefully remove the top cover and check for internal shipping damage.
 - a. Remove the side-panel screws that hold the cover in place.
 - b. Slide the cover backward until it clears the instrument's front bezel.
 - c. Lift the cover straight up.
2. Inspect the interior of the instrument to ensure all circuit boards and other components are intact and securely seated.
3. Check the connectors of the various internal wiring harnesses and pneumatic hoses to ensure they are firmly and securely seated.
4. Verify that all of the optional hardware ordered with the unit has been installed. These are listed on the paperwork accompanying the instrument.



WARNING – ELECTRICAL SHOCK HAZARD

Never disconnect or reconnect PCAs, wiring harnesses or electronic subassemblies while instrument is under power.

2.1.1. VENTILATION CLEARANCE

Whether the instrument is set up on a bench or installed in a rack, be sure to leave sufficient ventilation clearance.

Table 2-1. Ventilation Clearance

AREA	MINIMUM REQUIRED CLEARANCE
Back of the instrument	10 cm / 4 in
Sides of the instrument	2.5 cm / 1 in
Above and below the instrument	2.5 cm / 1 in



2.2. INSTRUMENT LAYOUT

This section illustrates the front and rear panels and the internal chassis layout.

2.2.1. FRONT PANEL

The front panel (Figure 2-1) includes two USB ports for peripheral device connections, which can be used with mouse and keyboard as alternatives to the touchscreen interface, or with flash drive for uploads/downloads (devices not included).

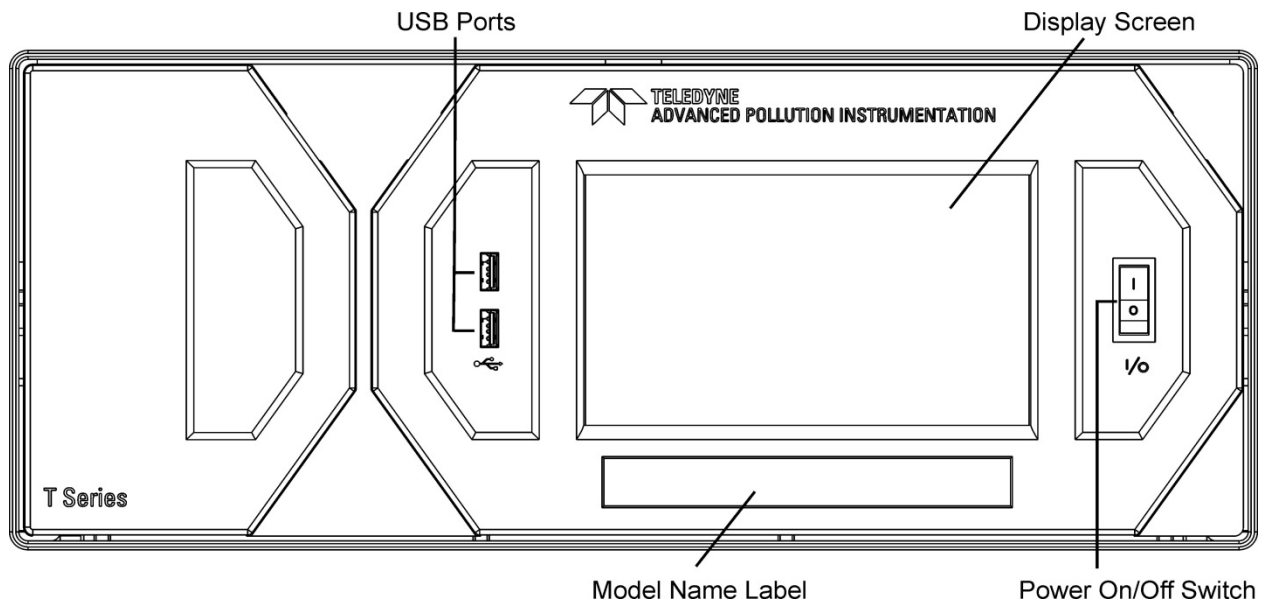

Figure 2-1. Front Panel Layout



T100, T100U, T100H

2.2.2. REAR PANEL

Figure 2-2 shows the layout of the rear panel.

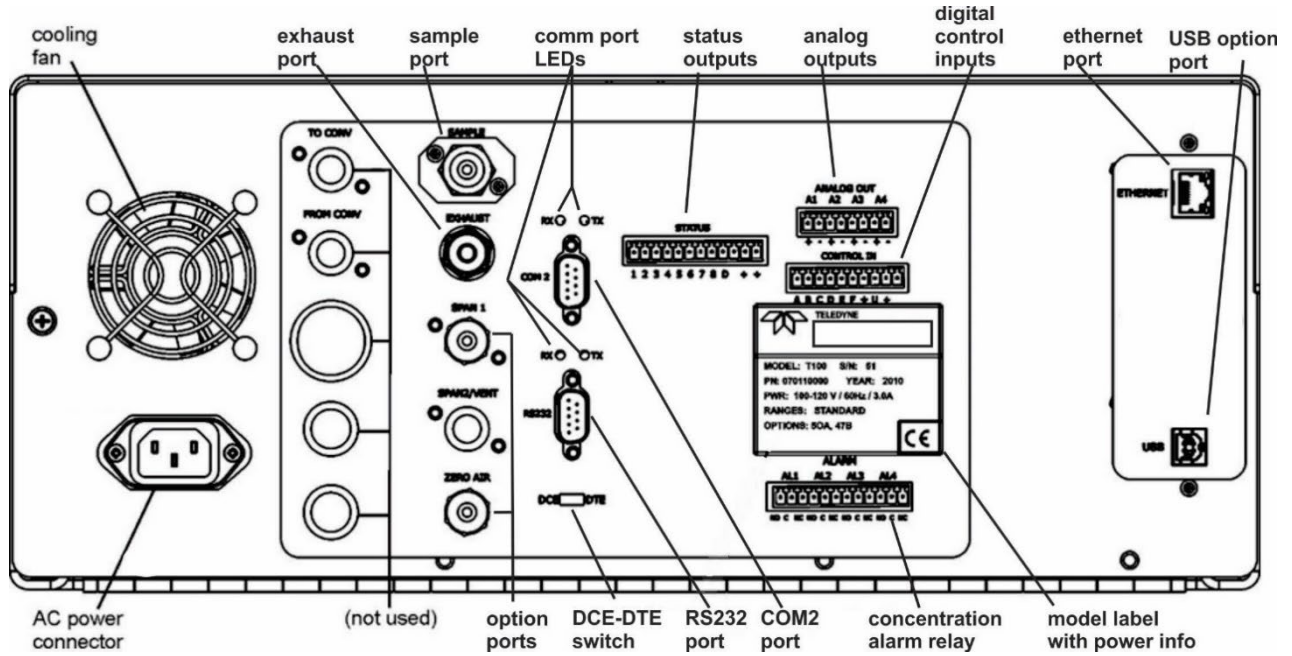



Figure 2-2. Rear Panel Layout, Base Unit (options include additional pneumatic ports)



T100, T100U, T100H

Table 2-2. Rear Panel Description

COMPONENT	FUNCTION
cooling fan	Pulls ambient air into chassis through side vents and exhausts through rear.
 AC power connector	Connector for three-prong cord to apply AC power to the analyzer. CAUTION! The cord's power specifications (specs) MUST comply with the power specs on the analyzer's rear panel Model number label
Model/specs label	Identifies the analyzer model number and provides power specs
TO CONV	(not used in this model)
FROM CONV	(not used in this model)
SAMPLE	Connect a gas line from the source of sample gas here. Calibration gases can also enter here on units without zero/span/shutoff valve options installed.
EXHAUST	T100, T100U: Connect an exhaust gas line of not more than 10 meters long from here to outside the shelter or immediate area surrounding the instrument. The line must be ¼" tubing or greater. T100H: Connect ¼" PTFE tubing from here to external pump's inlet port, and not more than 10 meters long from pump's outlet port to outside the shelter or immediate area surrounding the instrument.
SPAN 1	On units with zero/span/shutoff valves option installed, connect a gas line to the source of calibrated span gas here.
SPAN2/VENT	Used as a second cal gas input line when instrument is configured with zero/span valves and a dual gas option, or as a cal gas vent line when instrument is configured with a pressurized span option (<i>Call factory for details</i>).
ZERO AIR	Internal Zero Air: On units with zero/span/shutoff valves option installed but no internal zero air scrubber attach a gas line to the source of zero air here.
RX TX	LEDs indicate receive (RX) and transmit (TX) activity when blinking.
COM 2	Serial communications port for RS-232 or RS-485.
RS-232	Serial communications port for RS-232 only.
DCE DTE	Switch to select either data terminal equipment or data communication equipment during RS-232 communication.
STATUS	For outputs to devices such as Programmable Logic Controllers (PLCs).
ANALOG OUT	For voltage or current loop outputs to a strip chart recorder and/or a data logger.
CONTROL IN	For remotely activating the zero and span calibration modes.
ALARM	Option for concentration alarms and system warnings.
ETHERNET	Connector for network or Internet remote communication, using Ethernet cable.
USB (option)	Connector for direct connection to laptop computer, using USB cable.
Label	Includes voltage and frequency specifications.



T100, T100U, T100H

2.2.3. INTERNAL CHASSIS

Figure 2-3 shows the T100 internal chassis basic configuration. Figure 2-5 shows the T100U internal chassis configuration. Their PMT housings differ, and the T100U has a sync demodulator PCA.

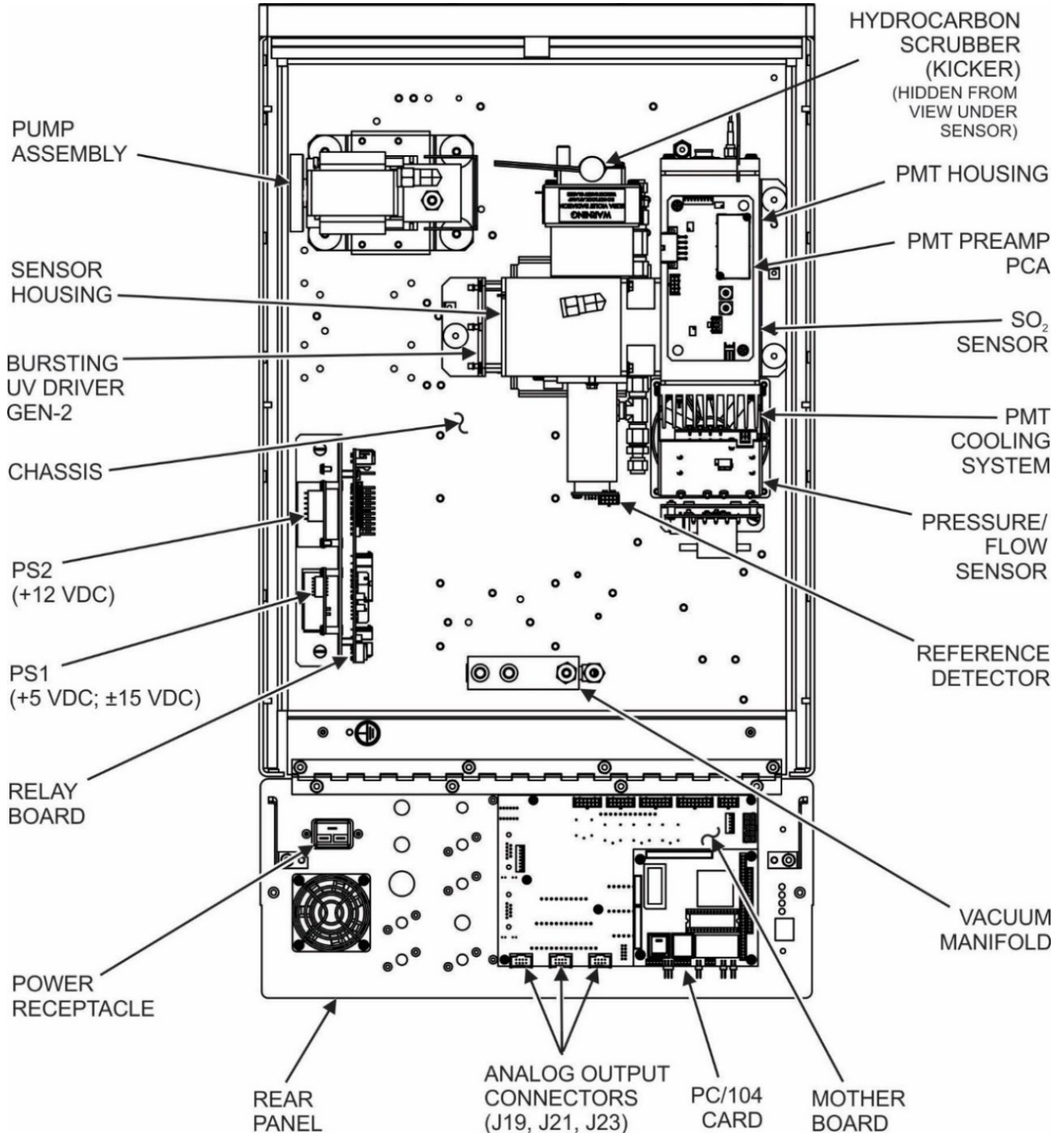

Figure 2-3. T100 Internal Chassis Layout, Basic



T100, T100U, T100H

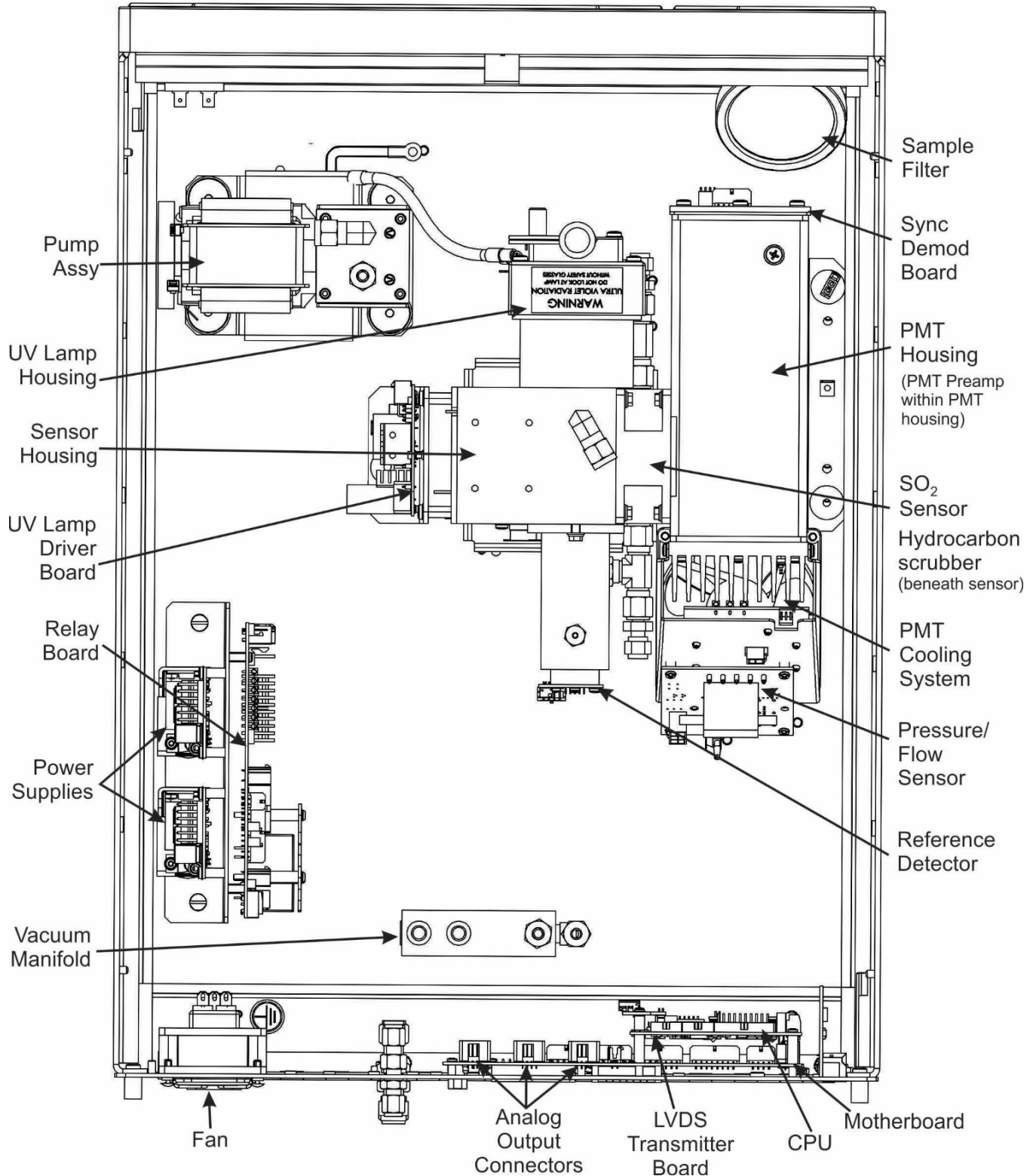

Figure 2-4. T100U Internal Chassis Layout



T100, T100U, T100H

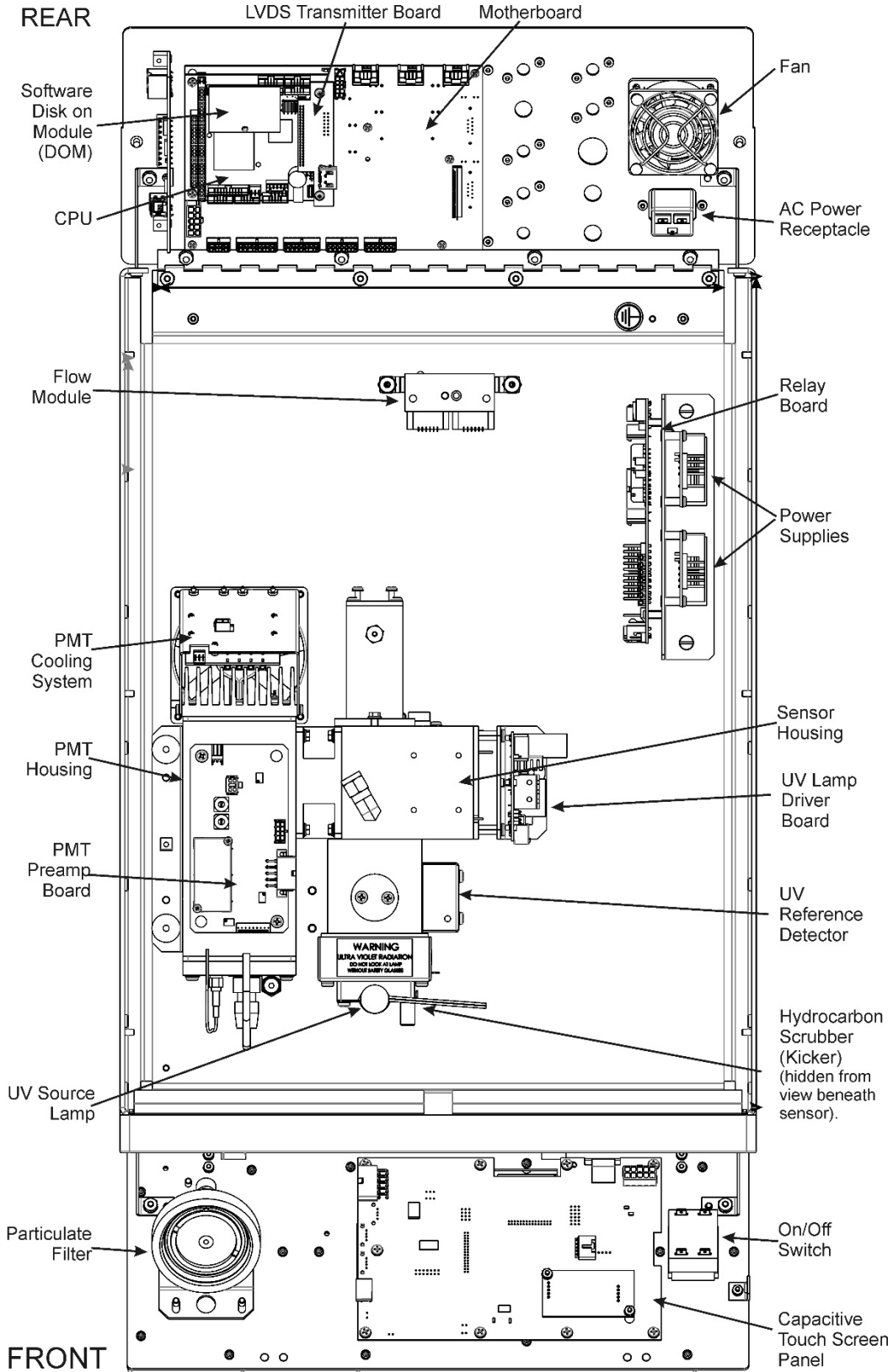

Figure 2-5. T100H Internal Chassis Layout, Basic Unit



2.3. CONNECTIONS AND STARTUP

This section presents the electrical (Section 2.3.1) and pneumatic (Section 2.3.1.8) connections for setting up and preparing the instrument for operation (Section 2.3.3).

2.3.1. ELECTRICAL CONNECTIONS

Note

To maintain compliance with EMC standards, cable length must be go greater than 3 meters for all I/O connections.

Teledyne API recommends that you store shipping containers and materials for future use if/when the instrument should be returned to the factory for repair and/or calibration service.



WARNING – Electrical Shock Hazard

- High Voltages are present inside the instrument's case.
- Power connection must have functioning ground connection.
- Do not defeat the ground wire on power plug.
- Turn off instrument power before disconnecting or connecting electrical subassemblies.
- Do not operate with cover off.



CAUTION – Avoid Damage to the Instrument

Ensure that the AC power voltage matches the voltage indicated on the instrument's model/specs label before plugging it into line power.

2.3.1.1. CONNECTING POWER

Attach the power cord between the instrument's AC power connector and a power outlet capable of carrying at least the rated current at your AC voltage range. It is important to adhere to all safety and cautionary messages, and ensure that the outlet is equipped with a functioning earth ground.



2.3.1.2. CONNECTING ANALOG OUTPUTS

The rear panel Analog Output channels A1 through A4 can be mapped to reflect various operating values in the analyzer, including concentration values, temperatures, pressures, etc. These mappings are not configured by default and must be set by the user.

An optional Current Loop output (Section 2.3.1.3) is available for A1, A2 and A3 only.

To access these signals attach a strip chart recorder and/or data-logger to the appropriate analog output connections on the rear panel of the analyzer.

Configure through the Setup>Analog Outputs menu (Section 2.5.8)

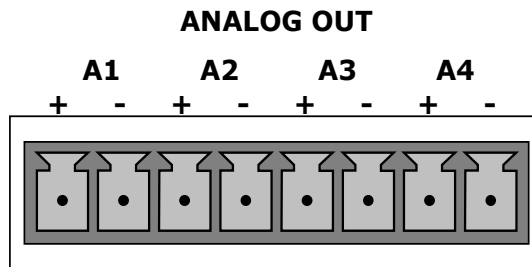

Figure 2-6. Analog Output Connector

Table 2-3. Analog Output Pin Assignments

PIN	ANALOG OUTPUT	SIGNAL OUT	STANDARD VOLTAGE OUTPUT	CURRENT LOOP OPTION
1	A1	User-selected through the Setup>Analog Outputs menu.	V +	I Out +
2			Ground	I Out -
3	A2		V +	I Out +
4			Ground	I Out -
3	A3		V +	I Out +
4			Ground	I Out -
7	A4		V +	Not Available
8			Ground	Not Available



2.3.1.3. CURRENT LOOP ANALOG OUTPUTS (OPTION 41) SETUP

If your analyzer had this option installed at the factory, there are no further connections to be made. Otherwise, it can be installed as a retrofit for each of the analog outputs. This option converts the DC voltage analog output to a current signal with 0-20 mA output current, which can be scaled to any set of limits within that 0-20 mA range. However, most current loop applications call for either 2-20 mA or 4-20 mA range. All current loop outputs have a +5% over-range. Ranges with the lower limit set to more than 1 mA (e.g., 2-20 or 4-20 mA) also have a -5% under-range.

Figure 2-7 provides installation instructions and illustrates a sample configuration of one current output combined with two voltage outputs. Next are instructions for converting current loop analog outputs to standard 0-to-5 VDC outputs. To calibrate or adjust these outputs use the Setup>Analog Outputs menu (Section 2.5.8).



CAUTION – Avoid Invalidating Warranty

Servicing or handling of circuit components requires electrostatic discharge protection, i.e. ESD grounding straps, mats and containers. Failure to use ESD protection when working with electronic assemblies will void the instrument warranty. For information on preventing ESD damage, refer to the manual, Fundamentals of ESD, PN 04786, which can be downloaded from our website at <http://www.teledyne-api.com> under Help Center > Product Manuals in the Special Manuals section..

J19, J21, J23 Analog Output Setup:

- For **voltage** output of any one, two, or all:
 1. Jumper two leftmost pins.
 2. Jumper next two leftmost pins.
 3. Calibrate per Analog I/O Configuration menu.
- For **current** output of any one, two, or all:
 1. Remove jumper shunts.
 2. Install Current Loop option.
 3. Calibrate per Analog I/O Configuration menu.

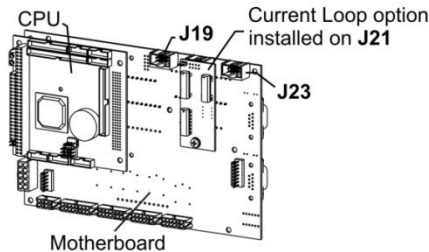
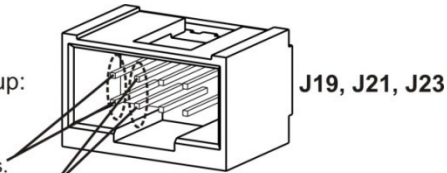

Example setup: install jumper shunts for voltage output on J19 and J23; remove jumper shunts and install Current Loop option for current output on J21.

Figure 2-7. Current Loop Option Installed on the Motherboard



T100, T100U, T100H

CONVERTING CURRENT LOOP ANALOG OUTPUTS TO STANDARD VOLTAGE OUTPUTS

To convert an output configured for current loop operation to the standard 0 to 5 VDC output operation:

1. Turn off power to the analyzer.
2. If a recording device is connected to the output being modified, disconnect it.
3. Remove the top cover.
 - Remove the set screw located in the top, center of the rear panel.
 - Remove the screws fastening the top cover to the unit (one per side).
 - Slide the cover back and lift the cover straight up.
4. Remove the screw holding the current loop option to the motherboard.
5. Disconnect the current loop option PCA from the appropriate connector on the motherboard (see Figure 2-7).
6. Each connector, J19 and J23, requires two shunts. Place one shunt on the two left most pins and the second shunt on the two adjacent pins (see Figure 2-7).
7. Return the top cover to the analyzer and secure.

The analyzer can now have a voltage-sensing recording device attached to that output.

2.3.1.4. CONNECTING THE STATUS OUTPUTS (DIGITAL OUTPUTS)

The 12-pin STATUS connector allows the digital status outputs to report analyzer conditions (configured through the Setup>Digital Outputs menu) via optically isolated NPN transistors that sink up to 50 mA of DC current. These outputs can be used to interface with devices that accept logic-level digital inputs, such as Programmable Logic Controllers (PLCs). Each status bit is an open collector output that can withstand up to 40 VDC. All of the emitters of these transistors are tied together and available at pin D (see Figure 2-8).

ATTENTION

COULD DAMAGE INSTRUMENT AND VOID WARRANTY

Most PLC's have internal provisions for limiting the current that the input will draw from an external device. When connecting to a unit that does not have this feature, an external dropping resistor must be used to limit the current through the transistor output to less than 50 mA. At 50 mA, the transistor will drop approximately 1.2V from its collector to emitter.

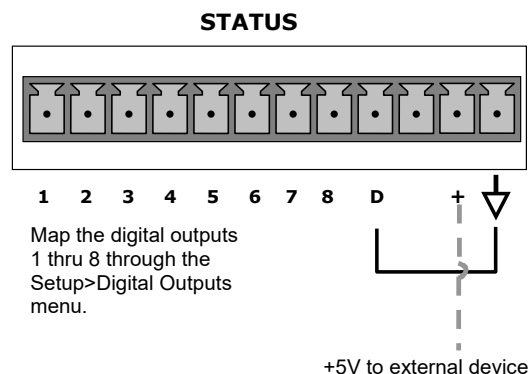

Figure 2-8. Status Output Connector for Digital Outputs



T100, T100U, T100H

Table 2-4. Status Output Pin Assignments

PIN	STATUS DEFINITION	CONDITION
1-8	Configurable through the Setup>Digital Outputs menu	Collector side of individual status output opto-isolators.
D	Emitter BUS	The emitters of the transistors on pins 1 to 8 are bussed together.
Blank	NO CONNECTION	
+	DC Power	+ 5 VDC, 300 mA source maximum
↓	Digital Ground	The ground level from the analyzer's internal DC power supplies. This connection should be used as the ground return when +5VDC power is used.

2.3.1.5. CONNECTING THE CONTROL INPUTS (DIGITAL INPUTS)

With zero and span valves option installed, two digital control inputs in the rear panel CONTROL IN connector, can be used to remotely activate the zero and span calibration modes (see Section 4.5.2.1).

Energize the Control Inputs either by the internal +5V available from the pin labeled “+” (more convenient), or by a separate external 5 VDC power supply (ensures that these inputs are truly isolated). Refer to Figure 2-9.

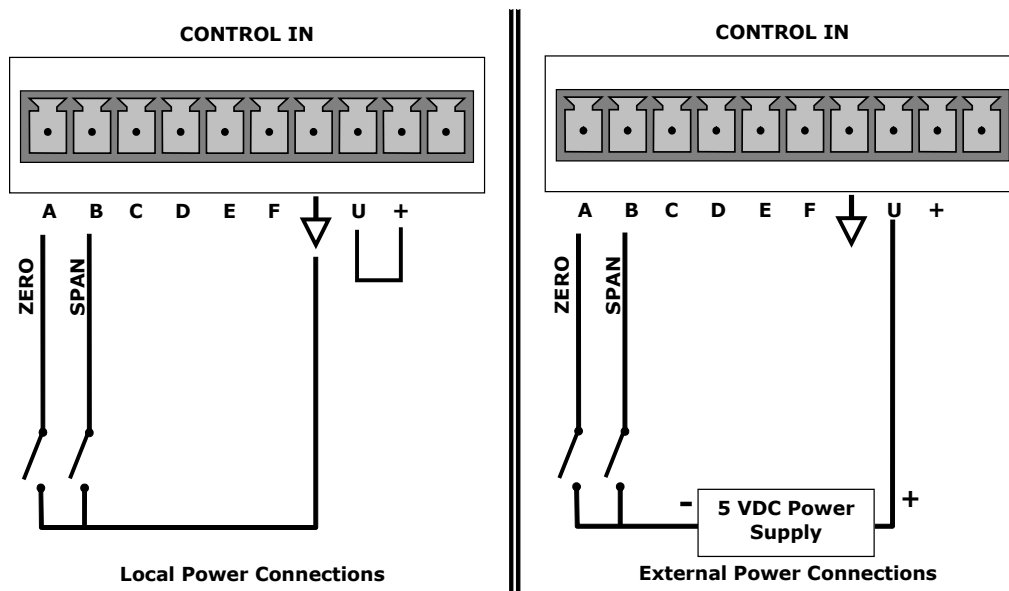



Figure 2-9. Energizing the Control Inputs



T100, T100U, T100H

Table 2-5. Control Input Pin Assignments

INPUT #	STATUS DEFINITION	ON CONDITION
A	Remote Zero Cal	The analyzer is placed in Zero Calibration mode.
B	Remote Span Cal	The analyzer is placed in Span Calibration mode.
C, D, E & F	Spare	
	Digital Ground	The ground level from the analyzer's internal DC Power Supplies (same as chassis ground).
U	External Power input	Input pin for +5 VDC is required to activate pins A – F.
+	5 VDC output	Internally generated 5V DC power. To activate inputs A – F, place a jumper between this pin and the “U” pin. The maximum amperage through this port is 300 mA (combined with the analog output supply, if used).

2.3.1.6. CONCENTRATION ALARM RELAY (OPTION 61)

The concentration relay option provides four (4) “dry contact” relays on the rear panel (Figure 2-10), each with 3 pins: Common (C), Normally Open (NO), and Normally Closed (NC). The Relays can be mapped to reflect various internal instrument conditions and states. Configure these outputs through the Setup>Digital Outputs menu (Section 2.5.7) under MB Relay [1 thru 4].

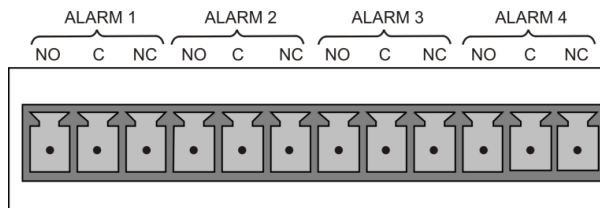

Figure 2-10. Concentration Alarm Relay

2.3.1.7. CONNECTING COMMUNICATIONS INTERFACES

ETHERNET CONNECTION

For network or Internet communication with the analyzer, connect an Ethernet cable from the analyzer’s rear panel Ethernet interface connector to an Ethernet port. Although the analyzer is shipped with DHCP enabled by default, it should be manually configured with a static IP address.

Configuration: Section 2.5.10.5



T100, T100U, T100H

USB (OPTION) CONNECTION

The rear panel USB option is for direct communication between the analyzer and a PC. Connect a USB cable between the analyzer and a computer USB port. Computer and instrument baud rates must match.

Note If this option is installed, the rear panel RS232 (COM2) port cannot be used for anything other than RS-232 Multidrop communication.

RS-232 CONNECTION

For RS-232 communications with data terminal equipment (DTE) or with data communication equipment (DCE) connect either a DB9-female-to-DB9-female cable (Teledyne API part number WR000077) or a DB9-female-to-DB25-male cable (Option 60A), as applicable, from the analyzer's RS-232 port (see Figure 2-11 for connector pin assignments) to the device. Adjust the rear panel DCE-DTE switch to select DTE or DCE as appropriate (Section 3.4).

Configuration: Section 3.5.1 and Section 3.7.2 (for Hessen protocol)

Important

IMPACT ON READINGS OR DATA

Cables that appear to be compatible because of matching connectors may incorporate internal wiring that makes the link inoperable. Check cables acquired from sources other than Teledyne API for pin assignments (Figure 2-11) before using.

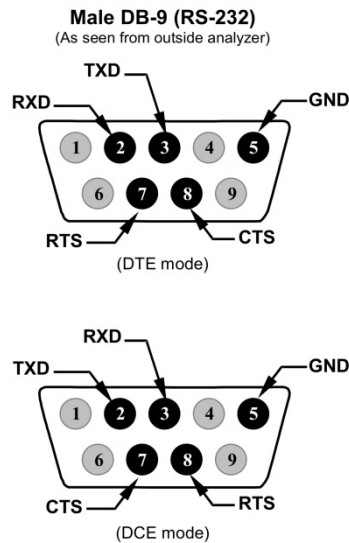

Figure 2-11. Rear Panel Connector Pin-Outs for RS-232 Mode

The signals from these two connectors are routed from the motherboard via a wiring harness to two 10-pin connectors on the CPU card, J11 and J12 (Figure 2-12).



T100, T100U, T100H

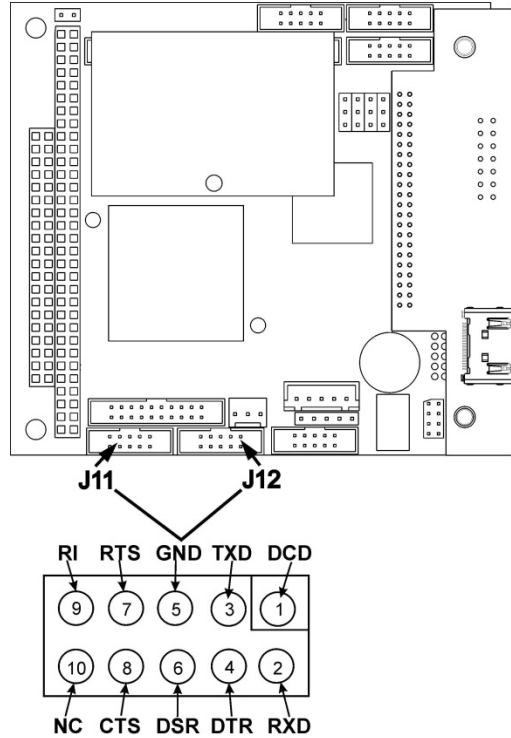

Figure 2-12. Default Pin Assignments for CPU COM Port Connector (RS-232)

Teledyne API offers two mating cables, one of which should be applicable for your use.

- P/N WR000077, a DB-9 female to DB-9 female cable, 6 feet long. Allows connection of the serial ports of most personal computers.
- P/N WR000024, a DB-9 female to DB-25 male cable. Allows connection to the most common styles of modems (e.g. Hayes-compatible) and code activated switches.

Both cables are configured with straight-through wiring and should require no additional adapters.

Note

Cables that appear to be compatible because of matching connectors may incorporate internal wiring that makes the link inoperable. Check cables acquired from sources other than Teledyne API for pin assignments before using.

To assist in properly connecting the serial ports to either a computer or a modem, there are activity indicators just above the RS-232 port. Once a cable is connected between the analyzer and a computer or modem, both the red and green LEDs should be on.

- If the lights are not lit, locate the small switch on the rear panel to switch it between DTE and DCE modes.
- If both LEDs are still not illuminated, ensure that the cable properly constructed.



T100, T100U, T100H

Received from the factory, the analyzer is set up to emulate an RS-232 DCE device. (View these parameters in the Setup>Comm>COM1[COM2] menu).

RS-232 (COM1): RS-232 (fixed) DB-9 male connector

- **Baud rate:** 115200 bits per second (baud)
- **Data Bits:** 8 data bits with 1 stop bit
- **Parity:** None

COM2: RS-232 (configurable to RS 485), DB-9 female connector

- **Baud rate:** 19200 bits per second (baud)
- **Data Bits:** 8 data bits with 1 stop bit
- **Parity:** None

RS-232 MULTIDROP (OPTION 62) CONNECTION

When the RS-232 Multidrop option is installed, connection adjustments and configuration through the menu system are required. This section provides instructions for the internal connection adjustments, then for external connections, and ends with instructions for menu-driven configuration.

Note

Because the RS-232 Multidrop option uses both the RS232 and COM2 DB9 connectors on the analyzer's rear panel to connect the chain of instruments, COM2 port is no longer available for separate RS-232 or RS-485 operation.

ATTENTION

COULD DAMAGE INSTRUMENT AND VOID WARRANTY
Printed Circuit Assemblies (PCAs) are sensitive to electro-static discharges too small to be felt by the human nervous system. Failure to use ESD protection when working with electronic assemblies will void the instrument warranty. For information on preventing ESD damage, refer to the manual, Fundamentals of ESD, PN 04786, which can be downloaded from our website at <http://www.teledyne-api.com> under Help Center > Product Manuals in the Special Manuals section.

In each instrument with the Multidrop option there is a shunt jumpering two pins on the serial Multidrop and LVDS printed circuit assembly (PCA), as shown in Figure 2-13. This shunt must be removed from all instruments except that designated as last in the multidrop chain, which must remain terminated. This requires powering off and opening each instrument and making the following adjustments:

1. With **NO power** to the instrument, remove its top cover and lay the rear panel open for access to the Multidrop/LVDS PCA, which is seated on the CPU.
2. On the Multidrop/LVDS PCA's JP2 connector, remove the shunt that jumpers Pins 21 ↔ 22 as indicated in. (Do this for all but the last instrument in the chain where the shunt should remain at Pins 21 ↔ 22).



T100, T100U, T100H

3. Check that the following cable connections are made in *all* instruments (again refer to Figure 2-13):
 - J3 on the Multidrop/LVDS PCA to the CPU's COM1 connector
(Be aware that the CPU's COM2 connector is not used in Multidrop)
 - J4 on the Multidrop/LVDS PCA to J12 on the motherboard
 - J1 on the Multidrop/LVDS PCA to the front panel LCD

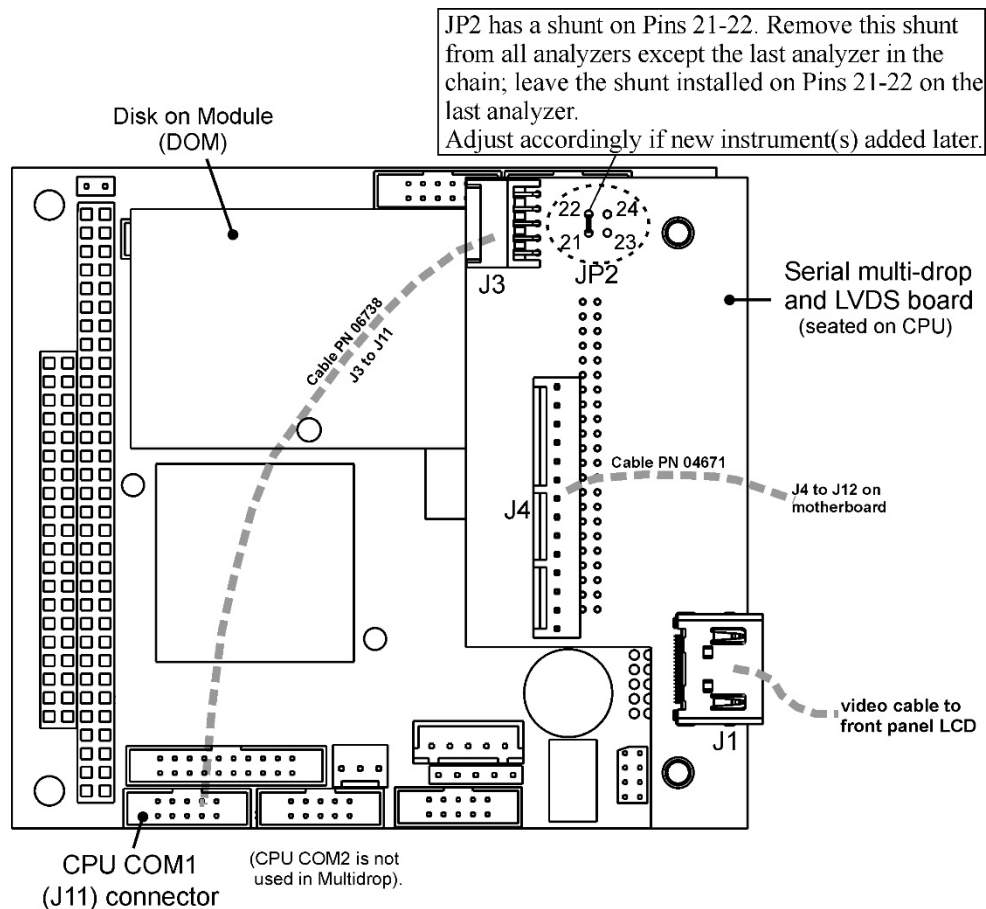

Figure 2-13. Jumper and Cables for Multidrop Mode

Note

If you are adding an instrument to the end of a previously configured chain, remove the shunt between Pins 21 □ 22 of JP2 on the Multidrop/LVDS PCA in the instrument that was previously the last instrument in the chain.

4. Close the instrument.
5. Referring to Figure 2-14 use straight-through DB9 male → DB9 female cables to interconnect the host RS232 port to the first analyzer's RS232 port; then from the first analyzer's COM2 port to the second analyzer's RS232 port; from the second analyzer's COM2 port to the third analyzer's RS232 port, etc., connecting in this fashion up to eight analyzers, subject to the distance limitations of the RS-232 standard.



T100, T100U, T100H

6. On the rear panel of each analyzer, adjust the DCE DTE switch so that the green and the red LEDs (RX and TX) of the COM1 connector (labeled RS232) are both lit. (Ensure you are using the correct RS-232 cables internally wired specifically for RS-232 communication; see Figure 2-12).

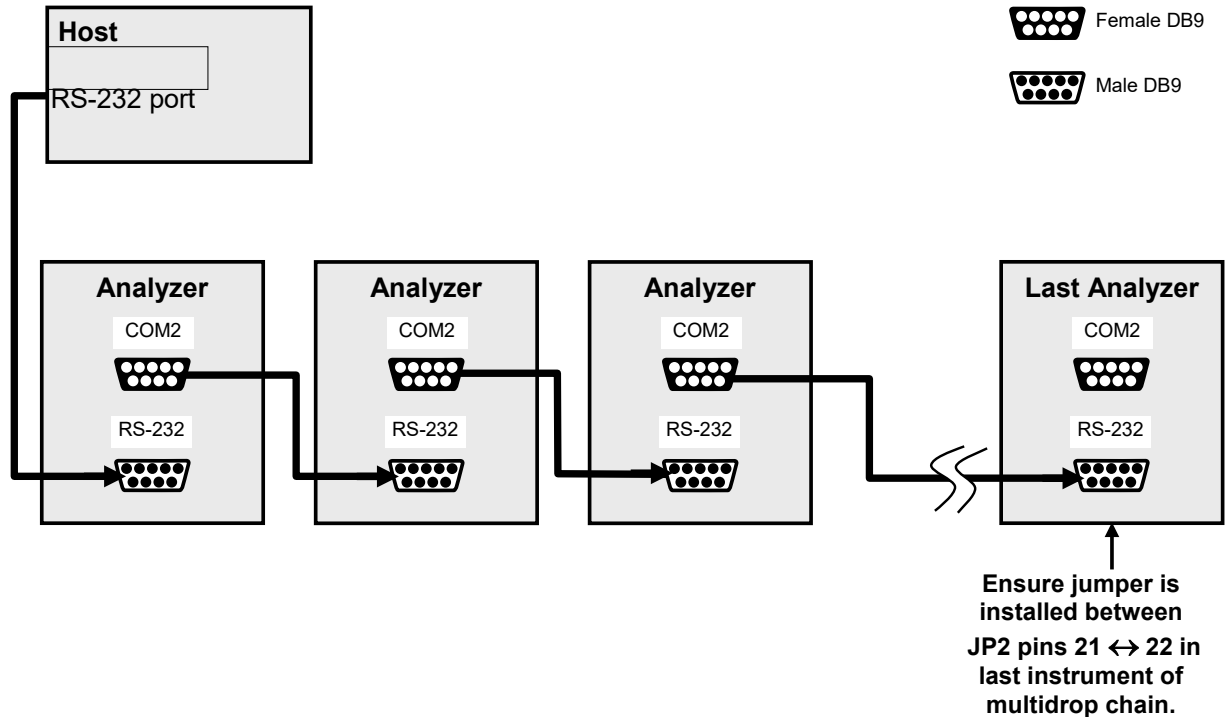

Figure 2-14. RS-232 Multidrop PCA Option Host/Analyzer Interconnect Diagram

7. BEFORE communicating from the host, power on the instruments and check that the user-selectable Instrument ID is unique for each: in the Setup>Vars menu, check Instrument ID in the list of variables. To change, highlight the variable and press the Edit button; once changed, press the Enter button.
8. Next, in the Setup>Comm>COM1 menu (do not use the COM2 menu for multidrop), use the Edit button to set COM1 Quiet Mode and COM1 Multidrop to ENABLED; then press the Accept button.
9. Also check the COM1 Baud Rate to ensure it reads the same for all instruments (edit if needed and press the Accept button).

Note

The (communication) Host instrument can address only one instrument at a time, each by its unique ID (see step 7 above).

Note

Teledyne API recommends setting up the first link, between the Host and the first analyzer, and testing it before setting up the rest of the chain.



T100, T100U, T100H

2.3.1.8. CONNECTING THE EXTERNAL PUMP (T100H)

The T100H is equipped with an external pneumatic pump. This pump is powered separately from the instrument via its own power cord. The pump has no ON/OFF switch and should begin operating as soon as it is plugged into a live power supply.

2.3.2. PNEUMATIC CONNECTIONS

This section provides pneumatic connection and setup instructions for basic and optional configurations. Pneumatic flow diagrams are shown in Section 2.3.3. Calibration instructions are provided in Section 4.

Before making the pneumatic connections, carefully note the following cautionary and special messages:

CAUTION – General Safety Hazard

Sulfur Dioxide (SO₂) is a toxic gas. Obtain a Safety Data Sheet (SDS) for this material, and rigorously follow the safety guidelines described there.



Vent the exhaust from the analyzer's internal pump to outside the immediate area or shelter surrounding the instrument.

Do not vent calibration gas or sample gas into enclosed areas.

Sample and calibration gases should only come into contact with PTFE (Teflon) or glass tubes and fixtures.

Do not allow sample and calibration gases to come into contact with brass or stainless steel fittings prior to the reaction cell.

CAUTION – General Safety Hazard

In units with a permeation tube option installed, vacuum pump must be connected and powered on to maintain constant gas flow through the analyzer at all times. Insufficient gas flow allows gas to build up to levels that will contaminate the instrument or present a safety hazard to personnel.



Remove the permeation tube when taking the analyzer out of operation and store in sealed container (use the original shipping packaging).

(See Section 5.6.2 for instructions on how to remove the permeation tube when the unit is not in operation).



ATTENTION

COULD DAMAGE INSTRUMENT AND VOID WARRANTY

Vent Pressurized Gas:

When any gas (span, zero air, sample) is received from a pressurized manifold, always provide a vent to equalize the pressure with the ambient atmosphere before it enters the instrument to ensure that the gases input do not exceed the instrument's maximum inlet pressure, as well as to prevent back diffusion and pressure effects

Remove Dust Plugs:

Remove dust plugs from rear panel exhaust and supply line fittings before powering on the instrument.

Keep dust plugs for reuse in future storage or shipping to prevent debris from entering the pneumatics.

Important

IMPACT ON READINGS OR DATA

Sample and calibration gases should only come into contact with PTFE tubing.

Run a leak check once the appropriate pneumatic connections have been made; check all pneumatic fittings for leaks per Section 5.4.12.1 (or Section 5.4.12.2 for detailed check if any leaking is suspected).

2.3.2.1. CRITICAL TUBING, PRESSURE, VENTING AND EXHAUST REQUIREMENTS

The requirements presented in this section apply to all pneumatic connection instructions. All other connection instructions are provided with their respective instrument configurations in Sections 2.3.2.2 through 2.3.2.5.

Tubing:

- PTFE material
- Outer diameter (OD) minimum ¼" .
- Min/max length 2 meters to 10 meters.

Pressure:

- All Sample gas pressure must be at ambient atmospheric pressure, no greater than 1.0 psig.

Venting (to prevent back diffusion and pressure effects):

- Run tubing outside the enclosure or at least away from immediate area surrounding the instrument.

Exhaust Outlet:

- Run tubing outside the enclosure.



2.3.2.2. BASIC CONNECTIONS FROM CALIBRATOR

Figure 2-15 and Figure 2-16 illustrate pneumatic connections for two of the possible basic configurations, except that the T100H has tubing first running from the EXHAUST port to the inlet port of its external pump, and then additionally from the pump's outlet port to outside the immediate area (Figure 2-17).

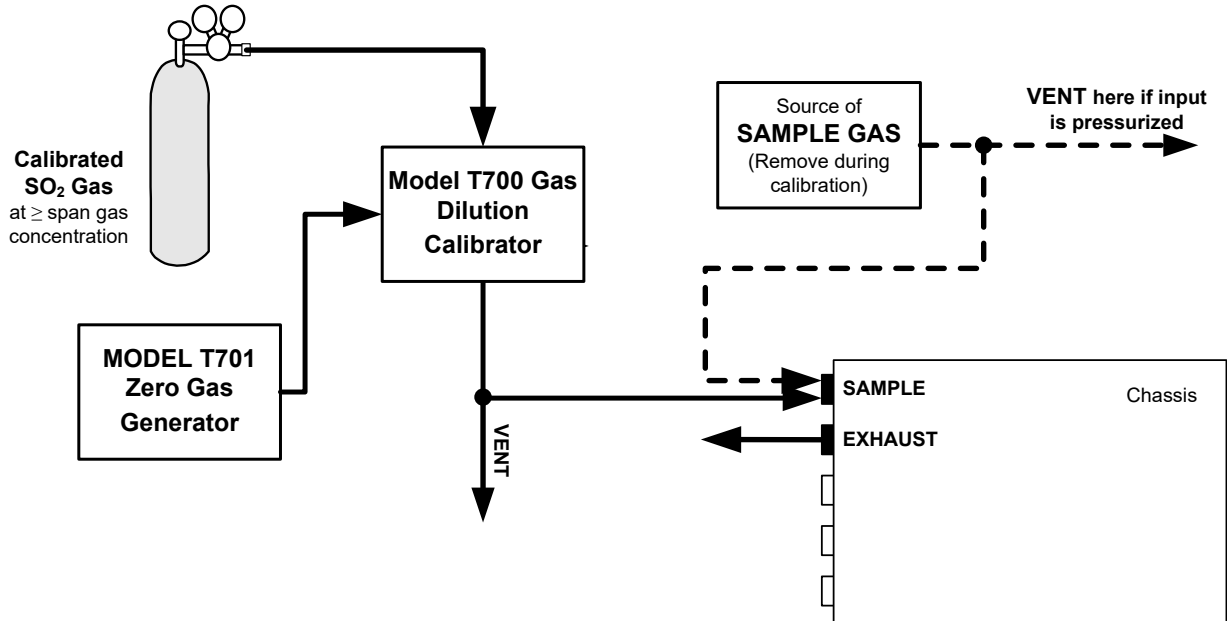

Figure 2-15. Gas Line Connections from Gas Dilution Calibrator – Basic Configuration

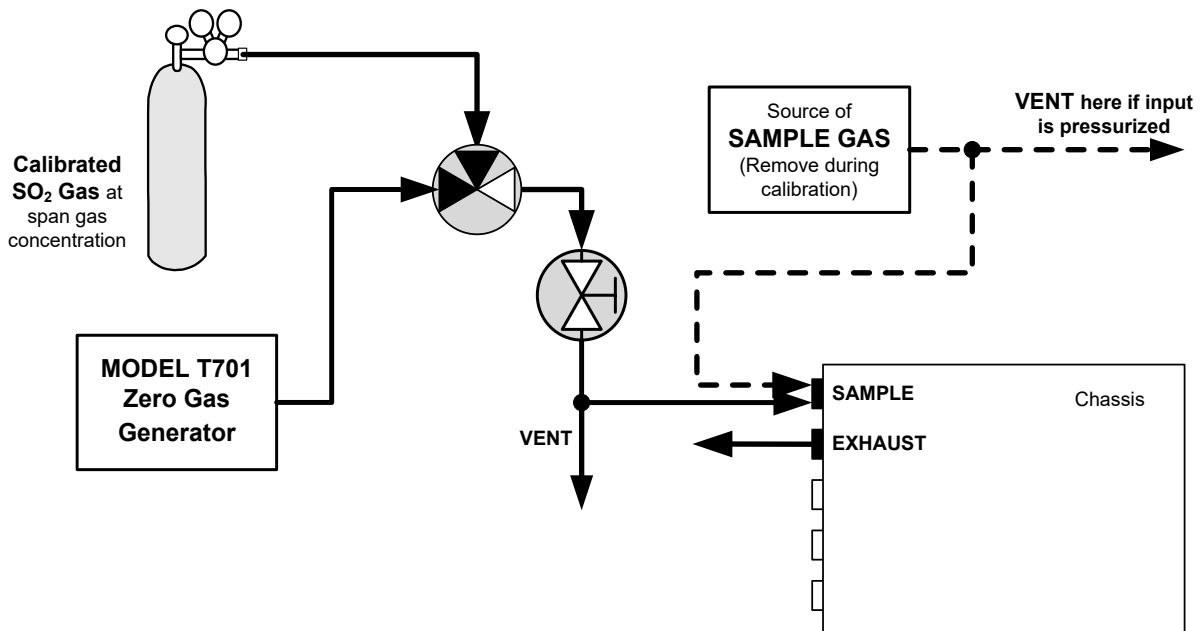

Figure 2-16. Gas Line Connections from Bottled Span Gas – Basic Configuration

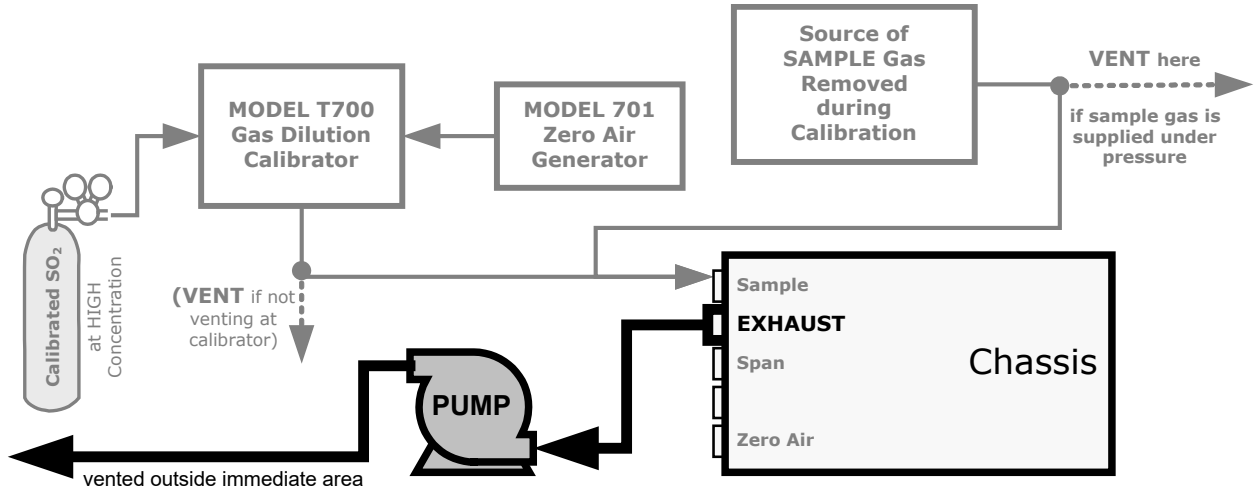

Figure 2-17. Example of T100H Pneumatic Connections

For the analyzer’s basic configuration, in addition to tubing, pressure, venting, and exhaust requirements set out in Section 2.3.2.1, make the following pneumatic connections:

SAMPLE INLET

Connect ¼” gas line not more than 2 m long, from sample gas source to this inlet.

When no zero/span/shutoff valve options, also connect line from calibration gas source to this inlet, but only when a calibration operation is actually being performed.

EXHAUST OUTLET

T100, T100U: Connect exhaust line made of PTFE tubing, minimum O.D ¼”, to this fitting. The exhaust line should be no longer than 10 meters, and should lead outside the shelter or immediate area surrounding the instrument.

T100H: Connect PTFE tubing, minimum O.D ¼”, from this fitting to the inlet port of the external pump, and connect same from outlet port of pump, no longer than 10 meters, leading outside the shelter or immediate area surrounding the instrument.

CALIBRATOR VENTING

Vent the output of the calibrator if calibrator not already vented.



2.3.2.3. CONNECTIONS WITH AMBIENT ZERO/SPAN (Z/S) VALVES (Opt 50A)

This valve package includes:

- two solenoid valves located inside the analyzer that allow the user to switch either zero, span or sample gas to the instrument's sensor
- two additional gas inlet ports (ZERO AIR and SPAN1)

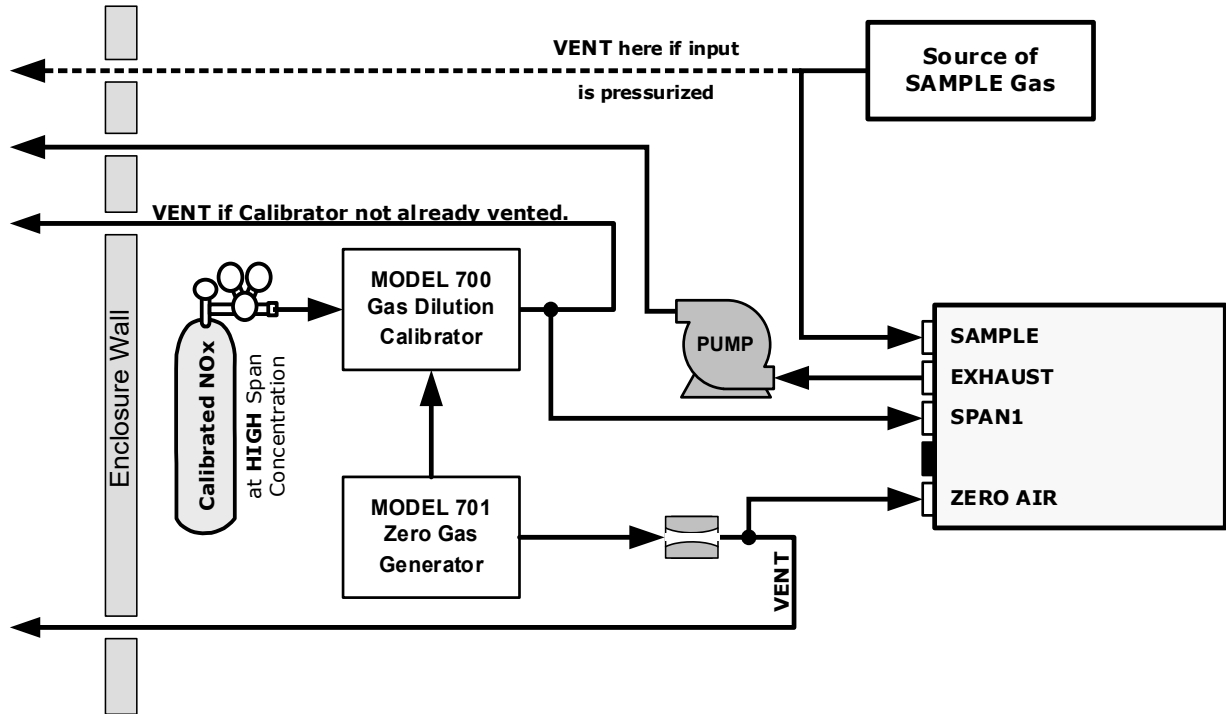

Figure 2-18. Gas Line Connections with Z/S Valves Option (OPT 50A)

In addition to tubing, pressure, venting, and exhaust requirements set out in Section 2.3.2.1, attach the following pneumatic lines:

SAMPLE GAS SOURCE

Attach a sample inlet line to the SAMPLE inlet fitting.

- In applications where the sample gas is received from a pressurized manifold, vent the sample gas line.

CALIBRATION GAS SOURCES

SPAN GAS Attach a gas line from the source of calibration gas (e.g. a Teledyne API's T700 Dynamic Dilution Calibrator) to the SPAN1 inlet.

ZERO AIR Zero air is supplied by the zero air generator such as a Teledyne API's M701. Attach a gas line from the source of zero air to the ZERO AIR inlet.

VENTING

Vent both the span gas and zero air supply lines.



2.3.2.4. T100, T100U CONNECTIONS W/AMBIENT ZERO/PRESSURIZED SPAN VALVES (Opt 50E)

This calibration valve package is appropriate for applications where span gas is being supplied from a pressurized source such as bottled NIST SRM gases. This option includes:

- a critical flow orifice and vent to maintain the span gas supply at 1 ATM
- a shutoff valve to preserve the span gas source when it is not in use
- two solenoid valves for the user to switch either zero, span or sample gas to the instrument's sensor
- three additional gas inlet ports (ZERO AIR, SPAN and VENT)

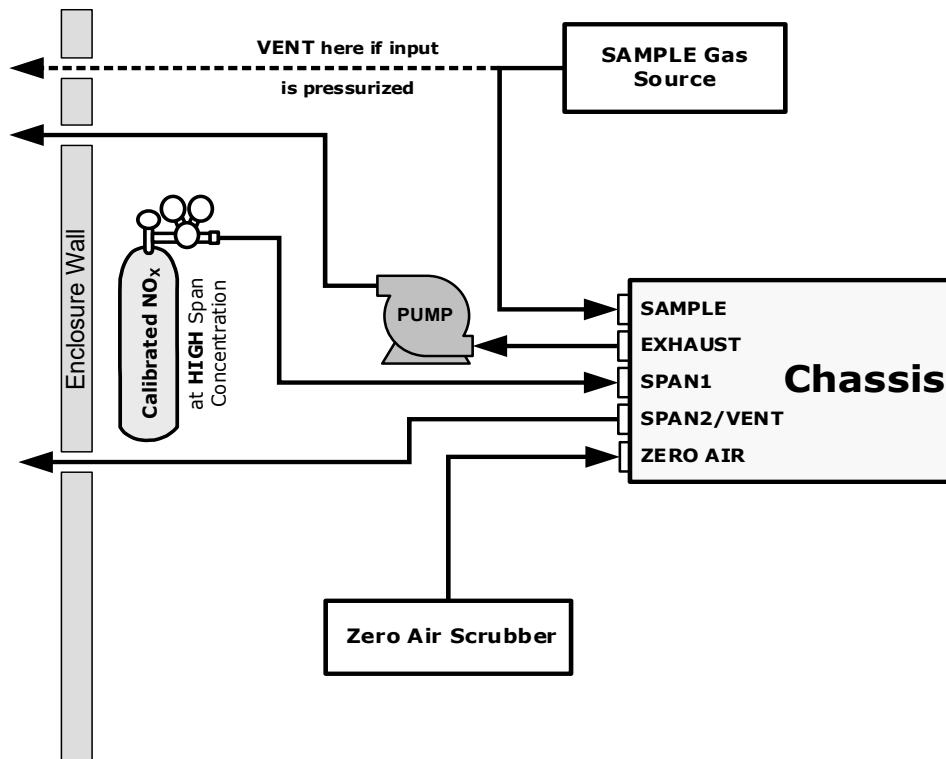

Figure 2-19. Gas Line Connection w/Ambient Zero/Pressurized Span Valves Option (OPT 50E)

In addition to tubing, pressure, venting, and exhaust requirements set out in Section 2.3.2.1, attach the following pneumatic lines:

SAMPLE GAS SOURCE

Attach a sample inlet line to the SAMPLE inlet fitting.

- In applications where the sample gas is received from a pressurized manifold, vent the sample gas line.

CALIBRATION GAS SOURCES

SPAN GAS Attach a gas line from the pressurized source of calibration gas (e.g. a bottle of NISTSRM gas) to the SPAN1 inlet. Use PTFE tubing, minimum O.D ¼”.

ZERO AIR (the dual-stage zero Air Scrubber makes zero air)



VENTING

Vent the SPAN2/VENT outlet.

2.3.2.5. T100, T100U CONNECTIONS W/ZERO SCRUBBER & INTERNAL ZERO SPAN (IZS) (Opt 50G)

The internal span gas generator and calibration valve option is intended for applications where there is a need for frequent automated calibration checks without access to an external source of span gas. (See the end of this subsection for important information about “Internal Span Gas Generation”).

This valve package includes:

- an external scrubber filled with activated charcoal that removes SO₂ in order to produce zero air
- a heated enclosure for a permeation tube (This option package DOES NOT contain an actual permeation tube. Contact Sales for assistance in specifying the correct permeation tube for each application).
- one additional gas inlet port (ZERO AIR)
- one additional gas outlet port (FROM DRYER)
- two internal valves for switching between the sample gas inlet and the output of the zero/span subsystem

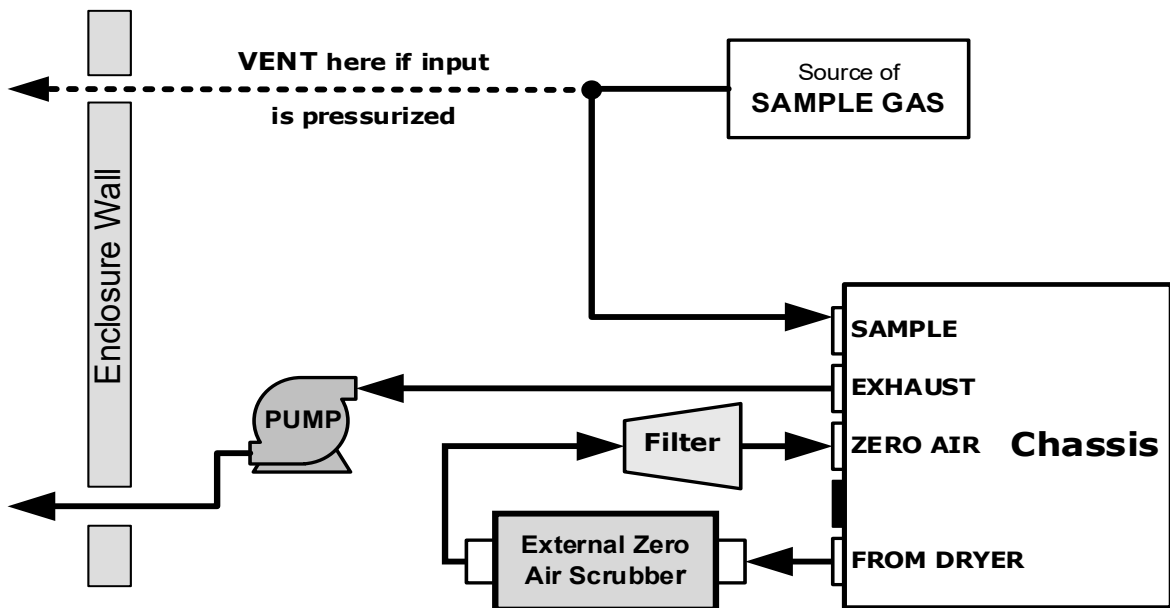

Figure 2-20. Gas Line Connection w/Zero Scrubber and IZS Option (OPT 50G)

The internal span gas generator utilizes an SO₂ permeation tube as a span gas source (see the “Internal Span Gas Generation” at the end of this section). The accuracy of these devices is only about $\pm 5\%$. Whereas this may be sufficient for frequent automated calibration checks (Figure 2-20), we recommend using certified gases for precise calibration (Figure 2-21).

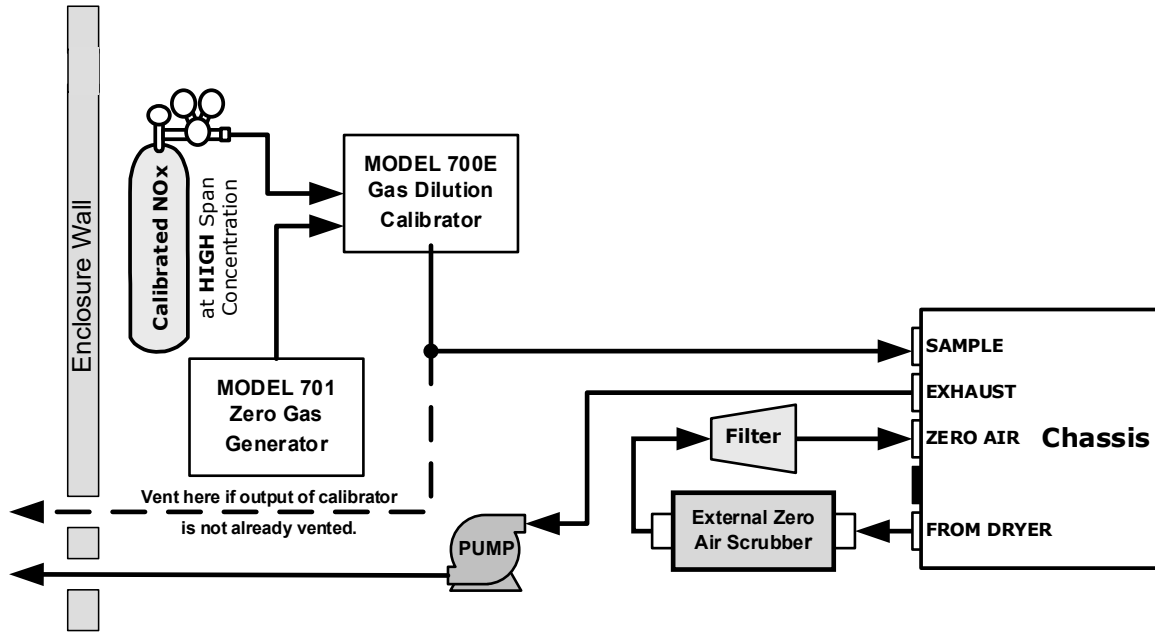

Figure 2-21. Pneumatic Connections for Precision Calibration when IZS Generator Present

In addition to tubing, pressure, venting, and exhaust requirements set out in Section 2.3.2.1, attach the following pneumatic lines:

SAMPLE GAS SOURCE

Connect a sample gas line to the SAMPLE inlet, and:

- In applications where the sample gas is received from a pressurized manifold and the analyzer is not equipped with one of the pressurized span options, a vent must be placed on the sample gas line.

CALIBRATION GAS SOURCES

- Internal: Uses the IZS generator.
- External (for precision calibration): CAL GAS & ZERO AIR SOURCES: The source of calibration gas is attached to the SAMPLE inlet.

VENTING

Vent the Sample line if input is pressurized.

INTERNAL SPAN GAS GENERATION

The primary component of the internal span option is a permeation tube containing liquid SO₂. As zero air is passed over a permeable membrane on the end of the tube, molecules of SO₂ slowly pass through the membrane mixing with the zero air. The speed at which the SO₂ permeates the membrane is called the effusion rate.



T100, T100U, T100H

The resulting concentration of the span gas is determined by three factors:

- size of the membrane (the larger the area of the membrane, the more permeation occurs)
- temperature of the SO₂ (increasing the temperature of the permeation tube increases the pressure inside the tube, thereby increasing the effusion).
- flow rate of the zero air (if the previous two variables are constant, the permeation rate of air into the zero air stream will be constant; therefore, a lower flow rate of zero air produces higher concentrations of SO₂).

The permeation tube enclosure is heated to a constant 50° C (10° above the maximum operating temperature of the instrument) in order to keep the permeation rate constant. The IZS heater is controlled by a precise PID (Proportional/Integral/Derivative) temperature control loop. A thermistor measures the actual temperature and reports it to the CPU for control feedback.

The flow rate of zero air across the permeation tube is maintained at 50 ± 10 cc/min by a critical flow orifice located in the analyzer's exhaust manifold.

Although the factors that influence the resulting span gas concentration can be kept at a constant, they also can be manipulated, thereby impacting the concentration.



2.3.3. PNEUMATIC FLOW DIAGRAMS

This section shows the basic pneumatic flow diagram followed by flow diagrams with options. Tables showing the valve operating states follow each of the flow diagrams with valve options.

2.3.3.1. PNEUMATIC FLOW FOR BASIC CONFIGURATION

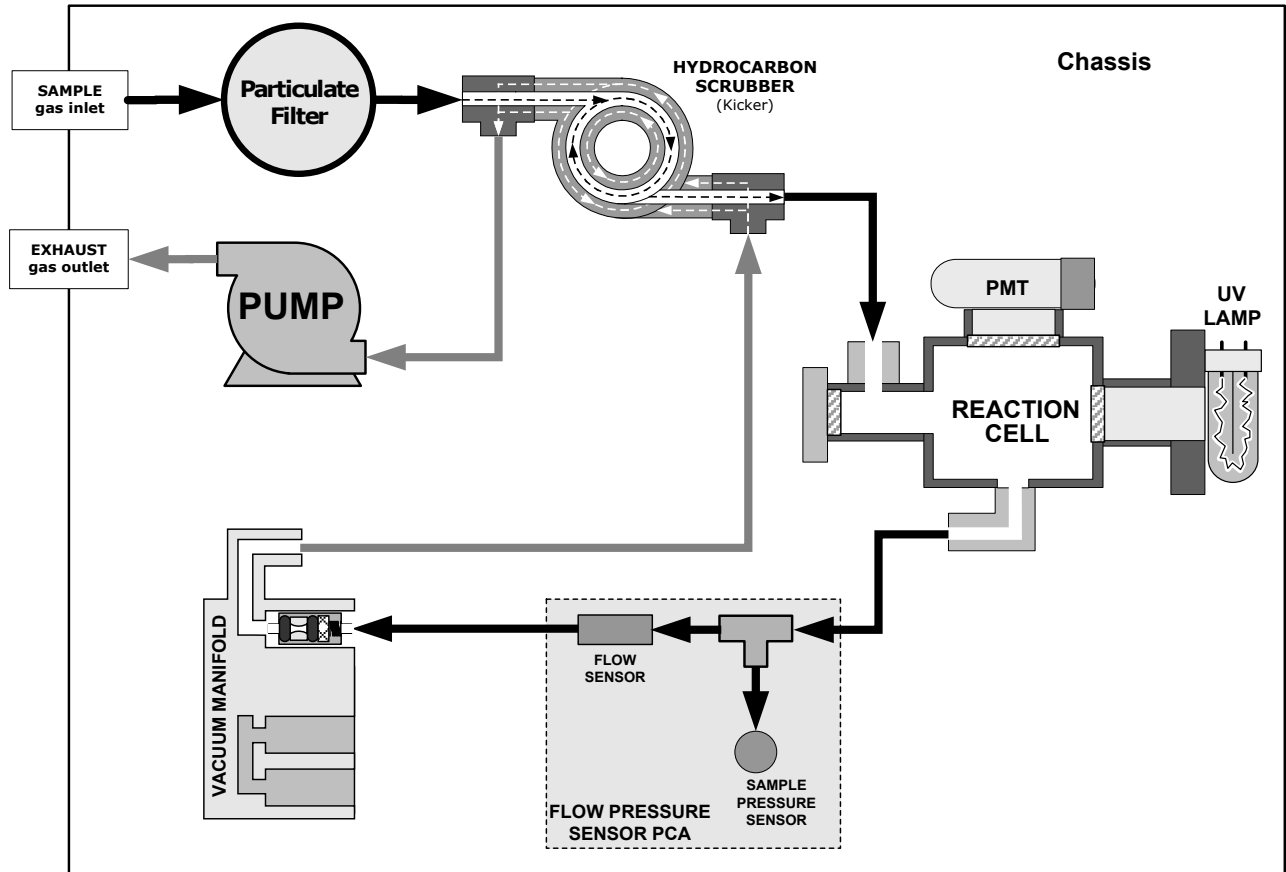

Figure 2-22. T100, T100U Pneumatics, Basic Configuration



T100, T100U, T100H

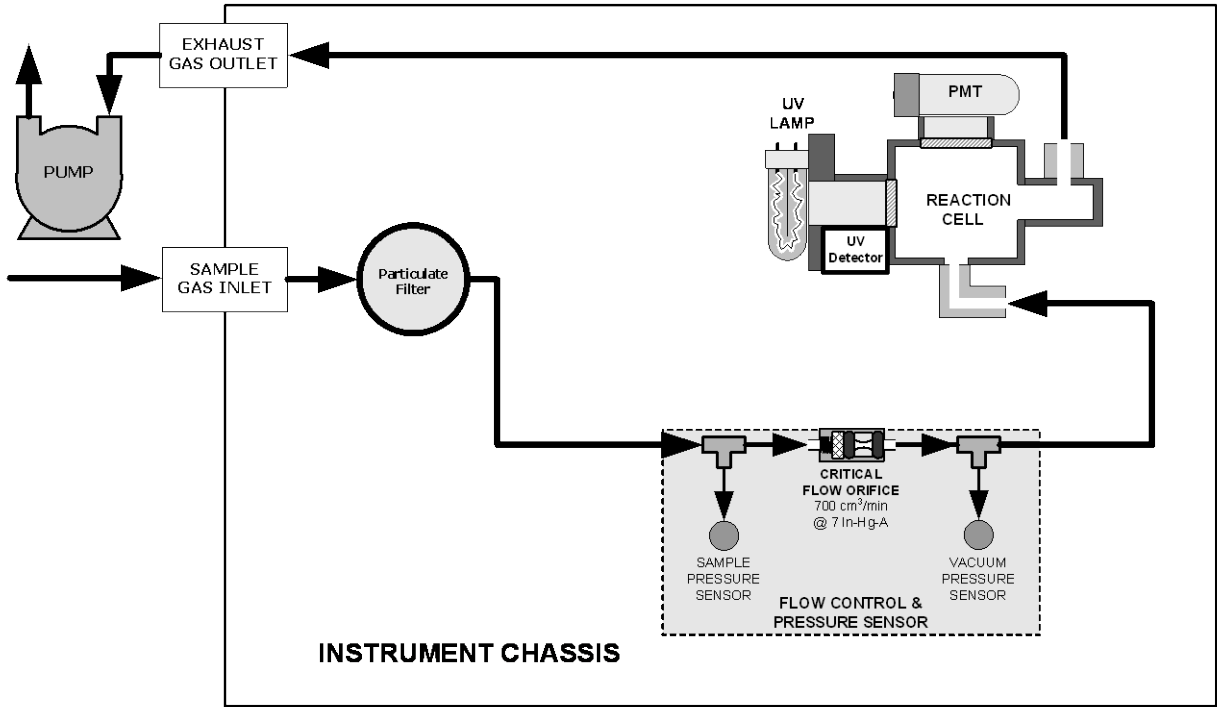

Figure 2-23. T100H Pneumatics, Basic Configuration

2.3.3.2. PNEUMATIC FLOW FOR ZERO/SPAN VALVES OPTION

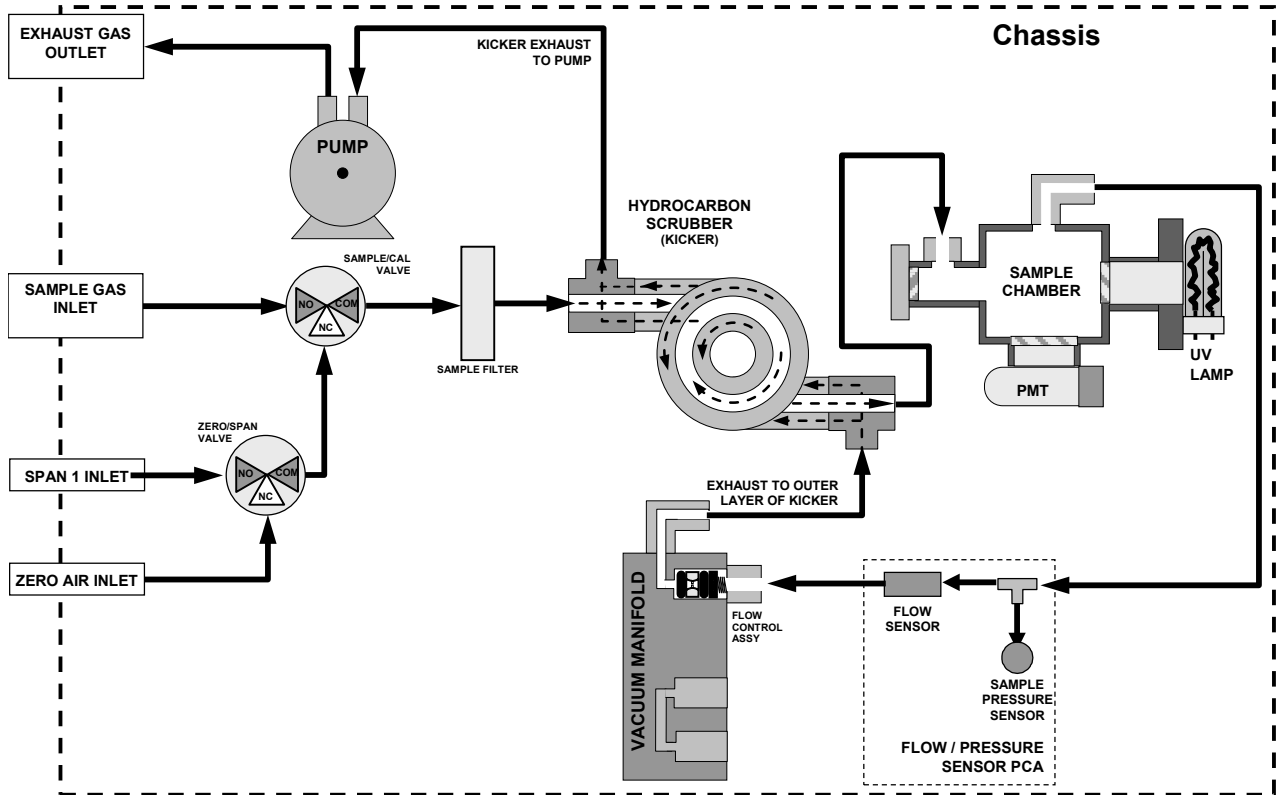

Figure 2-24. T100, T100U Pneumatics with Zero/Span Valves Option



T100, T100U, T100H

Table 2-6. Zero/Span and Sample/Cal Valve Operating States

MODE	VALVE	STATE	VALVE PORT STATUS
SAMPLE	Sample/Cal	Open to SAMPLE inlet	NO → COM
	Zero/Span	Open to ZERO AIR inlet	NO → COM
ZERO CAL	Sample/Cal	Open to ZERO/SPAN valve	NC → COM
	Zero/Span	Open to ZERO AIR inlet	NO → COM
SPAN CAL	Sample/Cal	Open to ZERO/SPAN valve	NC → COM
	Zero/Span	Open to SPAN GAS inlet	NC → COM

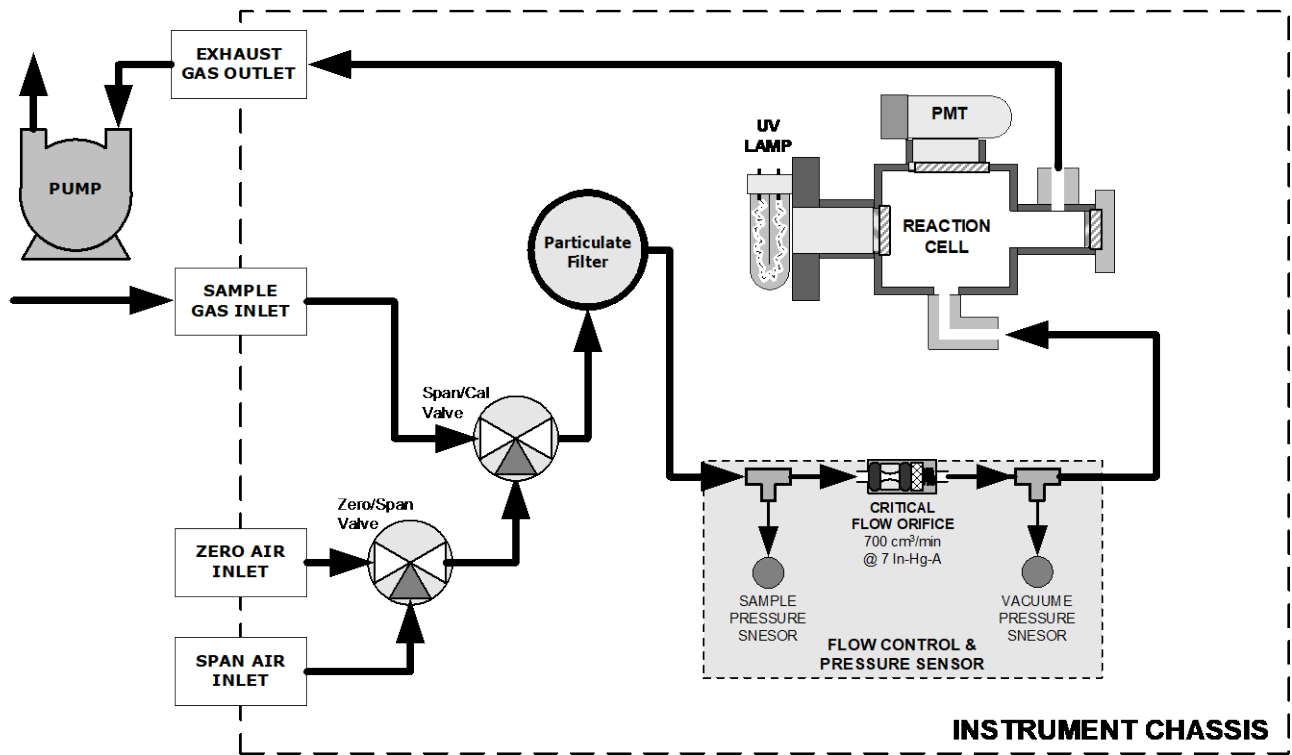

Figure 2-25. T100H Pneumatics with Zero/Span Valves Option



T100, T100U, T100H

2.3.3.3. PNEUMATIC FLOW FOR AMBIENT ZERO/PRESSURIZED SPAN OPTION

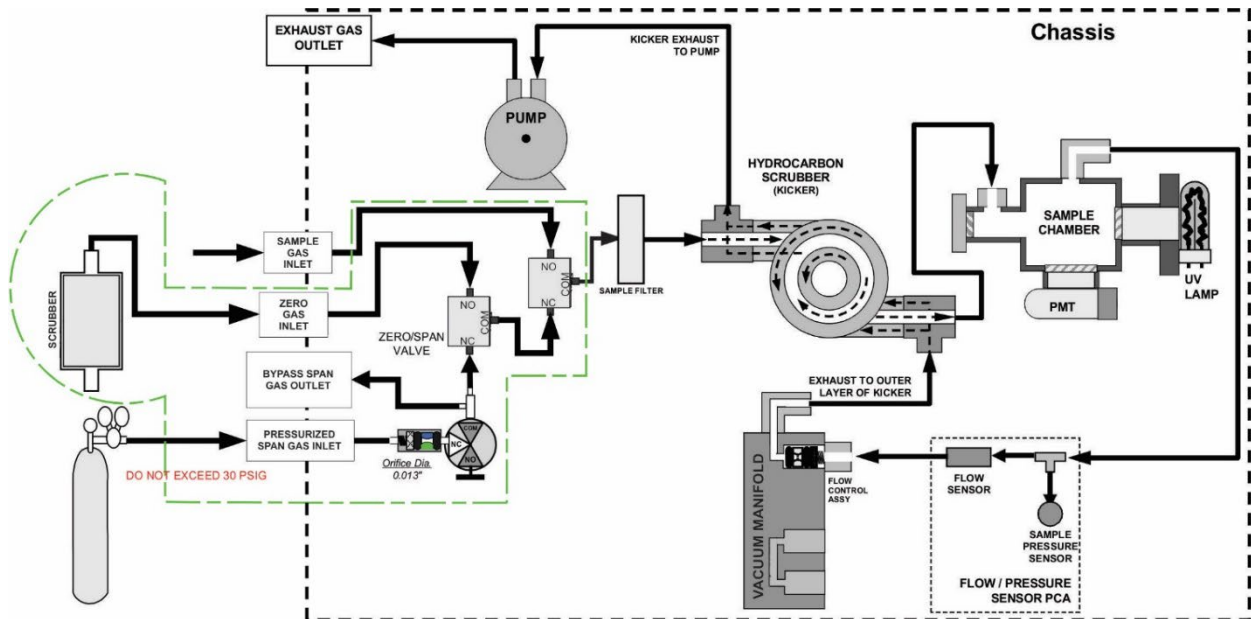

Figure 2-26. T100, T100U Pneumatics with Ambient Zero/Pressurized Span Valves Option

Table 2-7. Valve Operating States for Ambient Zero/Pressurized Span Option

MODE	VALVE	STATE	VALVE PORT STATUS
SAMPLE	Sample/Cal	Open to SAMPLE inlet	NO → COM
	Zero/Span	Open to ZERO AIR inlet	NO → COM
	Span Shutoff	Closed	
	Zero Air Shutoff	Closed	
ZERO CAL	Sample/Cal	Open to ZERO/SPAN valve	NC → COM
	Zero/Span	Open to ZERO AIR inlet	NO → COM
	Span Shutoff	OPEN	
	Zero Air Shutoff ¹	Closed	
SPAN CAL	Sample/Cal	Open to ZERO/SPAN valve	NC → COM
	Zero/Span	Open to SPAN inlet	NC → COM
	Span Shutoff	Closed	
	Zero Air Shutoff	OPEN	



2.3.3.4. PNEUMATIC FLOW FOR INTERNAL ZERO/SPAN (IZS) GAS GENERATOR OPTION

(Not available in the T100H)

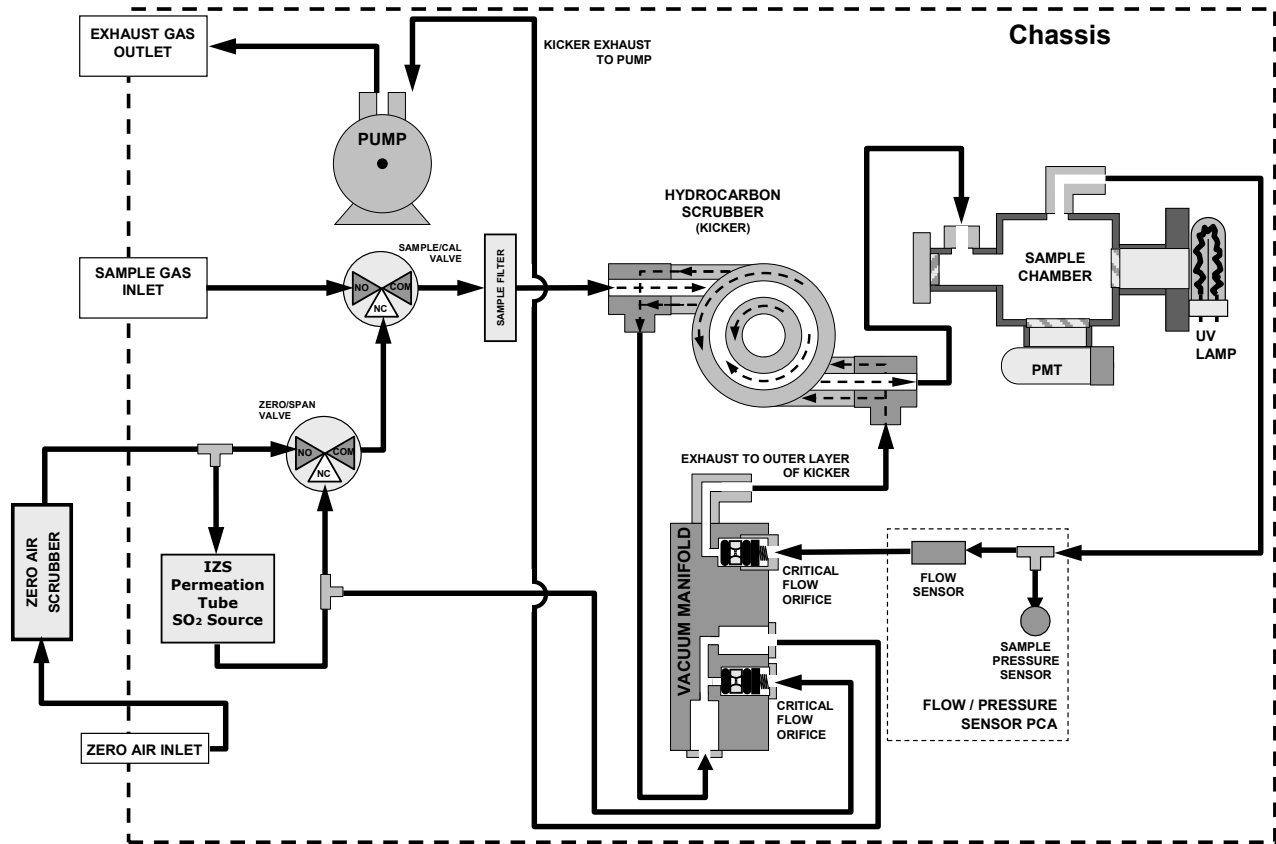

Figure 2-27. T100, T100U Pneumatics with IZS Option

Table 2-8. IZS Valve Option Operating States

MODE	VALVE	STATE	VALVE PORT STATUS
SAMPLE	Sample/Cal	Open to SAMPLE inlet	NO → COM
	Zero/Span	Open to ZERO AIR inlet	NO → COM
ZERO CAL	Sample/Cal	Open to ZERO/SPAN valve	NC → COM
	Zero/Span	Open to ZERO AIR inlet	NO → COM
SPAN CAL	Sample/Cal	Open to ZERO/SPAN valve	NC → COM
	Zero/Span	Open to SPAN GAS inlet	NC → COM

Note

The permeation tube is not included in the IZS Option and must be ordered separately.



2.3.3.5. PNEUMATIC FLOW WITH O₂ SENSOR OPTION

Figure 2-28 shows the internal, pneumatic connections for the analyzer with the oxygen (O₂) sensor option installed. (The pump will be external to the Exhaust outlet for the T100H). Pneumatically, the O₂ sensor draws a flow of 80 cm³/min in addition to the normal sample flow rate. It is separately controlled with its own critical flow orifice.

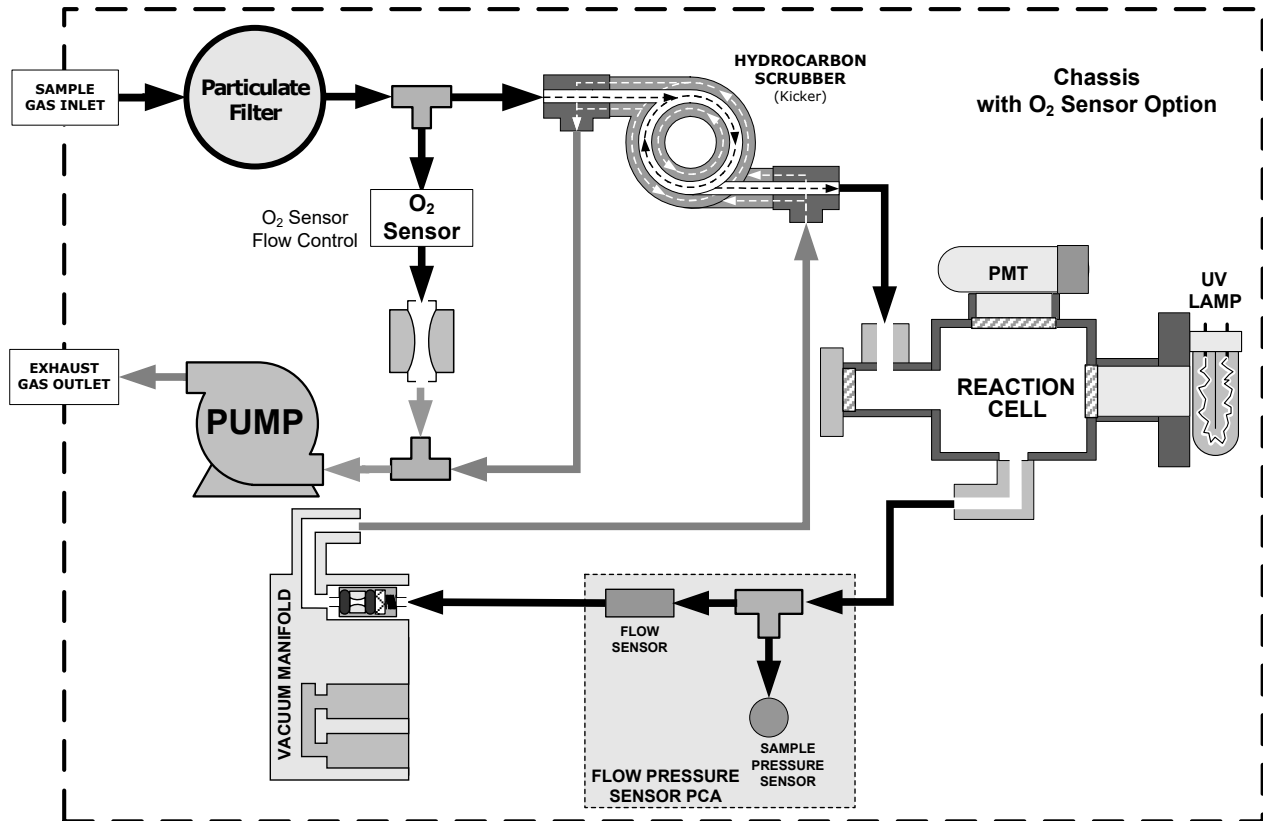

Figure 2-28. Pneumatics with O₂ Sensor

2.3.3.6. T100H PNEUMATIC FLOW WITH HYDROCARBON KICKER OPTION

Since hydrocarbons are not in the sample stream of the typical T100H application, the hydrocarbon scrubber is not included in the basic configuration. For applications that include hydrocarbons, the scrubber is offered as Option 86D (Figure 2-29). Figure 2-30 shows the pneumatic flow for the T100H with the hydrocarbon scrubber option.



T100, T100U, T100H

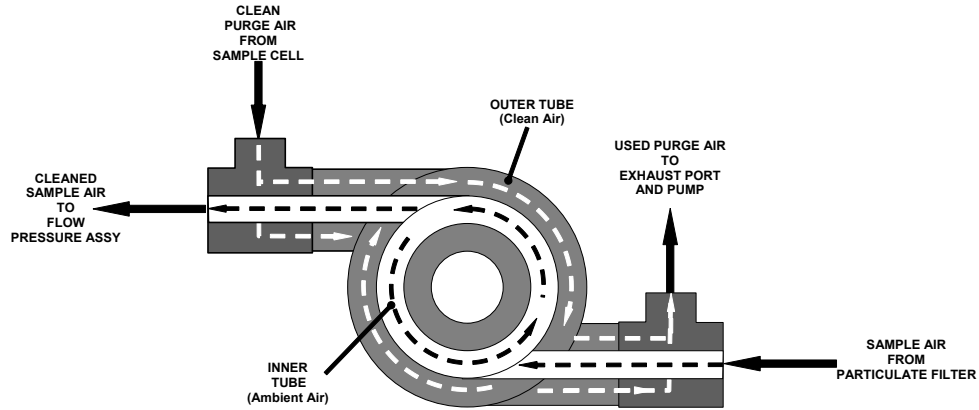

Figure 2-29. Hydrocarbon Scrubber (Kicker) – T100H Option 86D

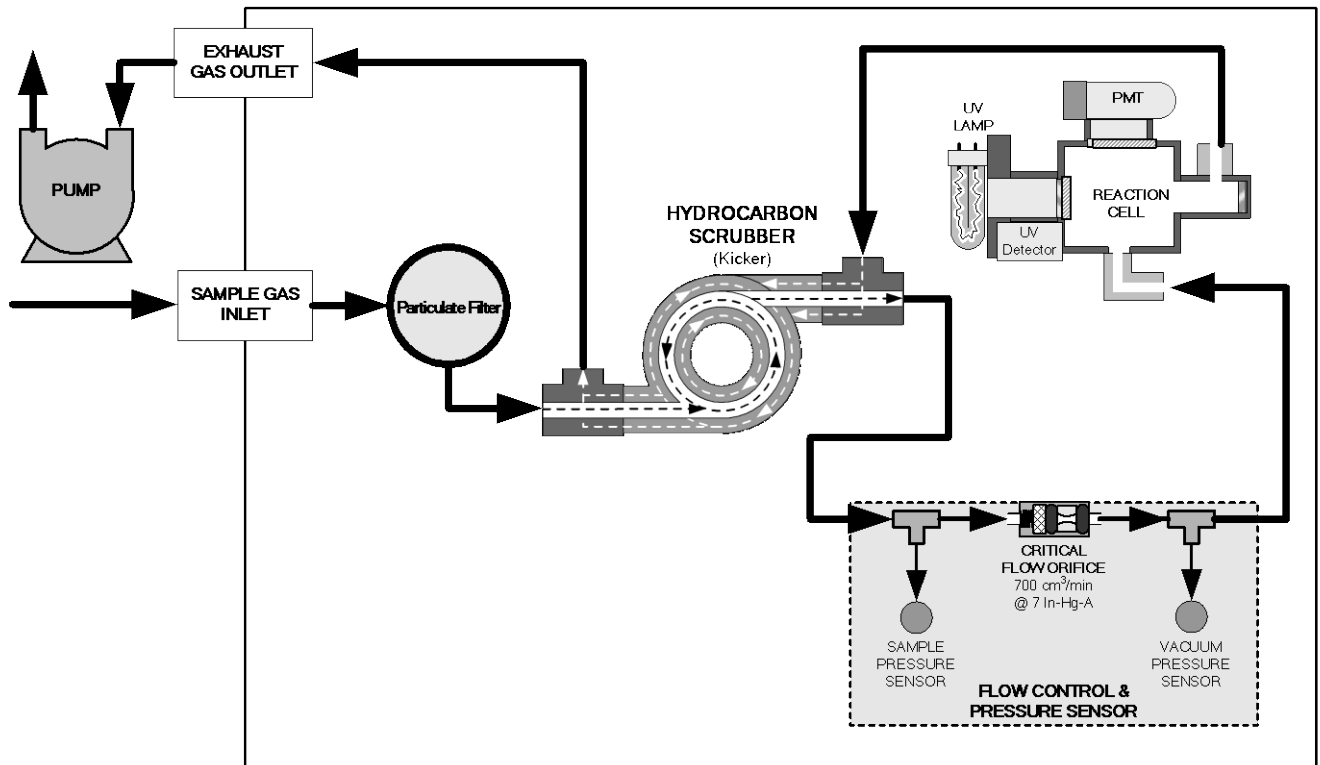

Figure 2-30. 2T100H Pneumatic Flow with Hydrocarbon Kicker Option 86D

2.3.4. STARTUP, FUNCTIONAL CHECKS AND CALIBRATION

We recommend reading Section 6 to become familiar with the principles of operation.

When the instrument is first started (Section 2.3.4.1), check its functionality (Section 2.3.4.3) and run an initial calibration (Section 2.3.4.4). Section 2.4 introduces the menu system, and Section 2.5 provides setup/customization instructions.



T100, T100U, T100H

2.3.4.1 STARTUP

Upon initial startup, a sequence of status screens (Figure 2-31) appear prior to the Home page (Figure 2-32).

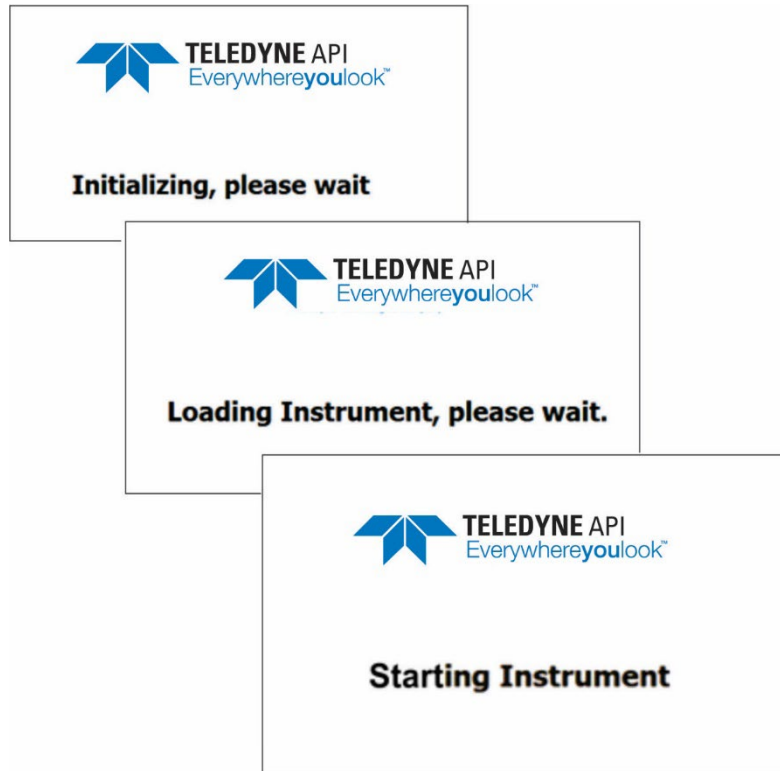

Figure 2-31. Status Screens at Startup

Upon any startup, this instrument should warm up for approximately one hour before reliable measurements can be taken.

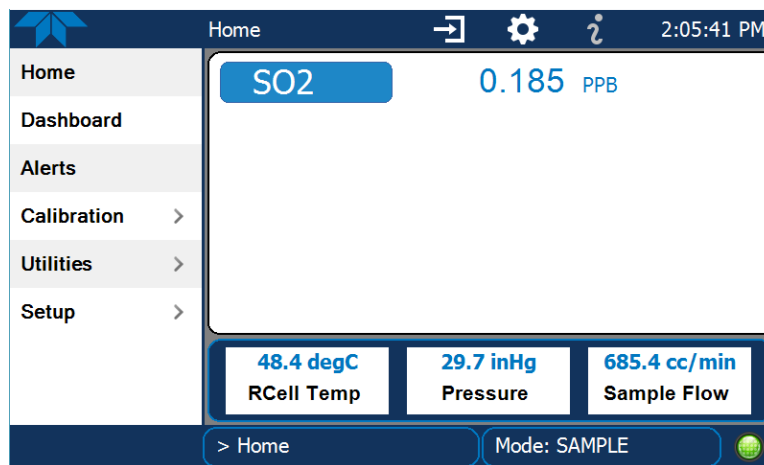

Figure 2-32. Home Page Example



2.3.4.2 ALERTS: WARNINGS AND OTHER MESSAGES

Because internal temperatures and other conditions may be outside the specified limits during the warm-up period, the software will suppress most Alerts for 30 minutes after power up. The Alerts page (Figure 2-33) shows the status of any active warning conditions or user-configured Events. (Section 2.4.3 provides more detailed information about Alerts, and Section 2.5.2 addresses Events).

Alerts can be viewed and cleared via either the Alerts menu or the Alerts shortcut (Caution symbol, bottom right corner of the screen). Although these alerts can be cleared from the Active Alerts page, a history of all alerts remains in the Utilities>Alerts Log page.

Navigate to the Active Alerts page via the Alerts menu on Home screen.

(Also view a list of all active and past Alerts and Events via Utilities>Alerts Log).

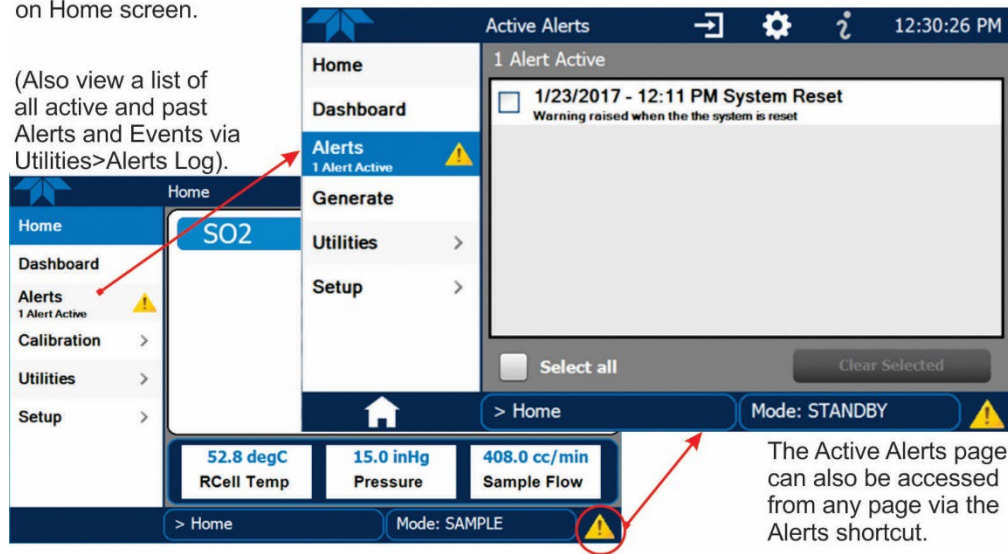

The Active Alerts page can also be accessed from any page via the Alerts shortcut.

Figure 2-33. Viewing Active Alerts Page

If alerts of warning conditions persist after the warm up period or after being cleared, investigate their cause using the troubleshooting guidelines in Section 5.7.



2.3.4.3 FUNCTIONAL CHECKS

After warm-up, verify that the software properly supports any hardware options that are installed (Setup>Instrument menu), and that the instrument is functioning within allowable operating parameters. Check the Dashboard page against the instrument's *Final Test and Validation Data sheet*, which lists these values as they appeared before the instrument left the factory. (If any functional parameters are not displayed, configure the Dashboard through the Setup>Dashboard menu to add them; see Section 2.4.2).

These functions are also useful tools for diagnosing problems (information provided in Section 5.7.2).

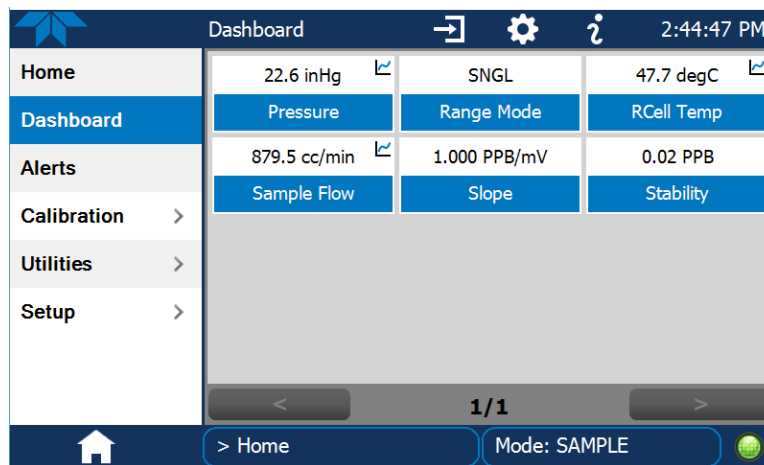

Figure 2-34. Sample Dashboard Page

2.3.4.4 CALIBRATION

Before operation begins, the analyzer requires zero and span calibrations, and possibly HVPS adjustment. Also, any time an analyzer is moved or its configuration changed, it must be calibrated. The method for performing a calibration differs slightly depending on whether or not any of the available internal zero air or valve options are installed. Follow the appropriate calibration instructions presented in Section 4.



2.4 MENU OVERVIEW

Table 2-9 describes the main menus and provides cross-references to the respective sections with configuration details.

Table 2-9. Menu Overview

MENU	DESCRIPTION	LOCATION
Home	View and plot concentration readings and other selectable parameter values (Figure 2-36).	Section 2.4.1
Dashboard	View user-selected parameters and their values, some of which can be displayed in a live-plot graph (Figure 2-37).	Section 2.4.2
Alerts	View and clear active Alerts that were triggered by factory-defined Events as well as user-defined Events. (Active and past Alerts are recorded in the Utilities>Alerts Log).	Section 2.4.3
Calibration	Run calibrations or calibration checks on the SO ₂ channel (and second gas sensor if installed).	Sections 2.4.4 and 4
Utilities	View logs, download data and firmware updates, copy configurations between instruments, and run diagnostics.	Section 2.4.5
Setup	Configure a variety of features and functions through these submenus for customized operation.	Section 2.5
Datalogging	Track and record concentration and calibration data and selectable diagnostic parameters, the reports for which can be viewed in the Utilities>Datalog View menu (Section 2.4.5) and downloaded to a flash drive via the Utilities>USB Utilities menu (Section 2.4.5). Also, select configured Events (Section 2.5.2) and create customized triggers for data logging functions.	Section 2.5.1
Events	Select parameters and define the conditions by which they are to be flagged and recorded in the Alerts log (Section 2.4.3) when they are triggered. Once configured, Events can be used to trigger Datalogs. (Section 2.5.1). Note that some Events are predefined and are not editable.	Section 2.5.2
Dashboard	Monitor instrument functionality (Figure 2-34) via selectable parameters.	Section 2.5.3
Auto Cal (with valve options)	When zero/span valve options installed, configure sequences for automatic calibration functions.	Section 4.6
Vars	Manually adjust several software variables that define specific operational parameters.	Section 2.5.5
Homescreen	Select up to three parameters to be displayed in the meters (Figure 2-35).	Section 2.5.6
Digital Outputs*	Map the rear-panel digital outputs to a variety of signals present in the instrument to monitor the status of operating conditions or custom Events.	Section 2.5.7
Analog Outputs*	Send user-selected parameter readings in the form of user-defined voltage or current loop signals as outputs to a strip chart recorder and/or the data logger.	Section 2.5.8
Instrument	View product and system information, including list of options, if any; view network settings; view/adjust Date and Time settings*; and check for firmware updates when connected to a network that is connected to the Internet. *Time Zone change requires special procedures (Section 5.5).	Section 2.5.9
Comm	View and configure network and serial communications.	Section 2.5.10

*The T100H includes an additional output, Vacuum Pressure, for pressure on vacuum side of critical flow orifice.



2.4.1 HOME PAGE

Figure 2-35 presents an orientation to the main display screen; Figure 2-36 shows that pressing the gas name or its concentration value or a meter below displays a live plot of their respective readings. Section 2.5.6 provides configuration instructions.

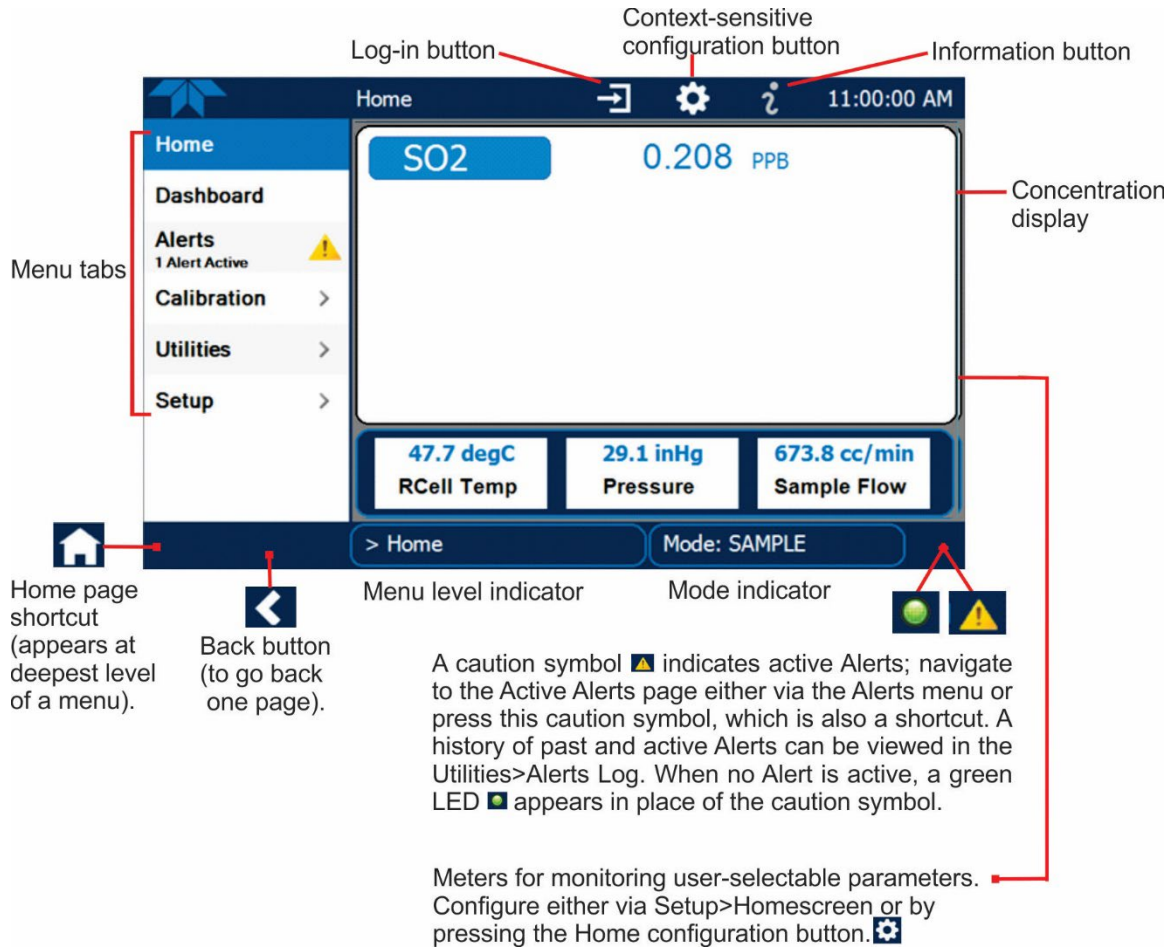
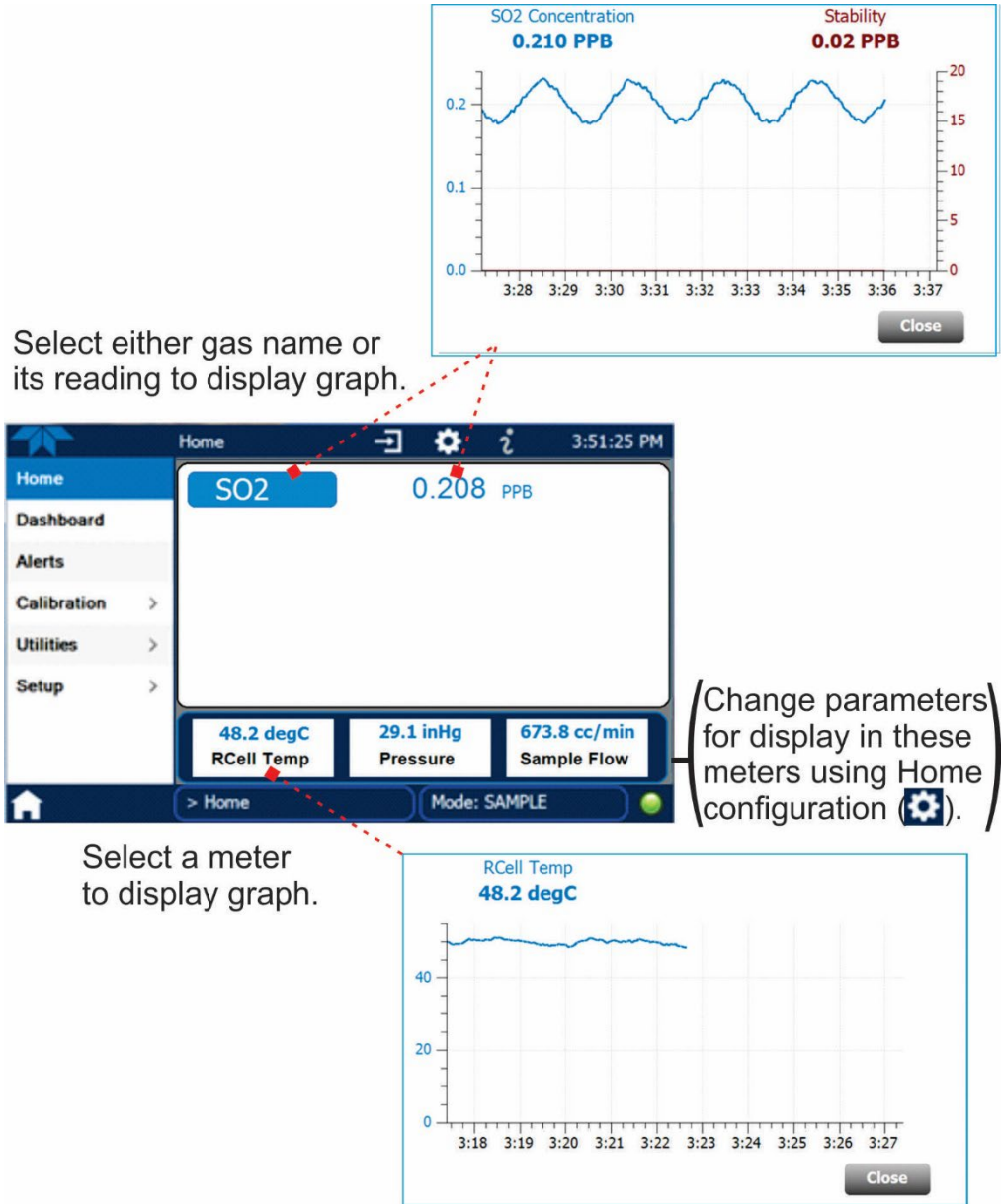

Figure 2-35. User Interface Orientation



T100, T100U, T100H



Select either gas name or its reading to display graph.

Select a meter to display graph.

(Change parameters for display in these meters using Home configuration (gear icon)).

Figure 2-36. Concentration and Stability Graph (top) and Meter Graph (bottom)



T100, T100U, T100H

2.4.2 DASHBOARD

The Dashboard displays an array of user-selectable parameters and their values (Section 2.5.3 provides configuration instructions). If there is a graphing icon in the upper right corner of a parameter, pressing that parameter displays a live plot of its readings as in Figure 2-37.

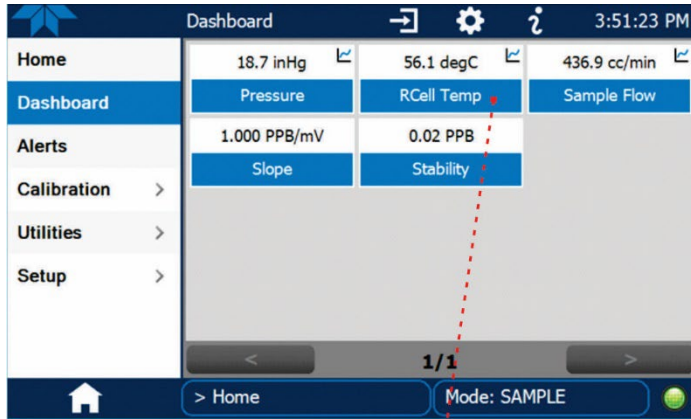

Select a graphable parameter in the Dashboard page to view a live plot.

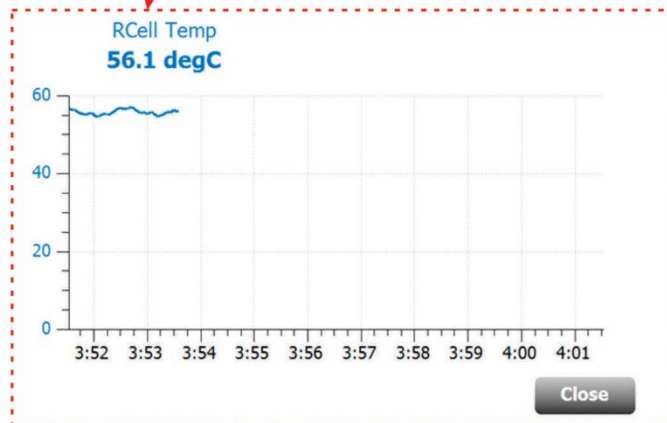

Figure 2-37. Dashboard Page

Common parameters and their descriptions are presented in Table 2-10.



T100, T100U, T100H

Table 2-10. Common Dashboard Parameters

PARAMETER	UNITS	DESCRIPTION
Box Temp	°C	The ambient temperature inside the analyzer chassis.
HVPS	V	The PMT high voltage power supply.
Offset	mV	The overall offset of the instrument as calculated during the last calibration activity. The offset parameter is used to set the zero point of the analyzer response.
PMT Signal	mV	The raw output voltage of the PMT.
PMT Dark	mV	The PMT output reading recorded the last time the UV source lamp shutter was closed.
PMT Temp	°C	The current temperature of the PMT.
RCell Temp	°C	The current temperature of the sample chamber.
Sample Flow	cm ³ /min (cc/m)	The flow rate of the sample gas through the sample chamber. This value is not measured but calculated from the sample pressure.
Sample Press	in-Hg-A	The current pressure of the sample gas as it enters the sample chamber, measured between the SO ₂ and Auto-Zero valves.
Slope	-	The sensitivity of the instrument as calculated during the last calibration activity. The slope parameter is used to set the span calibration point of the analyzer.
Stability	mV	Standard deviation of SO ₂ Concentration readings. Data points are recorded every ten seconds. The calculation uses the last 25 data points.
UV Lamp	mV	The output voltage of the UV reference detector.



2.4.3 ALERTS

Alerts are notifications triggered by specific criteria having been met by either factory-defined conditions (standard and not editable) or user-defined Events (Section 2.5.2). The Active Alerts page shows the status of any active warning conditions or Events that have been triggered.

When Alerts are triggered, a caution symbol appears in both the Alerts menu tab and in the bottom right corner of the software interface, which serves as a shortcut to the Alerts page from any other page. View a list of currently active Alerts by pressing either the Alerts menu on the Home screen or by pressing the Alerts shortcut (Figure 2-38).

While Alerts can be cleared from the Active Alerts page, they remain recorded in the Utilities>Alerts Log menu.

Navigate to the Active Alerts page via the Alerts menu on Home screen.

(Also view a list of all active and past Alerts and Events via Utilities>Alerts Log).

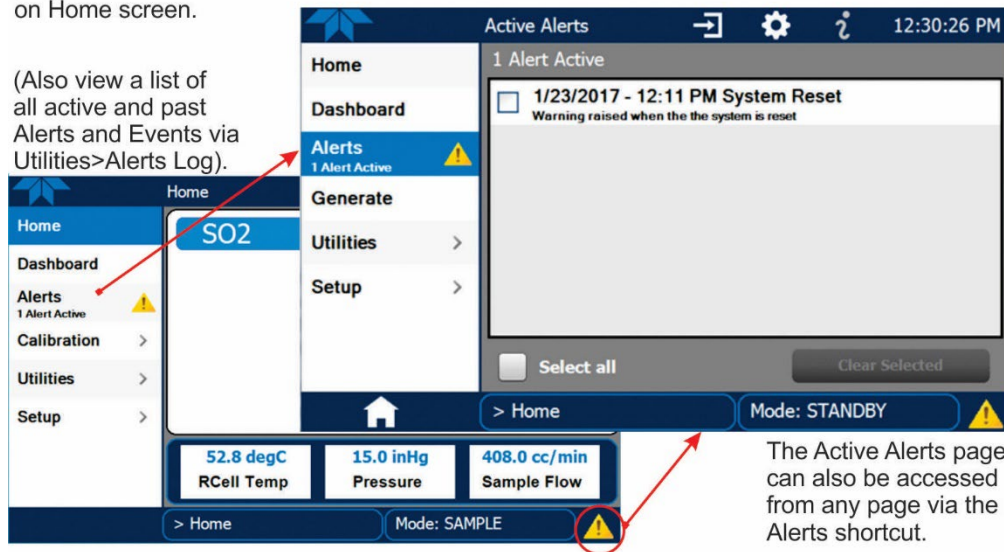

The Active Alerts page can also be accessed from any page via the Alerts shortcut.

Figure 2-38. Navigating to the Active Alerts Page

Alerts can be configured as either latching (appears in Active Alerts screen when Event is triggered and must be cleared by the user) or non-latching (Active Alerts screen continuously updates based on the Event criteria, clearing on its own). See Section 2.5.2.

To clear Alerts from the Active Alerts page, either check individual boxes to choose specific Alerts, or check the Select All box to choose all Alerts, then press the Clear Selected button.

When all Alerts are cleared, the Alerts menu tab no longer shows the caution symbol, and a green LED replaces the caution symbol in the bottom right corner of the interface (Figure 2-39). However, Alerts can reappear if the conditions causing them are not resolved. For troubleshooting guidance, refer to Section 5.7.

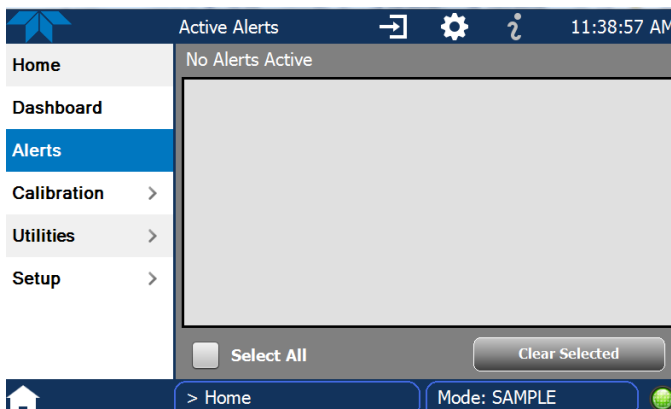

Figure 2-39. Active Alerts Cleared

Alerts and Events remain recorded in the Utilities>Alerts Log (Figure 2-40).

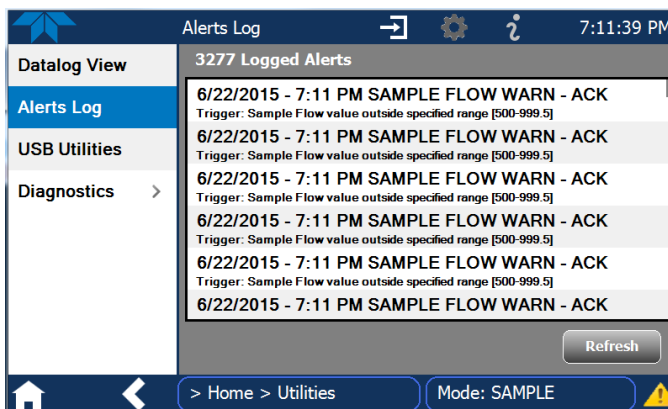

Figure 2-40. Utilities>Alerts Log of Active and Past Alerts and Events

2.4.4 CALIBRATION

The Calibration menu is used for multipoint calibrations and for external calibration with valve options installed. Calibration procedures are presented in Section 4.



2.4.5 UTILITIES

The Utilities menu has a variety of functions as described next in Table 2-11.

Table 2-11. Utilities Submenu Descriptions

UTILITIES MENU	DESCRIPTION
Datalog View	Displays the data logs that were configured via the Setup>Data Logging menu. From this list a log can be selected and filters applied to view the desired data. (For details on setting up and running the Data Logger, see Section 2.5.1).
Alerts Log	Displays a history of alerts that are triggered by factory-defined and user-defined Events, such as warnings and alarms (See Section 2.5.2 for Events configuration).
USB Utilities	Serves multiple purposes using a flash drive connected to the instrument's front panel USB port: <ul style="list-style-type: none"> • download data from the instrument's Data Acquisition System (DAS), the Data Logger, to a flash drive (Section 2.5.1.3) • update firmware (Section 5.3) • transfer instrument configuration from/to other same-model instruments (Section 2.6) • download a basic operation functionality report (Section 5.3).
Diagnostics	Provides access to various pages that facilitate troubleshooting.
Analog Inputs	Measure voltage signals of several analog input parameters. These can be logged in the internal data acquisition system (DAS), by configuring the Data Logger in the Setup>Data Logging menu (Section 2.5.1).
Analog Outputs	Show the voltage signals for the functions selected and configured in the Setup>Analog Outputs menu (Section 2.5.8). Rear panel connections were presented in Section 2.3.1.2.
Digital Inputs	Show whether specific available features are turned ON or OFF; for example, whether or not Maintenance Mode input or Language selection can be controlled through the front panel, or whether a zero or span calibration can be activated remotely when an external source is connected to the rear panel Control In connector (Section 2.3.1.5).
Digital Outputs	Show the function of user-specified parameters configured in the Setup>Digital Outputs menu (Section 2.5.7).
Flow Cal	Used to calibrate the sample gas flow reading with actual flow measured by an external device. (See Section 5.6.6.3).
OE Test	Used to run either an electrical test (ETest) or an optics test (OTest) (Section 5.7.8.10).

2.4.6 SETUP

The Setup menu is used to configure the instrument's software features, gather information on the instrument's performance, and configure and access data from the Datalogger, the instrument's internal data acquisition system (DAS). Section 2.5 provides details for the menus under Setup.



2.5 SETUP MENU: FEATURES/FUNCTIONS CONFIGURATION

Use the Setup menu to configure the instrument’s software features, to gather information on the instrument’s performance, and to configure and access data from the Datalogger, the instrument’s internal data acquisition system (DAS). Once the setups are complete, the saved configurations can be downloaded to a USB drive through the Utilities>USB Utilities menu and uploaded to other instruments of the same model (Section 2.6).

2.5.1 SETUP>DATA LOGGING (DATA ACQUISITION SYSTEM, DAS)

The Datalogger can be configured to capture and store user-defined data, which then can be viewed in the Alerts page, if elected, as well as downloaded from the instrument to a USB flash drive for examination and analysis.

Figure 2-41 shows a new log; Figure 2-42 shows a sample existing log, which can be edited or deleted, and Figure 2-43 provides illustrated instructions for setting up a new log, with Sections 2.5.1.1 and 2.5.1.2 providing additional details.

To transfer captured instrument data to a flash drive see Section 2.5.1.3.

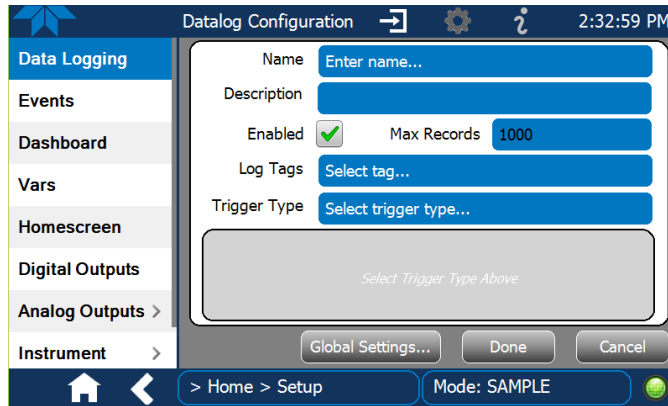

Figure 2-41. Datalog Configuration, New Log Page

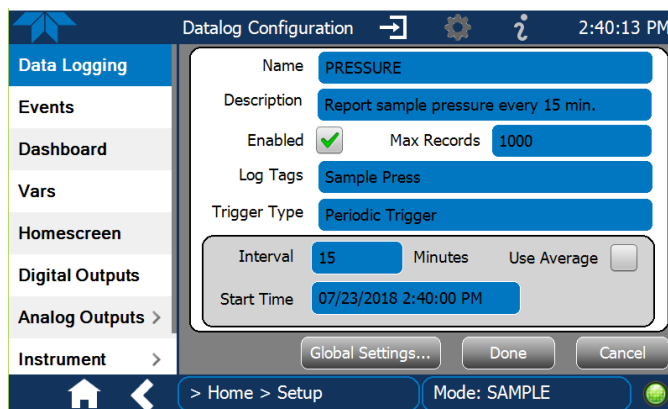

Figure 2-42. Datalog Configuration, Existing Log



T100, T100U, T100H

Press the Name field and use the keyboard pop-up to label the new log.

Press the Description field and use the keyboard pop-up to describe the log.

Press the Max Records field and use the keypad pop-up to set a maximum.

Leave the Enabled box checked to allow data capture of this log, or press to uncheck and suspend data capture.

Press the Log Tag field to select the parameters to be tracked.

Press the Trigger Type field to select either Periodic or Conditional.

Press Global Settings to set time format.

Datalog Global Settings

Time Format 12 hour 24 hour

12 hour

When **Periodic** is selected as the Trigger Type, the field below it is populated with the Interval and Date/Time windows.

Interval minutes

Start Time

When **Conditional** is selected as the Trigger Type, the field below it is populated with the Trigger Tag and Condition definition windows.

Trigger Tag

Condition

(Please refer to the section on Configuring Trigger Types for details).

Figure 2-43. Creating a New Data Log

The parameters available in the list of Log Tags include the names of Events configured in the Events page (Section 2.5.2).



2.5.1.1 CONFIGURING TRIGGER TYPES: PERIODIC

The Periodic trigger is a timer-based trigger that is used to log data at a specific time interval. Periodic Trigger requires an interval that is set to number of minutes and a start time that is set to date and clock time.

Press the Interval field and use the keypad pop-up to edit the amount of time in seconds (default 60) between capturing data for the selected Log Tags.

Press the Start Time field and use the Time and Date pop-ups to select the time and the date to start capturing data for the parameters that were selected in the Log Tags field.

(toggle)

Figure 2-44. Datalog Periodic Trigger Configuration



2.5.1.2 CONFIGURING TRIGGER TYPES: CONDITIONAL

Conditional Trigger tracks/records data for user-selected parameters that meet specified conditions.

Press the Trigger Tag field and select a parameter to be tracked/logged. A default Condition associated with the selected Tag will populate the Condition field.

Press the Condition field to select a different choice from the condition list.

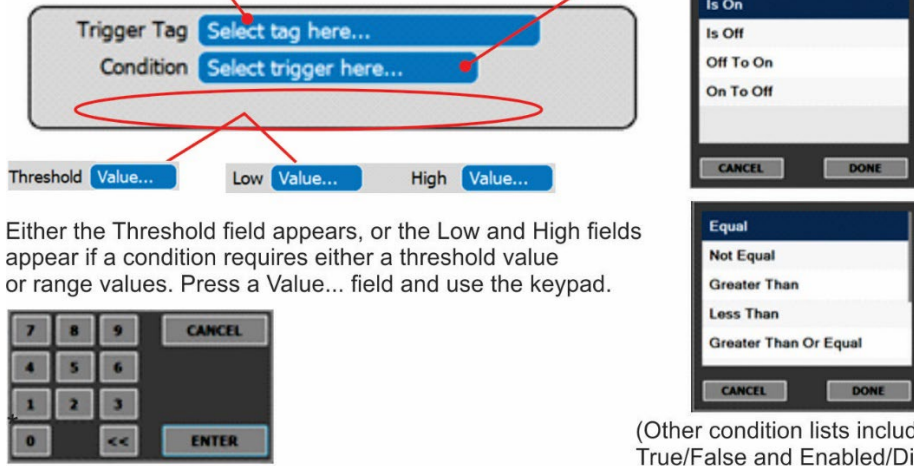

Figure 2-45. Datalog - Conditional Trigger Configuration

2.5.1.3 DOWNLOADING DAS (DATA ACQUISITION SYSTEM) DATA

To download DAS data collected by the Datalogger from the instrument to a flash drive, navigate to the Utilities>USB Utilities>DAS Download menu.

1. Insert a flash drive into a front panel USB port and wait for the Status field to indicate that the drive has been detected; available buttons will be enabled.

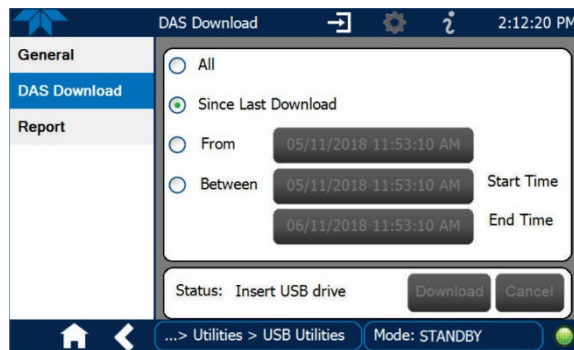

Figure 2-46. DAS Download Page

2. Select all or define a period from which to download the collected data.
3. Press the Download button, and when complete, as indicated in the Status field, press the Done button (changed from “Cancel”) and remove the flash drive.

2.5.2 SETUP>EVENTS

Events are occurrences that relate to any operating function, and are used to define the conditions that can be set to trigger Alerts (Section 2.4.3). Events can provide diagnostic information about the instrument, typically referred to as “Warnings”, or they can provide other information on instrument functionality, such as concentration alarms. Some Events are standard and not editable while others are user-configurable, described here. Existing Events are listed in the Events page (Figure 2-47) under the Setup menu.

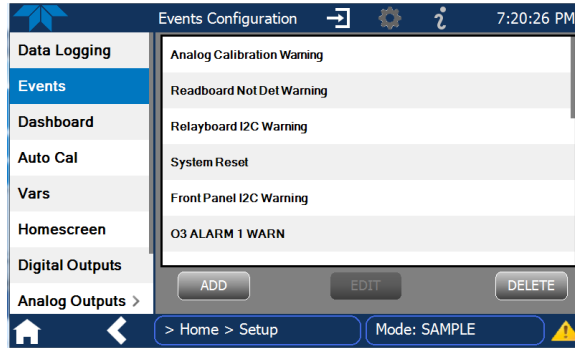

Figure 2-47. Events List

Access the Events Configuration page either from the Active Alerts page (Alerts Menu) by pressing the configuration button, or through the Home>Setup>Events menu (Figure 2-47). Press ADD to create a new Event (refer to Figure 2-48 for details), or select an existing Event to either Edit or Delete it (Figure 2-50).

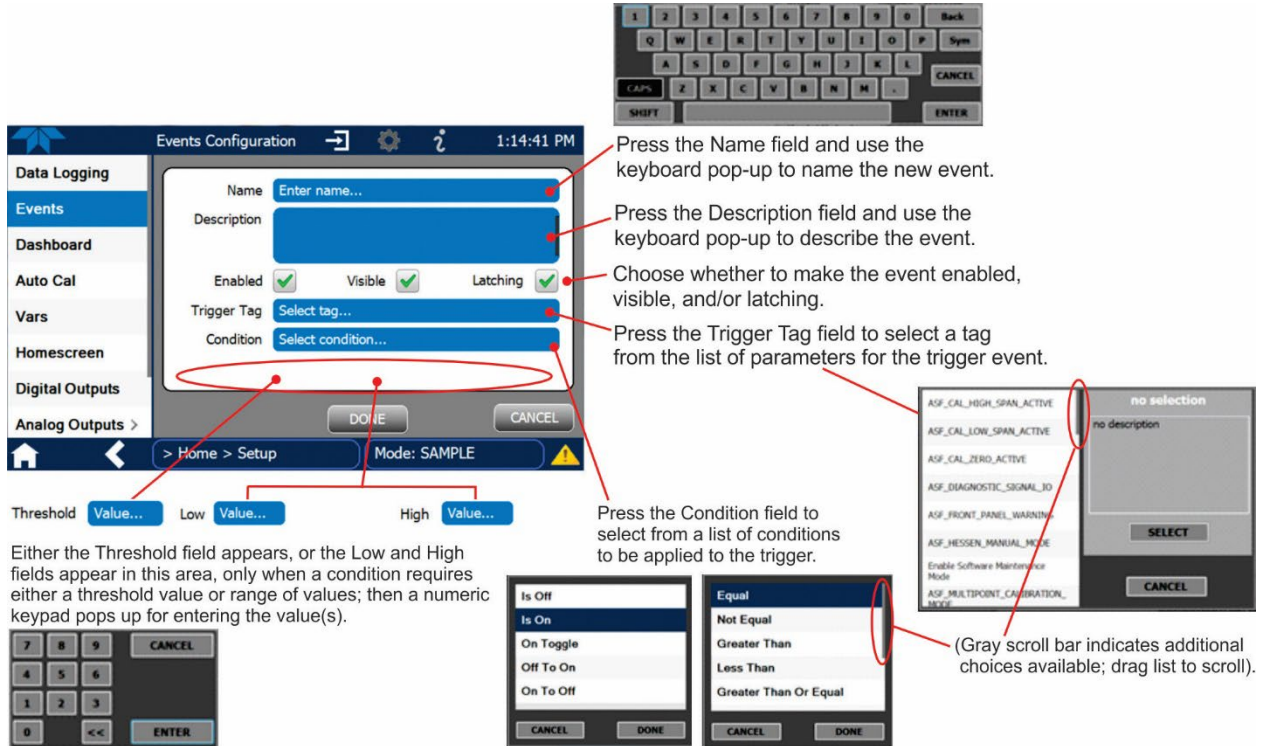

Figure 2-48. Event Configuration



T100, T100U, T100H

- Enabled allows the choice of whether to track and record the Event (uncheck this box to “turn off” or deactivate the Event without deleting it). An Event must be enabled in order to use the Visible and the Latching options.
- Visible allows the choice of whether or not to display the Event in the Alerts page when it is triggered (it will still be recorded and can be viewed in the Utilities>Alerts Log). To use this option, the Event must be enabled.
- Latching allows the choice of whether or not to keep an Event visible even if the conditions that triggered it were to correct themselves. (Latching requires that the user interact with the Active Alerts screen to manually clear the Alert and internal Event state. Non-latching allows the entry in the Active Alerts screen and the internal Event state to continuously update based on the Event criteria, requiring no user interaction to clear the Alert or Event state).

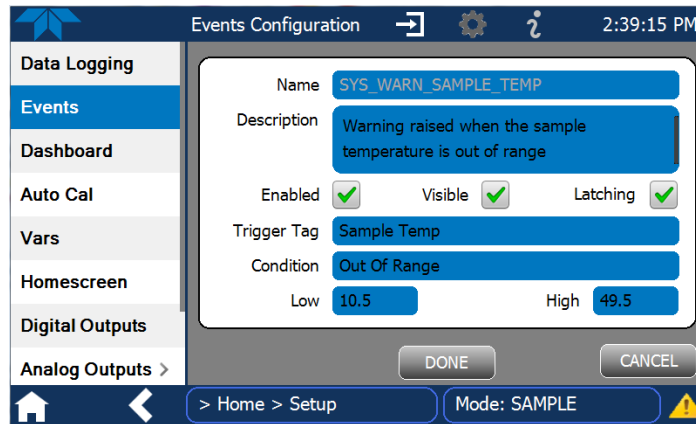

Figure 2-49. Configured Event Sample

2.5.2.1 EDITING OR DELETING EVENTS

Select an Event from the list (Figure 2-47) and press the Edit button to view or edit the details (Figure 2-49), or press the Delete button to delete the Event.

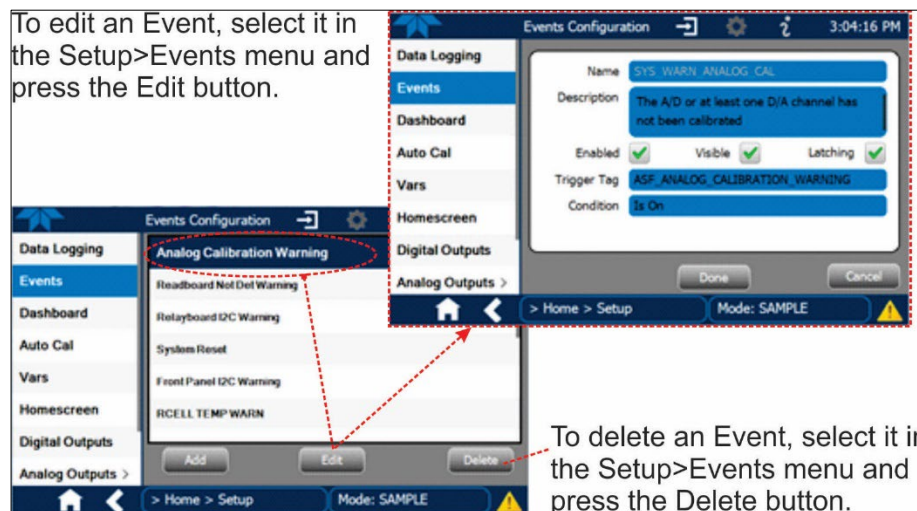

Figure 2-50. Edit or Delete an Event



2.5.2.2 USING EVENTS AS TRIGGERS FOR DATA LOGGING

Events can also be used to create customized triggers for data logging functions. The name entered in the Name field of the Events Configuration page will appear in the list of Log Tags of the Datalog Configuration page. The Data Logger is presented in Section 2.5.1.

2.5.3 SETUP>DASHBOARD

From Dashboard page, select the configuration shortcut, or navigate to Setup>Dashboard.

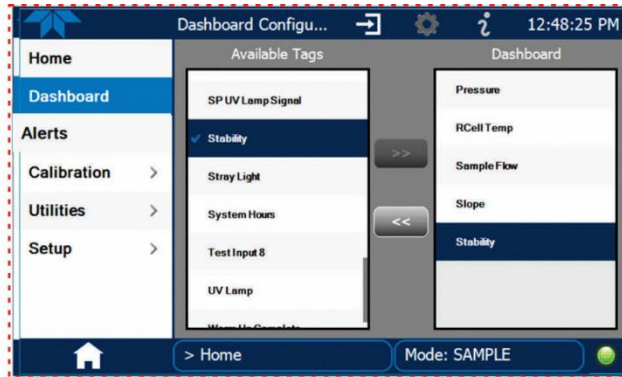

Configuration Shortcut

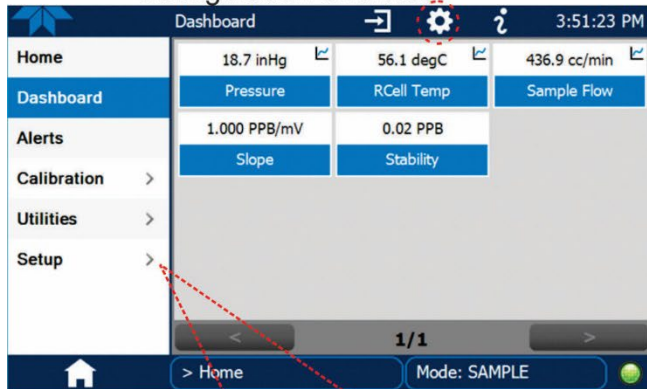

Configuration Editing:

To add a parameter to the Dashboard, select it in the “Available Tags” list and press the right-pointing arrows button. (Checkmarks in the “Available Tags” list indicate parameters that are currently in the Dashboard).

To remove a parameter from the Dashboard, select it from the “Dashboard” list and press the left-pointing arrows button.

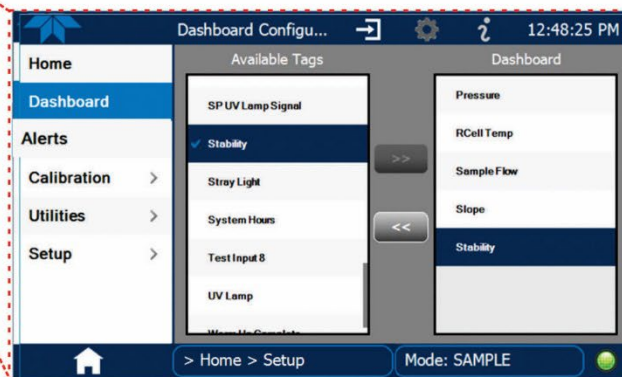

Figure 2-51. Dashboard Display and Configuration



2.5.4 SETUP>AUTO CAL (WITH VALVE OPTION)

Auto Cal is available with installed valve options (see Section 4.6).

2.5.5 SETUP>VARS

Vars are software variables that define operational parameters automatically set by the instrument’s firmware, and are user-adjustable through this menu. Access the menu to see the list of variables (Vars); select a Var to view its description; touch the Edit button to change its setting(s). Table 2-12 describes some of the Vars.

Table 2-12. Typical Variables with Descriptions

VARIABLE	DESCRIPTION
NOTE: This list includes several of the most common Vars; selecting any Var in the NumaView™ software interface will display its description in the information field to its right. Depending on configuration, some, all, or more of these variables appear in your instrument’s Vars menu.	
Background Periodic Report Upload	Allow a periodic report to be automatically uploaded to cloud service at a frequency (in hours) set in the Report Upload Interval var.
Daylight Savings Enable	Enable or disable Daylight Savings Time (also see Setup>Instrument>Date/Time Settings)
Dilution Factor Option	<p>Sets the instrument to compensate for diluted sample gas, such as in continuous emission monitoring (CEM) where the quality of gas in a smoke stack is being tested and the sampling method used to remove the gas from the stack dilutes the gas. Once the degree of dilution is known, this feature allows the user to add an appropriate scaling factor to the analyzer’s SO₂ concentration calculations so that the undiluted values for measurement range and concentration are shown on the instrument’s front panel display and reported via the instrument’s various outputs.</p> <ol style="list-style-type: none"> 1. Set the appropriate units of measure (Setup>Vars>User Units). 2. Select the reporting range mode (Setup>Vars>Range Mode) and set the reporting range upper limit (Setup>Analog Output). Ensure that the upper span limit entered for the reporting range is the maximum expected concentration of the undiluted gas. 3. Set the dilution factor as a gain, e.g., a value of 20 means 20 parts diluent and 1 part sample gas (Setup>Vars>Dilution Factor). 4. Calibrate the analyzer; ensure that the calibration span gas is either supplied through the same dilution system as the sample gas or has an appropriately lower actual concentration.
Dynamic Zero Enable	Dynamic zero automatically adjusts offset and slope of the SO ₂ response when performing a zero point calibration during an AutoCal (Section 4.6).
Dynamic Span Enable	Dynamic span automatically adjusts the offsets and slopes of the SO ₂ response when performing a span point calibration during an AutoCal (Section 4.6).
Enable Software Maintenance Mode	Set instrument to continue sampling, while ignoring calibration, diagnostic, and reset instrument commands. This feature is of particular use for instruments connected to Multidrop (2.3.1.7) or Hessen protocol networks.
Instrument ID	Set unique identifier number for the instrument when it is connected with other instruments in multidrop configuration or on the same Ethernet LAN, or when applying MODBUS or Hessen protocols (see Setup>Comm).
Max Concentration Range	Set the highest concentration expected, as this is used by the CPU to adjust Preamp physical ranges. (Section 4.4.5 provides more information).



T100, T100U, T100H

VARIABLE	DESCRIPTION
PRIGAS Precision	Sets the number of significant digits to the right of the decimal point display of primary gas concentration and stability values. (SECGAS Precision for secondary gas)
Range Mode	Controls range mode, single (SNGL) or dual (DUAL). (When set to DUAL, ensure that Max Concentration Range has been set).
System Hours	Total system runtime hours
TPC Enable	Enables or disables the Temperature and Pressure Compensation (TPC) feature (For information on TPC, see Section 6.6.3).
User Conc Units	Change the concentration units of measure.

2.5.6 SETUP>HOMESCREEN

To select a parameter (“tag”) for display in each of the three meters at the bottom of the Home page, navigate to the Homescreen configuration page through either the Setup>Homescreen menu or from Home page using the configuration icon (Figure 2-52).

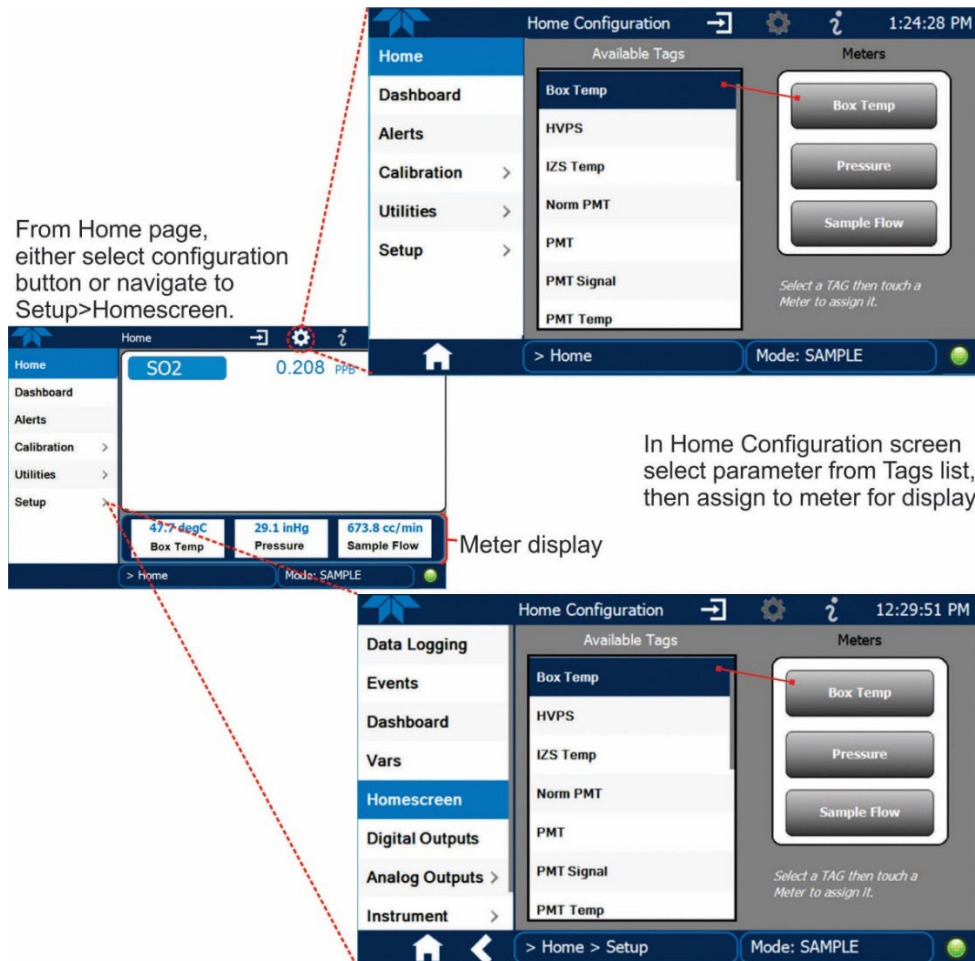

Figure 2-52. Homescreen Configuration

An orientation to the Homescreen was presented in Section 2.4.1, including Figure 2-35 and Figure 2-36.



2.5.7 SETUP>DIGITAL OUTPUTS

Specify the function of each digital output (connected through the rear panel STATUS connector) by mapping the output to a selection of “Signals” present in the instrument. Create custom “Signals” in the Setup>Events menu (Section 2.5.2). (If the Motherboard Relay Option was installed, the four additional relays can also be mapped).

To map Digital Outputs to Signals, select a pin in the Outputs list, then make a selection from the Signals list and press the Map button; if/as needed, change the polarity by pressing the Polarity button. Save any changes by pressing the Apply button, or discard the changes by pressing the Home or the back button (a pop-up provides a warning that the changes will be lost, and will prompt for confirmation to apply changes or not).

Go to the Utilities>Diagnostics>Digital Outputs menu to change the state (ON/OFF) of individual digital outputs.

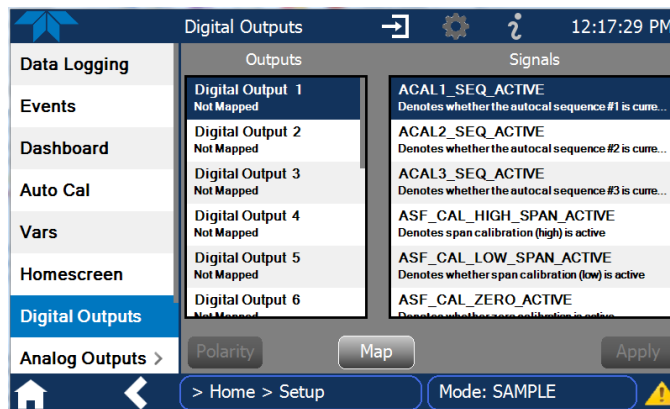

Figure 2-53. Digital Outputs Setup

2.5.8 SETUP>ANALOG OUTPUTS

Map the four user-configurable Analog Outputs to any of a wide variety of “Signals” present in the instrument and customize their respective configurations.

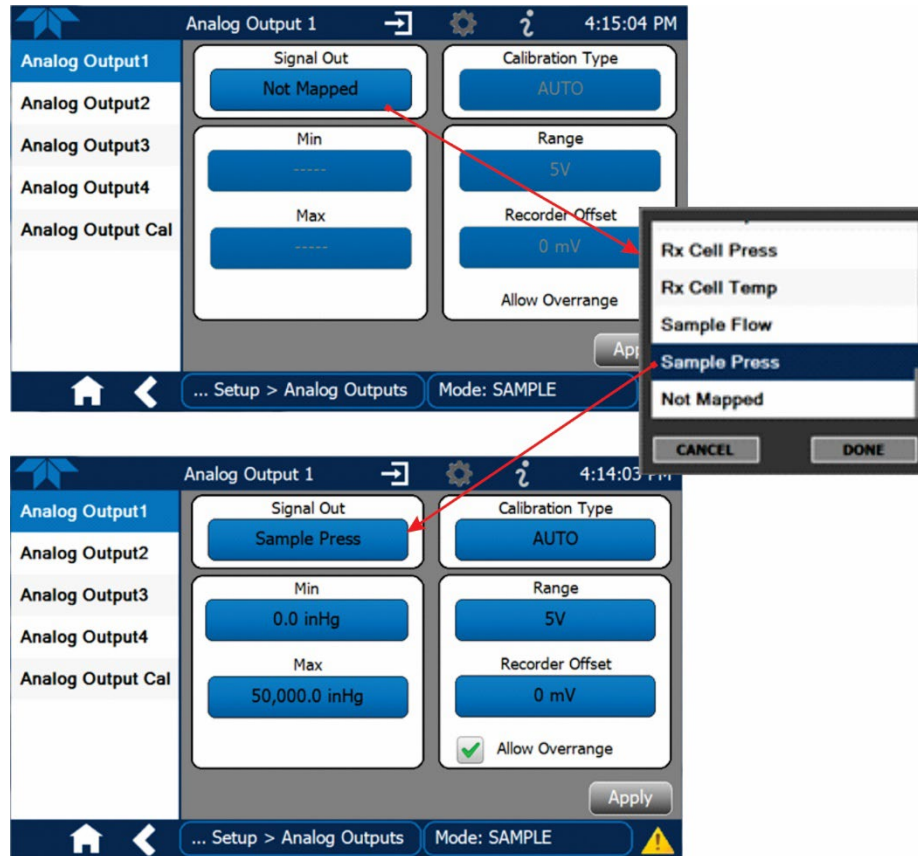

Figure 2-54. Analog Output Configuration Example

Refer to Figure 2-54 for the following:

- Signal Out: select a Signal for the output.
- Min/Max: edit minimum and maximum values associated with the selected Signal.
- Calibration Type:
 - AUTO for group calibration (Figure 2-55) of the analog outputs (cannot be selected when Current is selected for the Range)
 - MANUAL for individual calibration (Figure 2-56) of analog outputs where manual adjustments can be made (the only calibration type allowed when Current is selected for the Range). See Sections 2.5.8.1 and 2.5.8.2 .
- Range: assign a voltage or select Current (refer to Table 2-13).
- Recorder Offset: add a zero offset for recording slightly negative readings from noise around the zero point.
- Allow Overrange: check to allow a $\pm 5\%$ over-range; uncheck to disable over-range if the recording device is sensitive to excess voltage or current.

T100, T100U, T100H

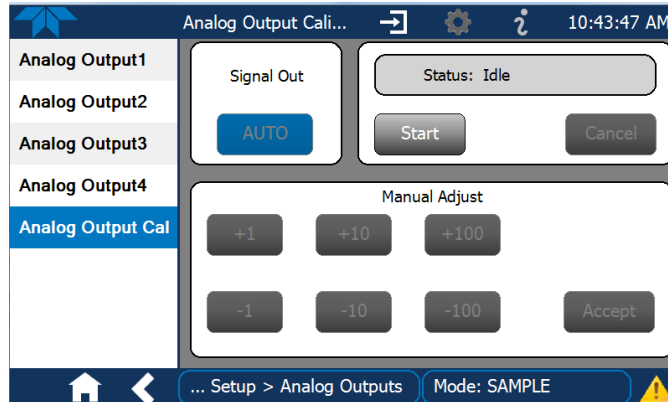

Figure 2-55. Analog Outputs Group Calibration Screen

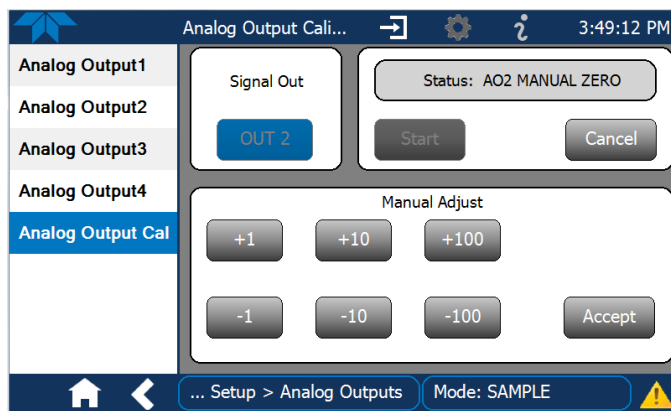

Figure 2-56. Analog Outputs Manual Calibration Screen (AOUT2 Example)

Table 2-13. Analog Output Voltage/Current Range

RANGE ¹	RANGE SPAN	MINIMUM OUTPUT	MAXIMUM OUTPUT
100mV	0-100 mVDC	-5 mVDC	105 mVDC
1V	0-1 VDC	-0.05 VDC	1.05 VDC
5V	0-5 VDC	-0.25 VDC	5.25 VDC
10V	0-10 VDC	-0.5 VDC	10.5 VDC
Current²	0-20 mA	0 mA	20 mA

¹ Each range is usable from -5% to +5% of the rated span.

² While these are the physical limits of the current loop modules, typical applications use 2-20 mA or 4-20 mA for the lower and upper limits.

For manual calibration adjustments, see Section 2.5.8.1 for voltage and Section 2.5.8.2 for current.



2.5.8.1 MANUAL CALIBRATION OF VOLTAGE RANGE ANALOG OUTPUTS

It is possible to manually calibrate the voltages by using a voltmeter connected across the output terminals (Figure 2-57) and changing the output signal level in the Manual Adjust field of the Analog Outputs Calibration screen (Figure 2-56). Refer to Table 2-14 for voltage tolerances.

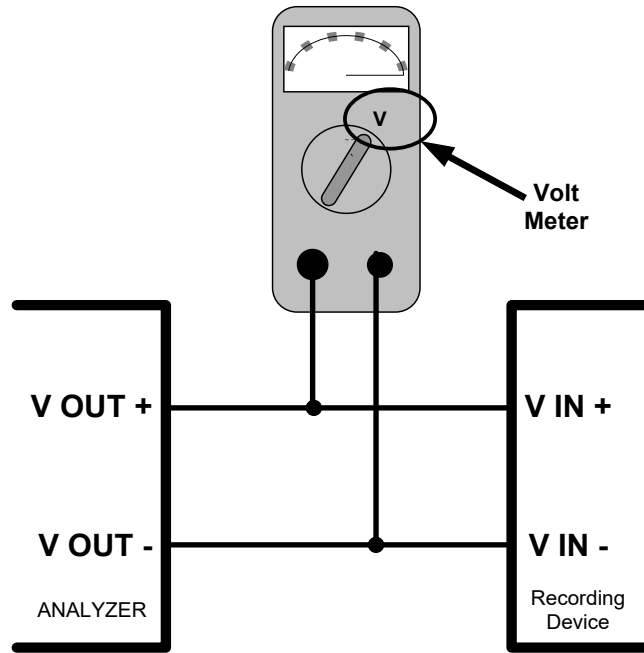

Figure 2-57. Setup for Checking / Calibrating DCV Analog Output Signal Levels

Table 2-14. Voltage Tolerances

FULL SCALE	ZERO TOLERANCE	SPAN VOLTAGE	SPAN TOLERANCE	MINIMUM ADJUSTMENT (1 count)
0.1 VDC	±0.0005V	90 mV	±0.001V	0.02 mV
1 VDC	±0.001V	900 mV	±0.001V	0.24 mV
5 VDC	±0.002V	4500 mV	±0.003V	1.22 mV
10 VDC	±0.004V	4500 mV	±0.006V	2.44 mV



2.5.8.2 MANUAL ADJUSTMENT OF CURRENT RANGE ANALOG OUTPUTS

These instructions assume that the Current Loop Option is installed (Section 2.3.1.3).

This option places circuitry in series with the output of the D-to-A converter on the motherboard that changes the normal DC voltage output to a 0-20 milliamp signal.

Adjusting the signal zero and span levels of the current loop output is done by raising or lowering the voltage output of the D-to-A converter circuitry on the analyzer's motherboard. This raises or lowers the signal level produced by the current loop option circuitry.

The software allows this adjustment to be made in 100, 10 or 1 count increments. Since the exact amount by which the current signal is changed per D-to-A count varies from output-to-output and instrument-to-instrument, you will need to measure the change in the signal levels with a separate, current meter placed in series with the output circuit. See Figure 2-6 for pin assignments and diagram of the analog output connector.

 **CAUTION!**
Do not exceed 60 V peak voltage between current loop outputs and instrument ground.

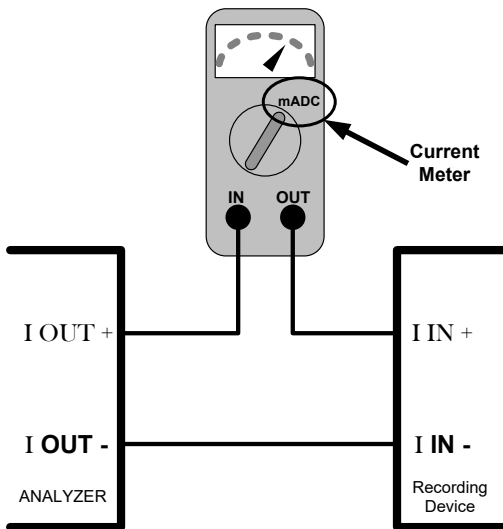

Figure 2-58. Setup for Checking / Calibration Current Output Signal Levels

An alternate method for measuring the output of the Current Loop converter is to connect a 250 ohm $\pm 1\%$ resistor across the current loop output in lieu of the current meter (see Figure 2-6 for pin assignments and diagram of the analog output connector). This allows the use of a voltmeter connected across the resistor to measure converter output as VDC or mVDC.



T100, T100U, T100H

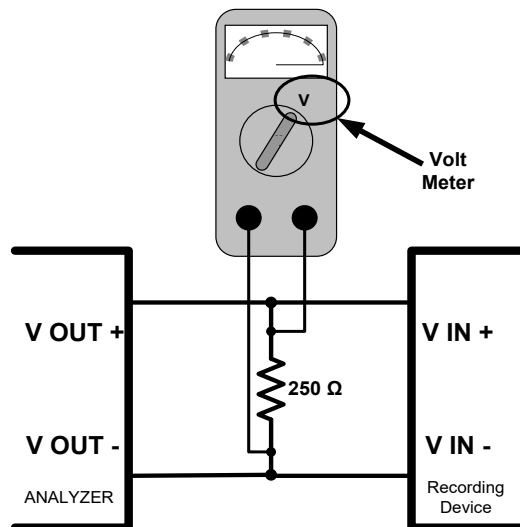

Figure 2-59. Alternative Setup Using 250Ω Resistor for Checking Current Output Signal Levels

In this case, follow the procedure above but adjust the output for the following values:

Table 2-15. Current Loop Output Check

% FS	Voltage across Resistor for 2-20 mA	Voltage across Resistor for 4-20 mA
0	500 mVDC	1000 mVDC
100	5000 mVDC	5000 mVDC

2.5.9 SETUP>INSTRUMENT

As presented in Table 2-16, view product and system information and network settings, edit network settings, and perform certain maintenance tasks.

Table 2-16. Setup>Instrument Menu

MENU	DESCRIPTION
Product Info	View Model, Part, and Serial Numbers and Package and Driver Versions, and options information.
System Info	View Windows and RAM information.
Network Settings	View the network settings (configurable through the Setup>Comm>Network Settings menu).
Date/Time Settings	Adjust date, hour, and minutes, select a time zone*, and set the system clock to automatically adjust for Daylight Savings Time or not. (Also see Setup>Vars>Daylight Savings Enable). *Time Zone change requires a special procedure; see Maintenance Section 5.5.
NTP Time Settings	Configure Network Time Protocol settings for clock synchronization.
Language	Select an available language.
Remote Update	When an instrument is connected to a network that is connected to the Internet, follow the instructions on this Remote Update page to check for and activate software/firmware updates. (Also refer to Section 5.3).



T100, T100U, T100H

2.5.10 SETUP>COMM (COMMUNICATIONS)

This menu is for specifying the various communications configurations.

2.5.10.1 COM1/COM2

Configure the instrument's COM1 or COM2 ports to operate in modes listed in Table 2-17.

Table 2-17. COM1/COM2 Configuration

MODE	DESCRIPTION
Baud Rate	Set the baud rate for the COM1 or COM2 port being configured.
Command Prompt Display	Enable/disable a command prompt to be displayed when in terminal mode.
Data Bits	Set the data bits to 7 or 8 (typically set in conjunction with Parity and Stop bits).
Echo and Line Editing	Enable/disable character echoing and line editing.
Handshaking Mode	Choose SOFTWARE handshaking for data flow control (do NOT use SOFTWARE handshaking mode when using MODBUS RTU for Protocol mode; select only HARDWARE or OFF for MODBUS RTU), or HARDWARE for CTS/RTS style hardwired transmission handshaking. (This style of data transmission handshaking is commonly used with modems or terminal emulation protocols). Or choose to turn OFF handshaking.
Hardware Error Checking	Enable/disable hardware error checking.
Hardware FIFO	Enable/disable the hardware First In – First Out (FIFO) for improving data transfer rate for that COM port.
Modem Connection	Select either a modem connection or a direct cable connection.
Modem Init String	Input an initialization string to enable the modem to communicate.
Multidrop	Enable/disable multidrop mode for multi-instrument configuration on a single communications channel. Multidrop requires a unique ID for each instrument in the chain (Setup>Vars>Instrument ID).
Parity	Select odd, or even, or no parity (typically set in conjunction with Data Bits and Stop Bits).
Protocol	Select among the communications protocols: TAPI, Hessen, MODBUS RTU, or MODBUS ASCII (MODBUS: Section 3.7.1; Hessen: Section 3.7.2).
Quiet Mode	Enable/disable Quiet mode, which suppresses any feedback from the analyzer (such as Alerts) to the remote device and is typically used when the port is communicating with a computer program where such intermittent messages might cause communication problems. Such feedback is still available, but a command must be issued to receive them.
RS-485	Enable/disable the rear panel COM2 Port for RS-485 communication. RS-485 mode has precedence over Multidrop mode if both are enabled. Also, RS-485 configuration disables the rear panel USB port.
Security	Enable/disable the requirement for a password for this serial port to respond. The only command that is active is the request-for-help command (? CR).
Stop bits	Select either 0 or 1 stop bit (typically set in conjunction with Parity and Data bits).



2.5.10.2 TCP PORT1

TCP Port1 allows choosing whether or not to display the command prompt, editing the Port 1 number for defining the terminal control port by which terminal emulation software addresses the instrument, such as Internet or NumaView™ Remote software, and enabling or disabling security on this port.

2.5.10.3 TCP PORT2

TCP Port2 is configured with the port number for MODBUS.

2.5.10.4 TCP PORT3

TCP Port3 is configured with the port number for Hessen.

2.5.10.5 NETWORK SETTINGS

The Setup>Comm>Network Settings menu is for Ethernet configuration. The address settings default to automatic configuration by Dynamic Host Configuration Protocol (DHCP). Most users will want to configure the instrument with a static IP address: click the Static radio button to manually assign a static IP address (consult your network administrator, and see Table 2-18 for information).

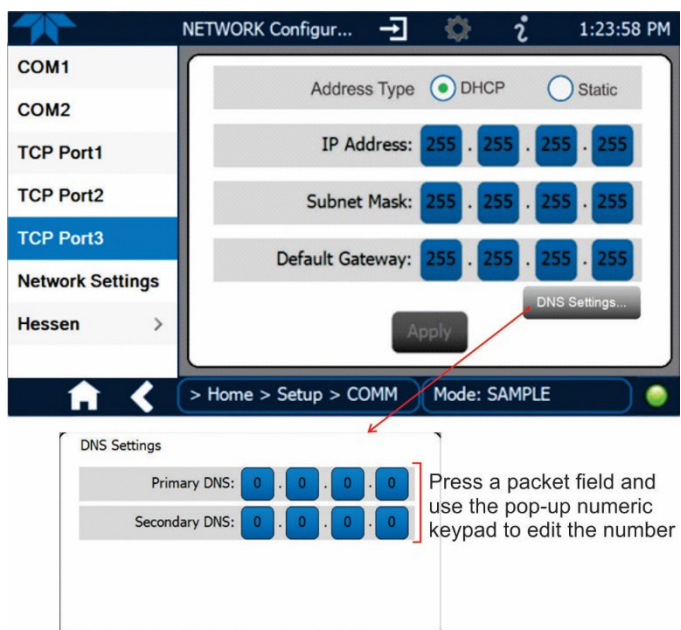

Figure 2-60. Communications Configuration, Network Settings

Table 2-18. LAN/Ethernet Configuration Properties

PROPERTY	DESCRIPTION
IP address	A string of four packets of 1 to 3 numbers each (e.g. 192.168.76.55.) is the internet protocol address of the instrument itself.
Subnet Mask	A string of four packets of 1 to 3 numbers each (e.g. 255.255.252.0) number that masks an IP address, and divides the IP address into network address and host address and identifies the LAN to which the device is connected. All addressable devices and computers on a LAN must have the same subnet mask. Any transmissions sent to devices with different subnets are assumed to be outside of the LAN and are routed through the gateway computer onto the Internet.
Default Gateway	A string of numbers very similar to the Instrument IP address (e.g. 192.168.76.1.) that is the address of the computer used by your LAN and serves as a router to access the Internet or another network.

2.6 TRANSFERRING CONFIGURATION TO OTHER INSTRUMENTS

Once an instrument is configured, the same configuration can be copied to other instruments of the same Model. This encompasses essentially anything the user can configure and does not apply to instrument-specific settings such as those that are configured at the factory for calibration.

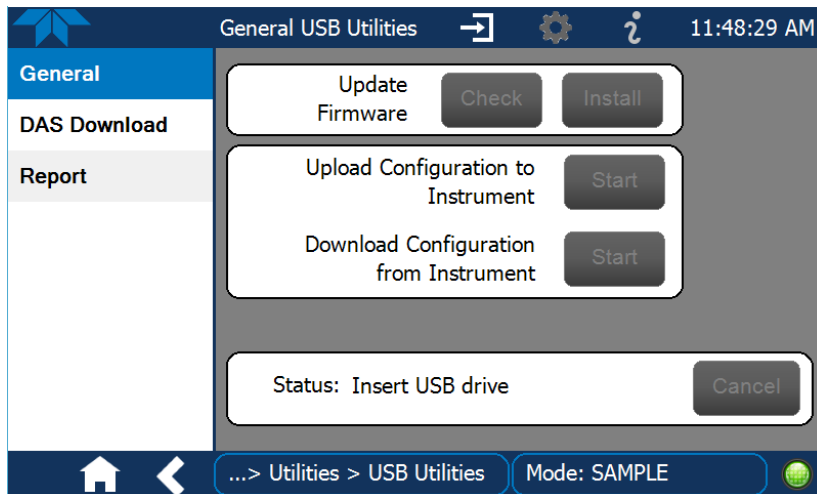

Figure 2-61. Configuration Transfer

1. In the source instrument, go to the Home>Utilities>USB Utilities>General page.
2. Insert a flash drive into either of the two front panel USB ports.
3. When the Status field indicates that the USB drive has been detected, press the “Download Configuration from Instrument” Start button.
4. When the Status field indicates that the download is complete, remove the flash drive.
5. In the target instrument, go to the Home>Utilities>USB Utilities>General page.



T100, T100U, T100H

6. Insert a flash drive into either of the two front panel USB ports.
7. When the Status field indicates that the USB drive has been detected, press the “Upload Configuration to Instrument” Start button.
8. When the Status field indicates that the upload is complete, remove the flash drive.



3 COMMUNICATIONS AND REMOTE OPERATION

This instrument's rear panel connections include an Ethernet port, a USB port (option) and two serial communications ports labeled RS232, which is the COM1 port in the software menu, and COM2 (refer to Figure 2-2). These ports allow the ability to communicate with, issue commands to, and receive data from the analyzer through an external computer system or terminal. Connection instructions were provided in Section 2.3.1.7. Configuration information was provided in Section 2.5.10.

This section provides pertinent information regarding communication equipment, the communications ports, and communications protocol. Data acquisition is set up through the Datalogger (Section 2.5.1).

3.4 DATA TERMINAL/COMMUNICATION EQUIPMENT (DTE DCE)

RS-232 was developed for allowing communications between data terminal equipment (DTE) and data communication equipment (DCE). Basic terminals always fall into the DTE category whereas modems are always considered DCE devices. The difference between the two is the pin assignment of the Data Receive and Data Transmit functions.

- DTE devices receive data on pin 2 and transmit data on pin 3.
- DCE devices receive data on pin 3 and transmit data on pin 2.

To allow the analyzer to be used with terminals (DTE), modems (DCE) and computers (which can be either), a switch mounted below the serial ports on the rear panel, labeled DCE DTE (Figure 2-2), allows the user to set the RS-232 configuration for one of these two data devices. This switch exchanges the Receive and Transmit lines on RS-232 emulating a cross-over or null-modem cable. The switch has no effect on COM2.

3.5 MODES, BAUD RATE AND SERIAL COMMUNICATION

Referring to Table 2-17, use the SETUP>COMM menu to configure COM1 (labeled RS232 on instrument rear panel) and/or COM2 (labeled COM2 on instrument rear panel) for communication modes, baud rate and serial communications. If using a USB option communication connection, setup requires that the instrument's baud rate and personal computer baud rate match.



3.5.1 SERIAL COMMUNICATION: RS-232

The RS232 and COM2 communications ports operate on the RS-232 protocol (default configuration). Configurations possible for these two ports are:

- RS232 port can also be configured to operate in single or RS-232 Multidrop mode (Option 62); refer to Section 2.3.1.7.
- COM2 port can be left in its default configuration for standard RS-232 operation including multidrop, or it can be reconfigured for half-duplex RS-485 operation (please contact the factory for this configuration).

Note

When the rear panel COM2 port is in use, except for multidrop communication, the rear panel USB port cannot be used. (Alternatively, when the USB port is enabled, COM2 port cannot be used except for multidrop).

A code-activated switch (CAS), can also be used on either port to connect typically between 2 and 16 send/receive instruments (host computer(s) printers, data loggers, analyzers, monitors, calibrators, etc.) into one communications hub. Contact Teledyne API Sales (front cover, this manual) for more information on CAS systems.

3.5.2 SERIAL COMMUNICATION: RS-485 (OPTION)

The COM2 port of the instrument’s rear panel is set up for RS-232 communication but can be reconfigured for RS-485 communication. Contact Technical Support for reconfiguration unless this option was elected at the time of purchase, then the rear panel was preconfigured at the factory.

3.6 ETHERNET

When using the Ethernet interface, the analyzer can be connected to any standard 10BaseT or 100BaseT Ethernet network via low-cost network hubs, switches or routers. The interface operates as a standard TCP/IP device on port 3000. This allows a remote computer to connect through the network to the analyzer using NumaView™ Remote, terminal emulators or other programs.

The Ethernet connector has two LEDs that are on the connector itself, indicating its current operating status.

Table 3-1. Ethernet Status Indicators

LED	FUNCTION
amber (link)	On when connection to the LAN is valid.
green (activity)	Flickers during any activity on the LAN.

The analyzer is shipped with DHCP enabled by default. This allows the instrument to be connected to a network or router with a DHCP server; however, it should be configured with a Static IP address as soon as practical. See Section 2.5.10.5 for configuration details.



3.7 COMMUNICATIONS PROTOCOLS

MODBUS (Section 3.7.1) and Hessen (Section 3.7.2) are available with the analyzer. MODBUS registers are provided in Appendix A.

3.7.1 MODBUS

These instructions assume that the user is familiar with MODBUS communications, and provide minimal information to get started. Please refer to the Teledyne API MODBUS manual, PN 06276, and to www.modbus.org for MODBUS communication protocols.

Minimum Requirements:

- Instrument firmware with MODBUS capabilities installed
- MODBUS-compatible software (TAPI uses MODBUS Poll for testing; see www.modbustools.com)
- Personal computer with communications cable (Ethernet or USB or RS232), and possibly a null modem adapter or cable

3.7.1.1 MODBUS COM PORT CONFIGURATION

MODBUS communications can be configured for transmission over Ethernet or serial COM port through the Setup>Comm menu. Make the appropriate cable connections (Ethernet or COM port) between the instrument and a PC.

Check the instrument's Modbus Units selection in the Setup>Vars menu and edit if needed.

Ethernet: MODBUS is available on TCP port 502. By default, port 502 is assigned to the instrument's TCP Port 2. (Setup>Comm> TCP Port2, Figure 3-1).

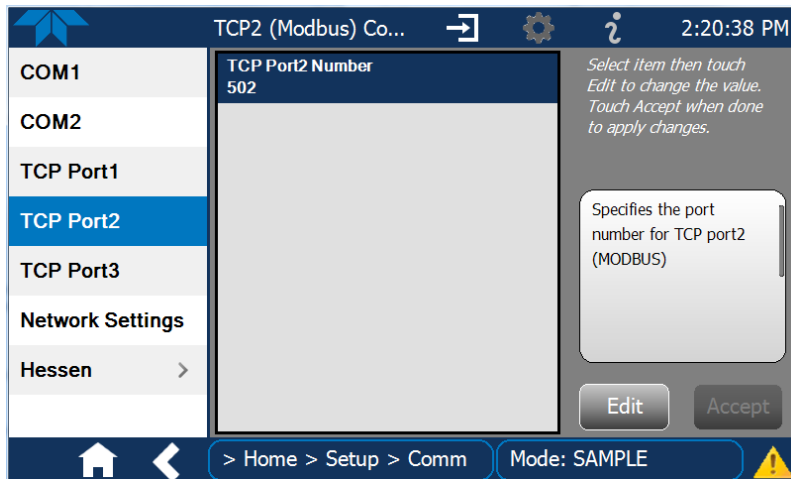

Figure 3-1. MODBUS via Ethernet



T100, T100U, T100H

Serial COM: Both COM1 (labeled “RS232” on the instrument’s rear panel) and COM2 are configurable for RS-232 or RS-485 communication with either MODBUS RTU or MODBUS ASCII transmission modes. In the Setup>Comm COM1[COM2] menu, edit the Protocol parameter to select a MODBUS transmission mode; edit Baud Rate, Parity, Data Bits, etc., if necessary (see descriptions in Table 2-17).

Important

When using MODBUS RTU, ensure that the COM1[COM2] Handshaking Mode is set to either Hardware or OFF. Do NOT set it to Software.

Press the Accept button to apply the settings. (Figure 3-2 shows an example for MODBUS RTU).

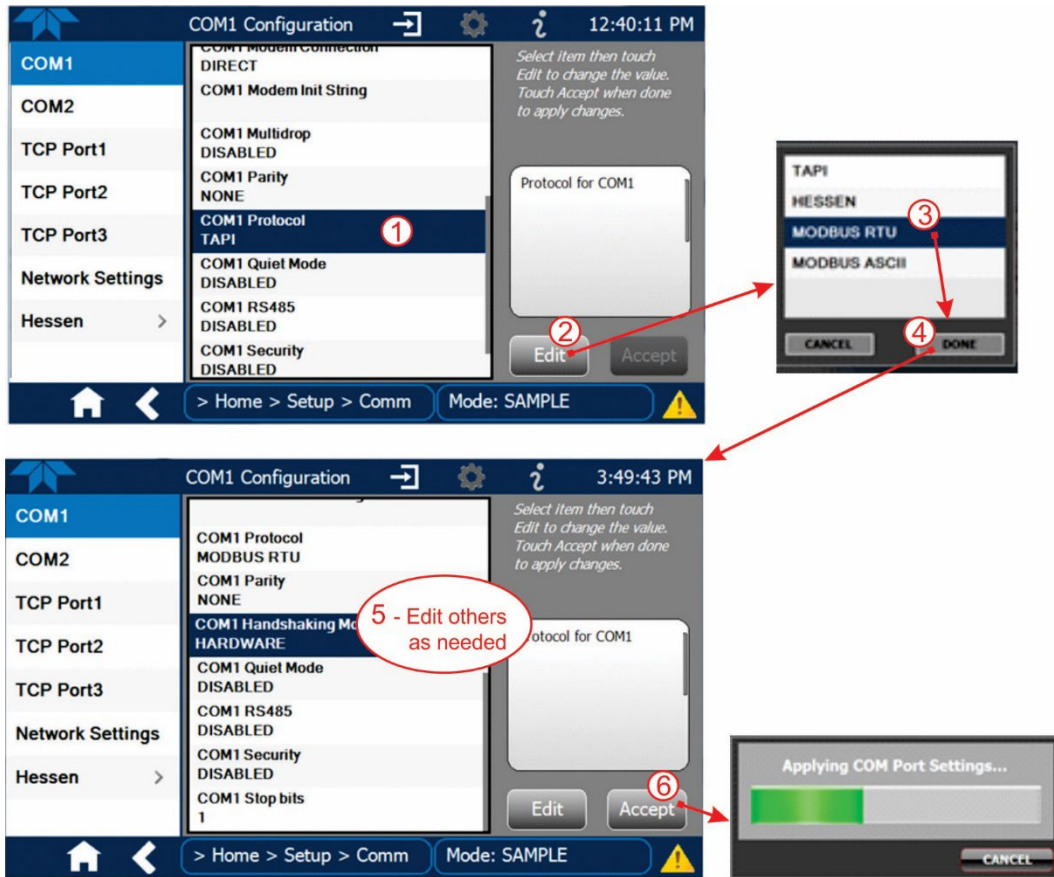

Figure 3-2. MODBUS via Serial Communication (example)

Important

When more than one analyzer is connected to the network, create a unique identification number for each in the Setup>Vars>Instrument ID menu.

Next, for the settings to take effect, power off the analyzer, wait 5 seconds, and power it on again.



3.7.2 HESSEN

Hessen is a multidrop protocol, in which several remote instruments (slaves) are connected via a common communications channel to a host computer. Slaves respond only to commands sent by the host using their unique identification.

Important Create a unique identification number for each instrument in the multidrop chain via the Setup>Vars>Instrument ID menu.

The Hessen protocol is not strictly defined; therefore, while Teledyne API's application is completely compatible with the protocol itself, it may be different from implementations by other companies.

3.7.2.1 HESSEN COM PORT CONFIGURATION

Configure the COM1/COM2 port for Hessen protocol through the Setup>Comm>COM1[COM2] menu: select COM1[COM2] Protocol and press Edit to select HESSEN, then press Accept.

Ensure that the communication parameters of the host computer are also properly set.

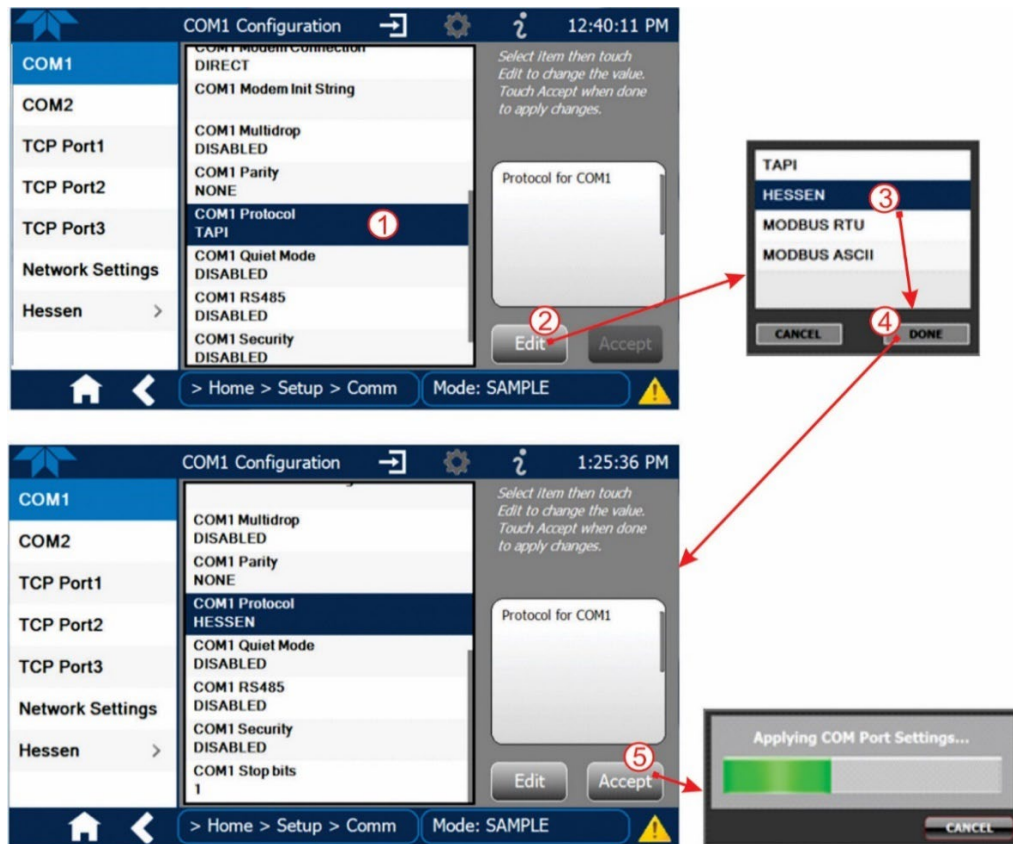

Figure 3-3. Serial Communication, Setting Hessen Protocol

Note The instrument software has a 200 ms latency period before it responds to commands issued by the host computer. This latency should present no problems, but be mindful of issuing commands to the instrument too frequently.



3.7.2.2 HESSEN SETTINGS CONFIGURATION

Hessen configuration includes settings for alarms, version, response mode, status flags and gas list. Locate the alarms in the Hessen Settings list (Setup>Comm>Hessen>Hessen Settings) and edit as desired.

HESSEN VARIATION

For the Hessen Variation setting, there are two versions.

- TYPE 1 is the original implementation.
- TYPE 2 has more flexibility when operating with instruments that can measure more than one type of gas. For more specific information about the difference between the two versions, download the *Manual Addendum for Hessen Protocol* from the Teledyne API's web site: <http://www.teledyne-api.com/manuals/>.

HESSEN PROTOCOL RESPONSE MODE

Set the response mode under Hessen Response Mode, referring to Table 3-2 for descriptions.

Table 3-2. Teledyne API's Hessen Protocol Response Modes

MODE ID	MODE DESCRIPTION
CMD	This is the default setting. Responses from the instrument are encoded as the traditional command format. Style and format of responses depend on exact coding of the initiating command.
BCC	Responses from the instrument are always delimited with <STX> (at the beginning of the response, <ETX> (at the end of the response followed by a 2 digit Block Check Code (checksum), regardless of the command encoding.
TEXT	Responses from the instrument are always delimited with <CR> at the beginning and the end of the string, regardless of the command encoding.

HESSEN STATUS FLAGS

Locate the various status flags in the Hessen Settings list and edit as needed. They are listed by status flag name with their default bit assignments. (Those with unassigned flags are listed as "0x0000").

- The status bits are included in the instrument's responses to inform the host computer of its condition. Each bit can be assigned to one operational and warning message flag.
- It is possible to assign more than one flag to the same Hessen status bit. This allows the grouping of similar flags, such as all temperature warnings, under the same status bit.
- Assigning conflicting flags to the same bit will cause each status bit to be triggered if any of the assigned flags is active.



T100, T100U, T100H

Table 3-3. T100, T100U Hessen Status Flags and Default Bit Assignments

STATUS FLAG NAME	DEFAULT BIT ASSIGNMENT (user editable; also see Note ²)
WARNING FLAGS	
SAMPLE FLOW WARNING	0001
PMT DET WARNING	0002
UV LAMP WARNING	0002
HVPS WARNING	0004
DARK CAL WARNING	0008
RCELL TEMP WARNING	0010
IZS TEMP WARNING ¹	0020
PMT TEMP WARNING	0040
INVALID CONC	0080
OPERATIONAL FLAGS	
In Manual Calibration Mode	0200
In Zero Calibration Mode	0400
In Span Calibration Mode	0800
UNITS OF MEASURE FLAGS	
UGM	0000
MGM	2000
PPB	4000
PPM	6000
Spare/Unused Bits	100. 8000
UNASSIGNED FLAGS	
Box Temp Warning	MP Calibration
Sample Press Warning	Analog Cal Warning
System Reset	Cannot Dyn Zero
Rear Board Not Detected	Cannot Dyn Span
Relay Board Warning	Instrument Off

¹ Only applicable if the optional internal span gas generator is installed.

² It is possible to assign more than one flag to the same Hessen status bit. This allows the grouping of similar flags, such as all temperature warnings, under the same status bit.

Be careful not to assign conflicting flags to the same bit as each status bit will be triggered if any of the assigned flags is active.



T100, T100U, T100H

Table 3-4. T100H Hessen Status Flags and Default Bit Assignments

STATUS FLAG NAME	DEFAULT BIT ASSIGNMENT
WARNING FLAGS	
SAMPLE FLOW WARNING	0001
PMT DET WARNING	0002
UV LAMP WARNING	0002
HVPS WARNING	0004
DARK CAL WARNING	0008
RCELL TEMP WARNING	0010
PMT TEMP WARNING	0040
INVALID CONC	0080
OPERATIONAL FLAGS	
In Manual Calibration Mode	0200
In Zero Calibration Mode	0400
In Low Span Calibration Mode	0800
In Span Calibration Mode	0800
UNITS OF MEASURE FLAGS	
UGM ¹	0000
MGM	2000
PPB ¹	4000
PPM	6000
SPARE/UNUSED BITS	0020, 0100, 8000
UNASSIGNED FLAGS	
Box Temp Warning	System Reset
Sample Press Warning	Front Panel Warning
Vacuum Press Warning	Analog Cal Warning
Rear Board Not Detected	Cannot Dyn Zero
Relay Board Warning	Cannot Dyn Span

¹ Although assigned flags, these units are not available on the T100H



3.7.2.3 HESSEN GAS LIST CONFIGURATION

Configure the Hessen Gas List in the Setup>Comm>Hessen>Hessen Gas List page. Choose the Gas, the concentration Range, and enter the gas ID. Refer to and to the table below.

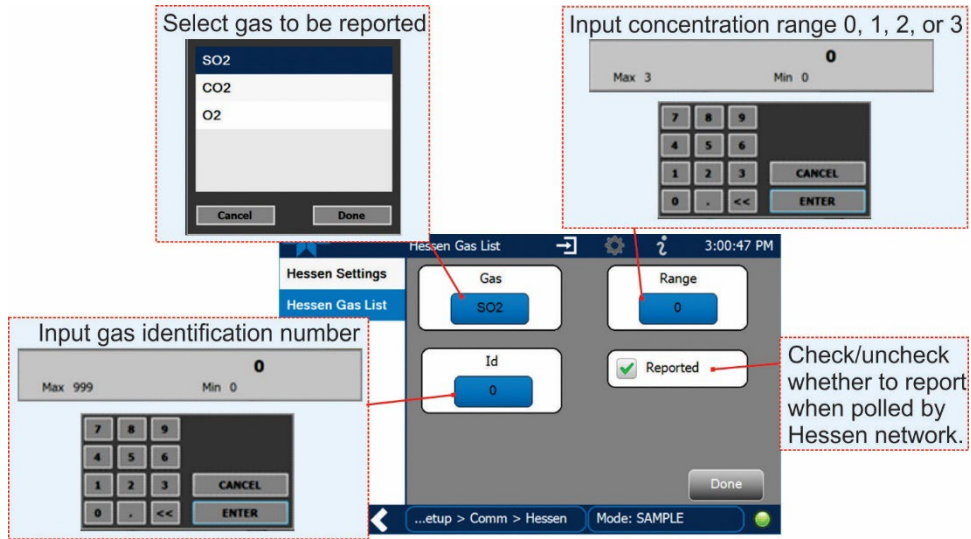

Menu: Setup>Comm>Hessen>Hessen Settings>Hessen Gas List

Figure 3-4. Hessen Gas List Configuration

Table 3-5. Hessen Gas List Definitions

PARAMETER	DEFINITION
Gas	type of gas to be reported
Range	concentration range to be reported (when Reported box is checked)
0	currently active range
1	only when range 1 or low range is active
2	only when range 2 or high range is active
3	Not Applicable
Id	specific gas identification
110	SO ₂
Reported	choice of whether to report when polled by the Hessen network



4 CALIBRATION

This section is organized into subsections as follows:

SECTION 4.4 – Important Precalibration Information

: contains important information you should know before calibrating the instrument.

SECTION 4.5 – Calibration Procedures: describes the procedure for manually checking calibration and performing actual calibration of the instrument.

SECTION 4.6 – Automatic Zero/Span Cal/Check (Auto Cal): describes the procedure for using the AutoCal feature to check calibration or to calibrate the instrument. (The AutoCal feature requires that either the zero/span valve option or the internal span gas generator option be installed and operating).

SECTION 4.7 – Calibration Quality Analysis: describes how to evaluate quality of each calibration.

SECTION 4.8 – EPA Protocol Calibration: provides links to the US EPA website for references regarding calibration with EPA protocols (applies to T100, T100U).

4.4 IMPORTANT PRECALIBRATION INFORMATION

Note

A start-up period of 4-5 hours is recommended prior to calibrating the analyzer.

4.4.1 CALIBRATION REQUIREMENTS

The following equipment, supplies, and expendables are required for calibration:

- Zero-air source
- Span gas source
- Gas lines - all gas line materials should be Teflon-type or glass.
- Traceability Standards

Optional equipment: A recording device such as a strip-chart recorder and/or data logger should be used to record data from the T100's serial or analog outputs. If analog readings are used, the response of the recording system should be checked against a NIST traceable voltage source or meter. Data recording device should be capable of bi-polar operation so that negative readings can be recorded. For electronic documentation, the internal data acquisition system (DAS) can be used by configuring the Datalogger through the Setup>Data Logging menu; Section 2.5.1).



T100, T100U, T100H

The method for performing an initial calibration for the analyzer differs between the standard instrument and those with options.

- See Section 4.5.1 for instructions for initial calibration of the analyzer in its base configuration.
- See Section 4.5.2 for information regarding setup and calibration of the analyzer with Z/S Valve options.

Note

Zero air and span gases must be supplied at 1.5 to 2 times the instrument's specified gas flow rate. Therefore, the zero and span gases should be supplied to their respective inlets in excess of 1000 cc/min.

4.4.2 ZERO AIR

Zero air is similar in chemical composition to the Earth's atmosphere but scrubbed of all components that might affect the analyzer's readings. For SO₂ measuring devices, zero air should be similar in composition to the sample gas but devoid of SO₂ and large amounts of hydrocarbons, nitrogen oxide (NO) and with a water vapor dew point $\leq -15^{\circ}\text{C}$.

Devices such as the API Model 701 zero air generator that condition ambient air by drying and removal of pollutants are available. We recommend this type of device for generating zero air.

4.4.3 CALIBRATION (SPAN) GAS

Span gas is specifically mixed to match the chemical composition of the gas being measured at about 80% of the desired full measurement range. For example, if the measurement range is 500 ppb, the span gas should have an SO₂ concentration of about 400 ppb.

Span gases should be certified to a specific accuracy to ensure accurate calibration of the analyzer. Typical gas accuracy for SO₂ gases is 1 or 2 %.

- If using a secondary dilution source with zero air through a calibrator, then use a bottle of SO₂ balanced nitrogen.
- If calibrator and zero air source are not available, then use a bottle of SO₂ balanced air.

Teledyne API offers an IZS option operating with permeation devices. The accuracy of these devices is about $\pm 5\%$. Whereas this may be sufficient for quick, daily calibration checks, we strongly recommend using certified SO₂ span gases for accurate calibration.



4.4.4 SPAN GAS FOR MULTIPOINT CALIBRATION

Some applications, such as EPA monitoring, require a multipoint calibration procedure where span gases of different concentrations are needed. We recommend using a bottle of calibrated SO₂ gas of higher concentration in conjunction with a gas dilution calibrator such as a Teledyne API Model T700. This type of calibrator precisely mixes a high concentration gas with zero air (both supplied externally) to accurately produce span gas of the correct concentration. Linearity profiles can be automated with this model and run unattended over night.

If a dynamic dilution system is used to dilute high concentration gas standards to low, ambient concentrations, ensure that the SO₂ concentration of the reference gas matches the dilution range of the calibrator.

Choose the SO₂ gas concentration so that the dynamic dilution system operates in its mid-range and not at the extremes of its dilution capabilities.

EXAMPLE:

- A dilution calibrator with 10-10000 dilution ratio will not be able to accurately dilute a 5000 ppm SO₂ gas to a final concentration of 500 ppb, as this would operate at the very extreme dilution setting.
- A 100 ppm SO₂ gas in nitrogen is much more suitable to calibrate the T100 analyzer (dilution ratio of 222, in the mid-range of the system's capabilities).

4.4.5 PHYSICAL RANGE MEASUREMENTS

The entire measurement range of the T100 is 0 – 20,000 ppb, but many applications use only a small part of the analyzer's full measurement range, which then becomes a data resolution challenge where the reported measurement may be barely perceptible. The software rectifies this challenge when the user defines the portion of the physical range relevant to the specific application, which the software then uses to scale the reporting range and accurately display the concentration(s).

To define the physical range for applications requiring greater resolution and sensitivity, navigate to the Setup>Vars menu and select Max Concentration Range; press the edit button and input the maximum value expected for the SO₂ concentrations.



T100, T100U, T100H

4.4.6 INTERFERENTS

The fluorescence method for detecting SO₂ is subject to interference from a number of sources including hydrocarbons, which fluoresce similarly to SO₂. However, the analyzer has been designed to reject most of these interferences.

Nitrogen oxide (NO) also fluoresces in a spectral range near to SO₂. For critical applications where high levels of NO are expected, an optional optical filter is available that improves the rejection of NO (contact Technical Support for more information).

4.4.7 PERMEATION TUBE OPTIONS

Teledyne API offers an optional internal span gas generator that utilizes a permeation tube as a span gas source (see Section 2.3.2.5). The accuracy of these devices is only about ±5%. Whereas this may be sufficient for quick, daily calibration checks, we recommend using certified SO₂ span gases for accurate calibration.

CAUTION!



Insufficient gas flow allows gas to build up to levels that will contaminate the instrument or present a safety hazard to personnel.

In units with a permeation tube installed, either the tube must be removed and stored in a sealed container (use original container that tube was shipped in) during periods of non-operation, or a vacuum pump must be connected and powered on to maintain constant gas flow through the analyzer at all times.

4.4.8 DATA RECORDING DEVICES

A strip chart recorder, data acquisition system or digital data acquisition system should be used to record data from either the Ethernet, serial or analog outputs.

- If analog readings are used, the response of the recording system should be checked against a NIST traceable voltage source or meter.
- Data recording devices should be capable of bi-polar operation so that negative readings can be recorded.

For electronic data recording, the analyzers provide an internal data logger, which is configured through the Setup>Data Logger menu (Section 2.5.1).

NumaView™ Remote is a remote control program, which is also available as a convenient and powerful tool for data handling, download, storage, quick check and plotting.



4.5 CALIBRATION PROCEDURES

This section presents the steps for calibration and calibration checks for the following:

- basic configuration (Section 4.5.1)
- with valve options (Section 4.5.2)
- with IZS option (Section 4.6)
- for dual or auto reporting range modes (Section)
- and for optional sensors (Section).

First verify/change (if needed) the settings in the Setuu>Vars menu as follows:

- User Units (unit of Measure): PPB
- Max Concentration Range (highest concentration expected to measure)
- Range Mode: SNGL

4.5.1 CALIBRATION AND CHECK PROCEDURES FOR BASIC CONFIGURATION

Although this section uses the Calibration menu for both check and actual calibration, a check does not require the Calibration menu. Instead, while in Home page, simply flow the zero air or the span gas through the Sample port, and check the reading after the Stability falls below 1.0 PPB (either in the gas graph or in the Dashboard). Otherwise, follow the steps presented in Sections 4.5.1.1 and 4.5.1.2. after connecting the sources of zero air and span gas in either of the following two ways:



T100, T100U, T100H

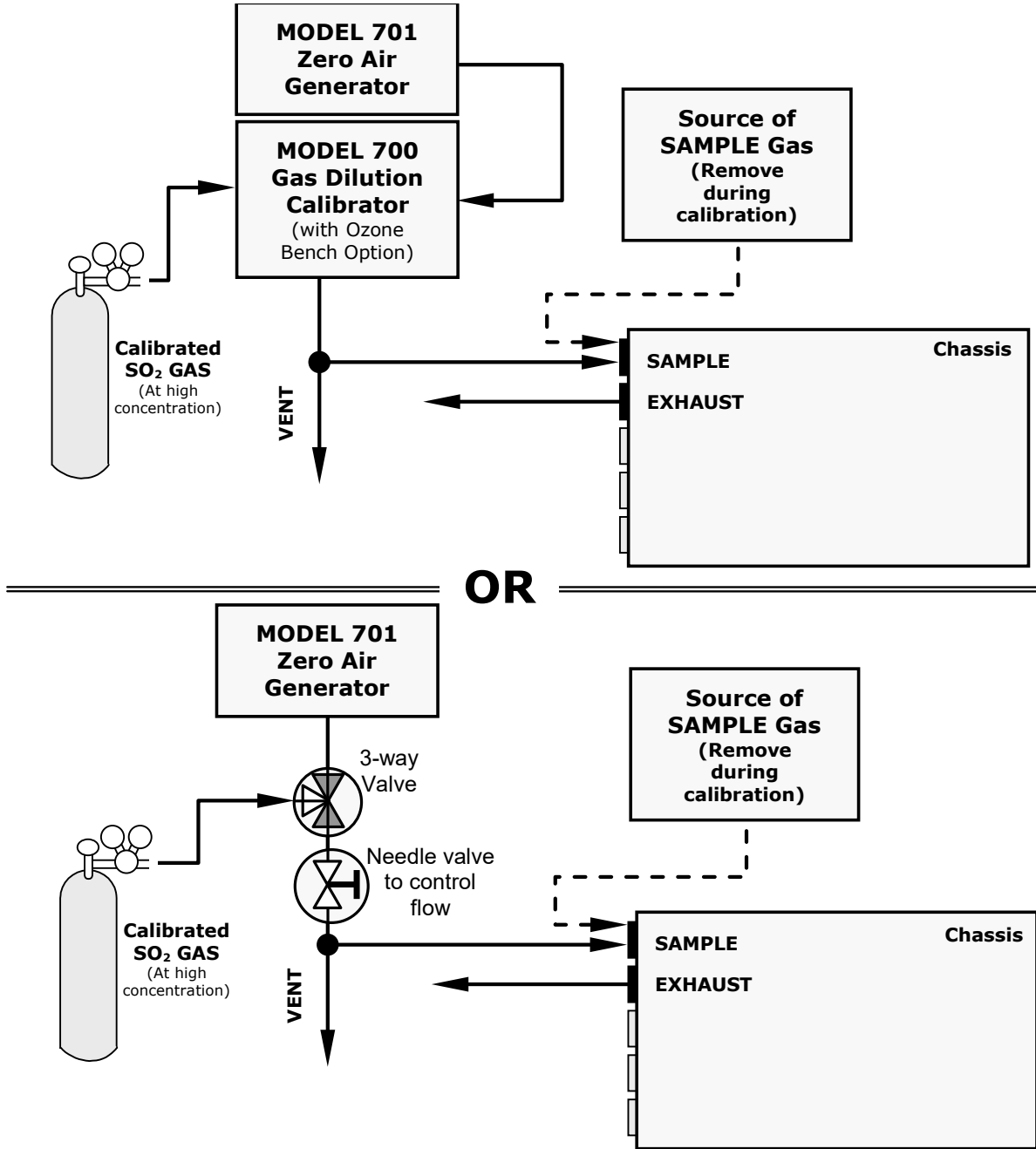

Figure 4-1. Setup for Manual Calibration without Z/S Valve or IZS Option



T100, T100U, T100H

4.5.1.1 ZERO CALIBRATION CHECK AND ACTUAL CALIBRATION

1. Go to the Calibration>M-P menu.
2. Input Zero air through the Sample port and press the Start button.
3. Either check or calibrate as follows:

CHECK ONLY:

- a. Wait for reading to stabilize.
- b. Press Stop and check the reading.

ACTUAL CALIBRATION:

- a. Press the Zero button.
- b. Press Stop and check the reading.

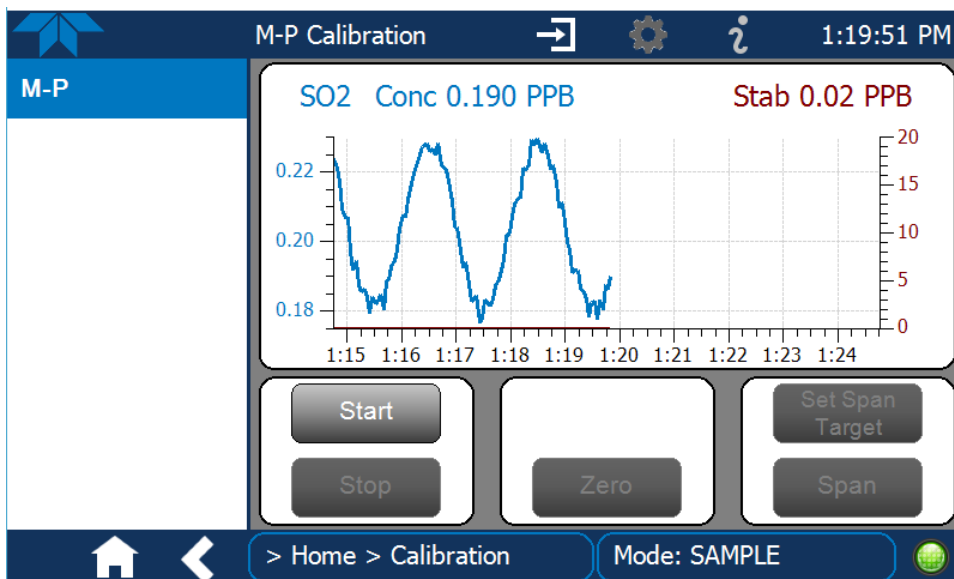

Figure 4-2. Multi-Point Calibration Page

4.5.1.2 SPAN CALIBRATION CHECK AND ACTUAL CALIBRATION

1. While still in the Calibration>M-P menu, input Span gas through the Sample port and press the Start button.
2. Either check or calibrate as follows:

CHECK ONLY:

- a. Wait to reach stability, then press Stop.
- b. Record the reading(s).

ACTUAL CALIBRATION:

- a. Press the Set Span Target button and enter the gas concentration.
 - b. Verify the concentration reading is the same as the concentration being supplied.
 - c. If correct, wait to reach stability, then press the Span button.
 - d. In the Cal Result window, press OK.
3. Press the Stop button and return to Home screen.
 4. In the Dashboard, check and record the Slope(s) and the Offset(s). (See Table 4-4 in Section 4.7 for expected/acceptable values).



4.5.2 CALIBRATION AND CHECK PROCEDURES WITH VALVE OPTIONS INSTALLED

On units with an IZS option installed, zero air and span gas are supplied to the analyzer through the zero gas inlet and from ambient air.

On units with a zero/span valve option installed, zero air and span gas are supplied to the analyzer through the zero gas and span gas inlets from two different sources.

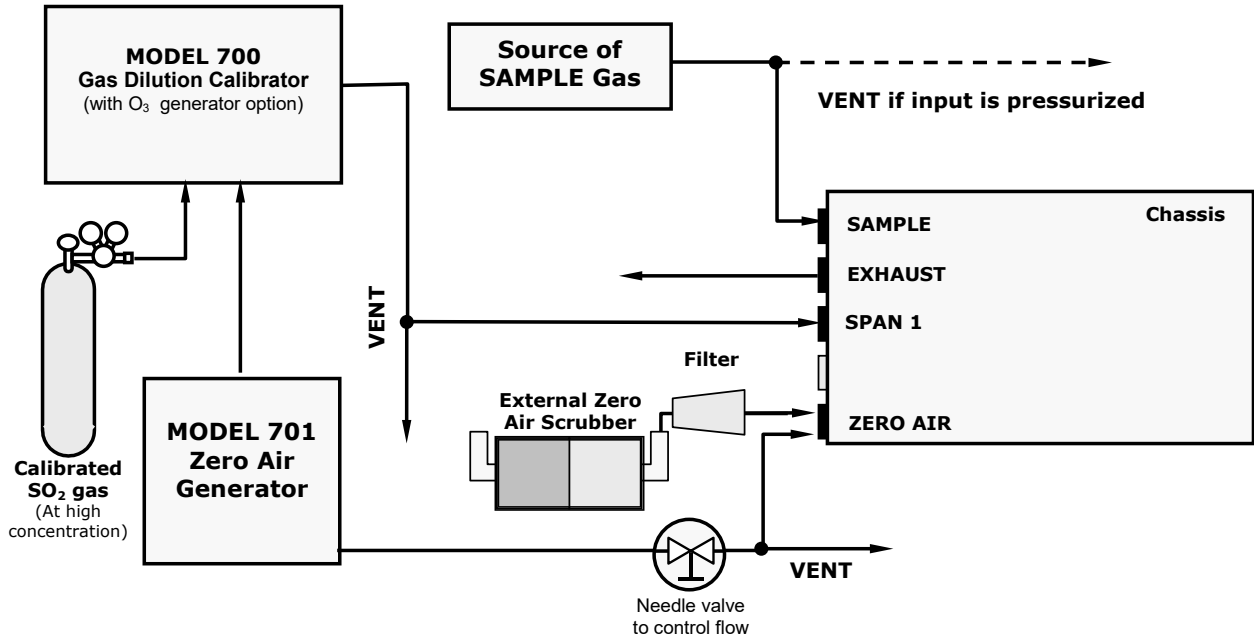

Internal Zero/Span Option (IZS) – Option 51A

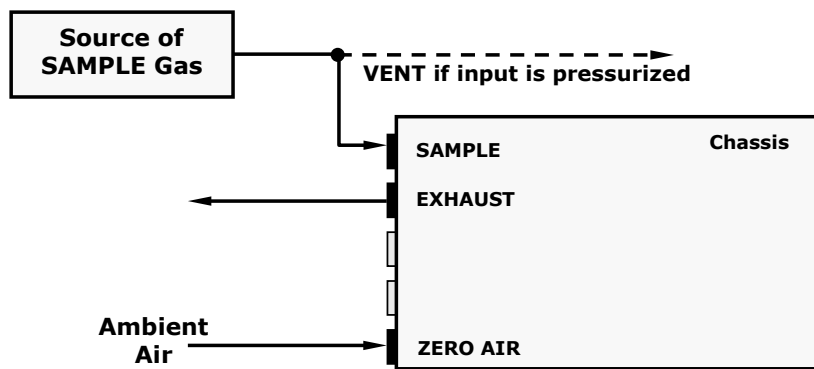

Figure 4-3. Setup for Manual Calibration Check with Z/S Valve or IZS Option

Navigate to the Calibration>Zero menu for Zero cal and to the Calibration>Span menu for Span cal (see Figure 4-4) and follow the instructions in Sections 4.5.1.1 and 4.5.1.2.



Figure 4-4. Zero and Span Calibration Screens

4.5.2.1 USE OF ZERO/SPAN VALVE WITH REMOTE CONTACT CLOSURE

Contact closures for controlling calibration and calibration checks are located on the rear panel CONTROL IN connector. Instructions for setup and use of these contacts are in Section 2.3.1.5.

When the contacts are closed for at least 5 seconds, the instrument switches into zero, low span or high span mode and the internal zero/span valves will be automatically switched to the appropriate configuration.

- The remote calibration contact closures may be activated in any order.
- It is recommended that contact closures remain closed for at least 10 minutes to establish a reliable reading.
- The instrument will stay in the selected mode for as long as the contacts remain closed.

If contact closures are being used in conjunction with the analyzer’s AutoCal (see Section 4.6) feature and the AutoCal attribute “Calibrate” is enabled (selection box is checked), the

analyzer will not recalibrate the analyzer UNTIL the contact is opened. At this point, the new calibration values will be recorded before the instrument returns to SAMPLE mode.

If the AutoCal attribute “Calibrate” is disabled (selection box is unchecked), the instrument will return to SAMPLE mode, leaving the instrument’s internal calibration variables unchanged.

4.6 AUTOMATIC ZERO/SPAN CAL/CHECK (AUTO CAL)

The Auto Cal feature allows unattended periodic operation of the ZERO/SPAN valve options by using the instrument’s internal time of day clock. Auto Cal operates by executing preprogrammed calibrations or calibration checks set up by the user to initiate the various calibration states of the analyzer and to open and close valves appropriately. It is possible to set up and run up to three separate preprogrammed calibrations or calibration checks (labeled # 1, 2 and 3). Each calibration or check can operate in one of three modes (Zero, Low or High), or be disabled.

Table 4-1 and Table 4-2 show how to set up the operating states of each calibration or check, and Table 4-3 shows how to program the execution of each.

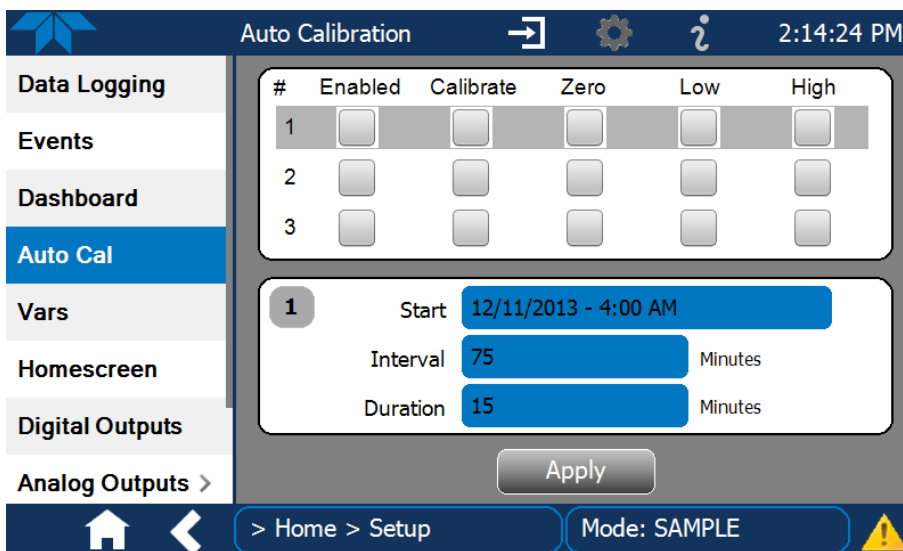

Figure 4-5. Auto Cal Page



T100, T100U, T100H

Table 4-1. Auto Cal States

MODE NAME	ACTION
Enabled	<input checked="" type="checkbox"/> enables the sequence; <input type="checkbox"/> disables the sequence.
Calibrate	<input checked="" type="checkbox"/> enables an actual calibration when the Enabled box is also <input checked="" type="checkbox"/> <input type="checkbox"/> allows a calibration check when the Enabled box is also <input checked="" type="checkbox"/> .
Zero	<input checked="" type="checkbox"/> causes the sequence to perform a Zero calibration when both the Calibrate and Enabled boxes are also <input checked="" type="checkbox"/> <input checked="" type="checkbox"/> causes a Zero check when the Enabled box is also <input checked="" type="checkbox"/> and the Calibrate box is unchecked (<input type="checkbox"/>) <input type="checkbox"/> disables Zero calibration and check
Low	<input checked="" type="checkbox"/> causes the sequence to perform a Low Span calibration when both the Calibrate and Enabled boxes are also <input checked="" type="checkbox"/> <input checked="" type="checkbox"/> causes a Low Span check when the Enabled box is also <input checked="" type="checkbox"/> and the Calibrate box is unchecked (<input type="checkbox"/>) <input type="checkbox"/> disables Low Span calibration and check
High	<input checked="" type="checkbox"/> causes the sequence to perform a High Span concentration calibration when both the Calibrate and Enabled boxes are also <input checked="" type="checkbox"/> <input checked="" type="checkbox"/> causes a High Span check when the Enabled box is also <input checked="" type="checkbox"/> and the Calibrate box is unchecked (<input type="checkbox"/>) <input type="checkbox"/> disables the High Span calibration and check.

Table 4-2 shows how the selection boxes would be enabled/disabled for calibration checks and calibrations.

Table 4-2. Auto Cal Setup Combinations

MODE	ACTION	STATE				
		Enabled	Calibrate	Zero	Low	High
Zero	Check	<input checked="" type="checkbox"/>	<input type="checkbox"/>	<input checked="" type="checkbox"/>	<input type="checkbox"/>	<input type="checkbox"/>
	Calibrate	<input checked="" type="checkbox"/>	<input checked="" type="checkbox"/>	<input checked="" type="checkbox"/>	<input type="checkbox"/>	<input type="checkbox"/>
Low	Check	<input checked="" type="checkbox"/>	<input type="checkbox"/>	<input type="checkbox"/>	<input checked="" type="checkbox"/>	<input type="checkbox"/>
	Calibrate	<input checked="" type="checkbox"/>	<input checked="" type="checkbox"/>	<input type="checkbox"/>	<input checked="" type="checkbox"/>	<input type="checkbox"/>
High	Check	<input checked="" type="checkbox"/>	<input type="checkbox"/>	<input type="checkbox"/>	<input type="checkbox"/>	<input checked="" type="checkbox"/>
	Calibrate	<input checked="" type="checkbox"/>	<input checked="" type="checkbox"/>	<input type="checkbox"/>	<input type="checkbox"/>	<input checked="" type="checkbox"/>
Zero Low High	Check	<input checked="" type="checkbox"/>	<input type="checkbox"/>	<input checked="" type="checkbox"/>	<input checked="" type="checkbox"/>	<input checked="" type="checkbox"/>
	Calibrate	<input checked="" type="checkbox"/>	<input checked="" type="checkbox"/>	<input checked="" type="checkbox"/>	<input checked="" type="checkbox"/>	<input checked="" type="checkbox"/>

For each sequence, there are four parameters that control operational details: Date, Time (both in the Start field), Interval, and Duration, as presented in Table 4-3.



T100, T100U, T100H

Table 4-3. Auto Cal Programming Sequence Execution

ATTRIBUTE	ACTION
Start	When the Enabled box is “on” <input checked="" type="checkbox"/> , the Sequence (identified by its number) begins on the date and time shown in the configurable Start field. (Click the field for the pop-up window and toggle between the Time (Hour/Minutes) and the Date (Year/Month/Day) attributes to edit as needed).
Interval	Number of minutes to skip between each Sequence execution. (Click the field to input the number of minutes in the pop-up window).
Duration	Number of minutes that each Sequence execution is to run. (Click the field to input the number of minutes in the pop-up window).

Important

IMPACT ON READINGS OR DATA

- The programmed STARTING_TIME must be a minimum of 5 minutes later than the real time clock for setting real time clock (Setup>Instrument, Section 2.5.9).
- Avoid setting two or more sequences at the same time of the day.
- Any new sequence that is initiated whether from a timer, the COM ports or the contact closure inputs will override any sequence that is in progress.
- **It is recommended that calibrations be performed using external sources of Zero Air and Span Gas whose accuracy is traceable to EPA standards.**

4.7 CALIBRATION QUALITY ANALYSIS

After completing a calibration procedure, it is important to evaluate the analyzer’s calibration **SLOPE** and **OFFSET** parameters. These values describe the linear response curve of the analyzer. The values for these terms, both individually and relative to each other, indicate the quality of the calibration.

Set up the Data Logger with a Periodic trigger (see Section 2.5.1) to record the values of the SO₂ Norm Offset and SO₂ Slope parameters.

Ensure that these parameters are within the limits listed in Table 4-4 and frequently compare them to those values on the *Final Test and Validation Data Sheet* that came with your instrument, which should not be significantly different. Otherwise, refer to the troubleshooting Section 5.7.6.

Table 4-4. Calibration Data Quality Evaluation

FUNCTION	MINIMUM VALUE	OPTIMUM VALUE	MAXIMUM VALUE
SO ₂ SLOPE	-0.700	1.000	1.300
SO ₂ Norm Offset	50.0 mV	n/a	250.0 mV



4.8 EPA PROTOCOL CALIBRATION

When running this instrument for U.S. EPA compliance, always calibrate prior to use, adhering to the EPA designation requirements for this instrument. (The official List of Designated Reference and Equivalent Methods is published in the U.S. Federal Register: <http://www3.epa.gov/ttn/amtic/criteria.html>; this List specifies the settings and configurations for EPA calibration protocol). Pay strict attention to the built-in warning features, periodic inspection, regular zero/span checks, regular test parameter evaluation for predictive diagnostics and data analysis, and routine maintenance. Any instrument(s) supplying the zero air and span calibration gasses used must themselves be calibrated, and that calibration must be traceable to an EPA/NIST primary standard.

Comply with Code of Federal Regulations, Title 40 (downloadable from the U.S. Government Publishing Office at <http://www.gpo.gov/fdsys/>) and with Quality Assurance Guidance documents (available on the EPA website: <http://www3.epa.gov/ttn/amtic/qalist.html>).

Give special attention to specific regulations regarding the use and operation of ambient sulfur dioxide (fluorescence-based) analyzers.



5 MAINTENANCE AND SERVICE

Follow the maintenance schedule set forth in Section 5.1. Service and troubleshooting are covered in Section 5.7. To support your understanding of the technical details of maintenance and service, the principles of operation in Section 6 provides information about how the instrument works.

ATTENTION

COULD DAMAGE INSTRUMENT AND VOID WARRANTY
Avoid spraying anything directly onto any part of the analyzer.

5.1 MAINTENANCE SCHEDULE

Table 5-1 shows a typical maintenance schedule. The actual frequency of performing these procedures can vary depending on the operating environment. Additionally, in some cases, there are local regulations or standards that also need to be considered.

In certain environments (e.g., dusty, very high ambient pollutant levels) some maintenance procedures may need to be performed more often than shown.



WARNING – ELECTRICAL SHOCK HAZARD

Disconnect power before performing any of the following operations that require entry into the interior of the analyzer.



CAUTION – QUALIFIED PERSONNEL

These maintenance procedures must be performed by qualified technicians only.

Important

IMPACT ON READINGS OR DATA

A span and zero calibration check (see CAL CHECK REQ'D Column of Table 5-1) must be performed following some of the maintenance procedures listed herein. To perform a CHECK of the instrument's Zero or Span Calibration, refer to Sections 4.5.1.1 and 4.5.1.2, respectively.

When running a “check” only, DO NOT press the Zero or Span buttons at the end of each operation (actual calibration), as this will reset the stored values for OFFSET and SLOPE and alter the instrument's calibration.

Alternatively, use the Auto Cal feature described in Section 4.6 with the CALIBRATE attribute set to OFF (not enabled).



T100, T100U, T100H

Table 5-1. Maintenance Schedule

ITEM	ACTION	FREQ	CAL CHECK REQ'D	DATE PERFORMED												
Dashboard functions	Review and evaluate	Weekly	No													
¹ Particulate filter	Change	Weekly or as necessary	No													
Zero/span check	Evaluate offset and slope	Weekly	No													
¹ Zero/span calibration	Calibrate Zero and span	Every 3 months	Yes													
¹ External zero air scrubber option	Exchange chemical	Every 3 months	No													
¹ Flow	Check Flow	Every 6 months	No													
Software/ Firmware	Check for updates	Every 6 months or whenever serviced	Yes													
² Internal IZS Permeation Tube	Replace	Annually	Yes													
Calibrate Lamp Output	Perform Lamp Cal	Prior to zero/span calibration or PMT hardware calibration														
DFU filters	Change	Annually (or as needed for highly polluted sample air)	No													
Pneumatic sub-system	Check for leaks in gas flow paths	Annually or after repairs involving pneumatics	Yes if a leak is repaired													
¹ Sample chamber optics	Clean chamber, windows & filters	As necessary	Yes													
¹ PMT Sensor Hardware Calibration	Low-level hardware calibration	When PMT/ preamp changes or if slope is outside of 0.7 – 1.3	Yes													
Pump	Rebuild head	when Rx Cell pressure exceeds 10 in-Hg-A (at sea level)	Yes													
¹ Pump Diaphragm	Replace	Annually	Yes													
¹ Critical flow orifice & sintered filters	Replace	As necessary	Yes													
Desiccant bags	Replace	Any time PMT housing is opened for maintenance	n/a													

¹ These Items are required to maintain full warranty; all other items are strongly recommended.

² There is no IZS in the T100H



5.2 PREDICTIVE DIAGNOSTICS

Predictive diagnostic functions, including failure warnings and alarms built into the analyzer’s firmware, aid in determining whether and when repairs are necessary.

Dashboard Functions can also be used to predict failures by looking at how their values change over time, compared to the values recorded on the printed record of the *Final Test and Validation Data Sheet*. The internal data logger is a convenient way to record and track these changes (set up through the Data Logger, Section 2.5.1). Use NumaView™ Remote to download and review this data from a remote location.

The following table, checked weekly, can be used as a basis for taking action as these values change with time.

Table 5-2. Predictive Uses for Dashboard Functions

FUNCTION	EXPECTED	ACTUAL	INTERPRETATION
Dark PMT (PMT output when UV lamp shutter closed)	Constant to within ± 20 of check-out value	Significantly increasing	<ul style="list-style-type: none"> • PMT cooler failure • Shutter Failure
Lamp Ratio	Stable and near 100%	Fluctuating or Slowly increasing	<ul style="list-style-type: none"> • UV detector wearing out • UV source Filter developing pin holes
		Slowly decreasing	<ul style="list-style-type: none"> • UV detector wearing out • Opaque oxides building up on UV source Filter • UV lamp aging
Pressure	Constant within atmospheric changes	Fluctuating	Developing leak in pneumatic system. Check for leaks.
		Slowly increasing	Flow path is clogging up. Check and/or replace orifice filters. Replace particulate filter
		Slowly decreasing	Developing leak in pneumatic system to vacuum (developing valve failure). Check for leaks.
Sample Flow	Stable	Slowly decreasing	Flow path is clogging up. Check and/or replace orifice filters. Replace particulate filter
		Fluctuating	Leak in gas flow path.
SO ₂ Conc (Concentration)	(At span with IZS option installed): Constant response from day to day.	Decreasing over time	Change in instrument response
			Degradation of IZS permeation tube
	(Standard configuration at span): Stable for constant concentration	Decreasing over time	Drift of instrument response; UV Lamp output is excessively low.
			T100H: Fluctuating
Vacuum Press (T100H)	Constant within atmospheric changes	Fluctuating	Developing leak in pneumatic system



5.3 OPERATIONAL HEALTH CHECKS

Navigate to the Utilities>USB Utilities>Report menu (Figure 5-1) to download a report on the basic operations of the instrument. The report is generated every 24 hours to a Web services “cloud” where it is available for viewing by Teledyne API technical support personnel. To download the report for your own viewing on a computer or to send to others, insert a flash drive into a front panel USB port and press the Download button, which is enabled when the instrument detects the flash drive.

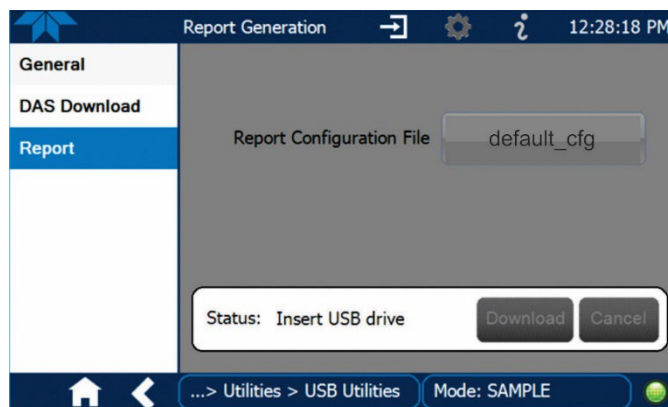

Figure 5-1. Report Generation Page

5.4 SOFTWARE/FIRMWARE UPDATES

An automatic weekly check for updates can be enabled in the Setup>Vars>Periodically Check for Updates menu, and/or a check for updates can be prompted at any time in the Setup>Instrument>Remote Update page. Downloading updates can be performed either remotely (5.4.1) or manually (5.4.2).

5.4.1 REMOTE UPDATES

The instrument must be connected to a network that is connected to the Internet. In the Setup>Instrument menu, select the Remote Update menu and press the Check for Updates button (Figure 5-2). If an update is available, the Update button will be enabled.

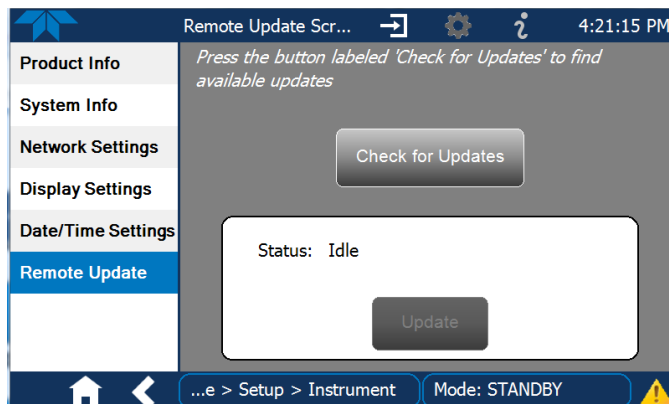

Figure 5-2. Remote Update Page



5.4.2 MANUAL RELOAD/UPDATE PROCEDURES

To reload or update firmware, first contact Technical Support to obtain the applicable file(s): api-techsupport@teledyne.com / 800-324-5190.

1. Follow Technical Support's instructions for copying the firmware files to a flash drive.
2. Go to the Utilities>USB Utilities>General menu.

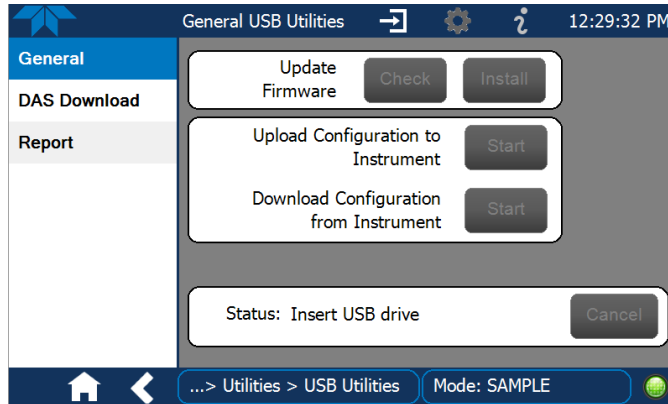

Figure 5-3. Manual Update Page (and other utilities)

3. Insert a flash drive into a front panel USB port and wait for the Status field to indicate that the drive has been detected.
4. In the Update Firmware field, press the Check button for the instrument to determine whether the firmware on the flash drive is more recent than what is currently installed. Once it's been determined that the firmware is new, the Install button will be enabled; if the firmware version on the flash drive is the same as or older than the current firmware of the instrument, the Install button will not be enabled.
5. Press the Install button, and note the messages in the Status field at the bottom of the page. Use the Cancel button if necessary.
6. When complete, as indicated in the Status field, press the Done button, which replaces the Cancel button, and remove the flash drive.
7. Power off and restart the instrument to complete the new firmware installation.



5.4.3 TOUCHSCREEN DISPLAY CALIBRATION (FOR EARLIER INSTRUMENTS)

This section applies to instruments shipped before January 2017. Although unlikely, if ever the touchscreen appears unresponsive or responds incorrectly, the screen can be calibrated via the Setup>Instrument>Display Settings menu.

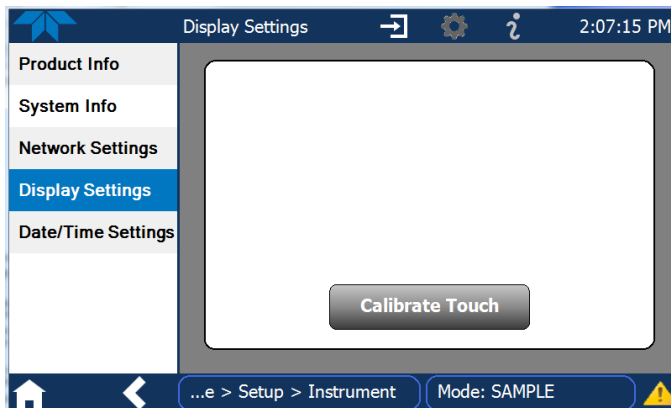

Figure 5-4. Touchscreen Calibration Page

1. Connect a mouse to either of the front panel USB ports.
2. Navigate with the pointer to Setup>Instrument>Display Settings.
3. Click on "Calibrate Touch" and a crosshair appears in the center of the display screen.
4. Note that a timer function is enabled, allowing only 15 seconds to start the calibration process. If the timer expires, the instrument will exit the calibration screen and return to normal operation.
5. Click the very center of the crosshair.
6. When a new crosshair appears in the upper left corner of the screen, carefully and accurately click and hold the very center of that crosshair until it finishes shrinking, then release.
7. Repeat Step 6 for each of the corners.
8. Once the process is completed, a CANCEL and an ACCEPT button appear in the lower left corner: Test the accuracy of the calibration by touching parts of the screen and see that the mouse pointer follows your touches.
9. If you press the CANCEL button, the calibration won't be altered. Otherwise, press the ACCEPT button.

5.5 TIME ZONE CHANGES

There is an option to change between 12-hour and 24-hour format in the Setup>Vars menu (System Time Format). Effectively changing the Time Zone requires a specific procedure as follows:

1. In Setup>Instrument>Date/Time Settings select the applicable Time Zone.
2. Allow adequate time for the selected Time Zone to be properly accepted.
3. Verify: return to Home page then back to the Date/Time Settings page, and check that the selected Time Zone is now highlighted.
4. Without making any other changes, power OFF the instrument and power ON again.
5. Once restarted, return to the Date/Time Settings page where the newly selected Time Zone should be highlighted. (If not, it means that not enough time had passed for the instrument to accept the change before the power was cycled OFF).
6. After the Time Zone is implemented first (Steps 1 through 5), then other changes to the date and/or time can be made, and recycling the power is not necessary.

- ① Time zone change must be set **first**.
- ② **Wait**. Allow sufficient time to accept new Time Zone.
- ③ **Verify**. Return to Home page, then return to Date/Time Settings page.
- ④ After correct Time Zone is displayed, **power recycle** the instrument.
- ⑤ Only after Time Zone is selected and instrument rebooted, can other changes to date and/or time be made effectively.

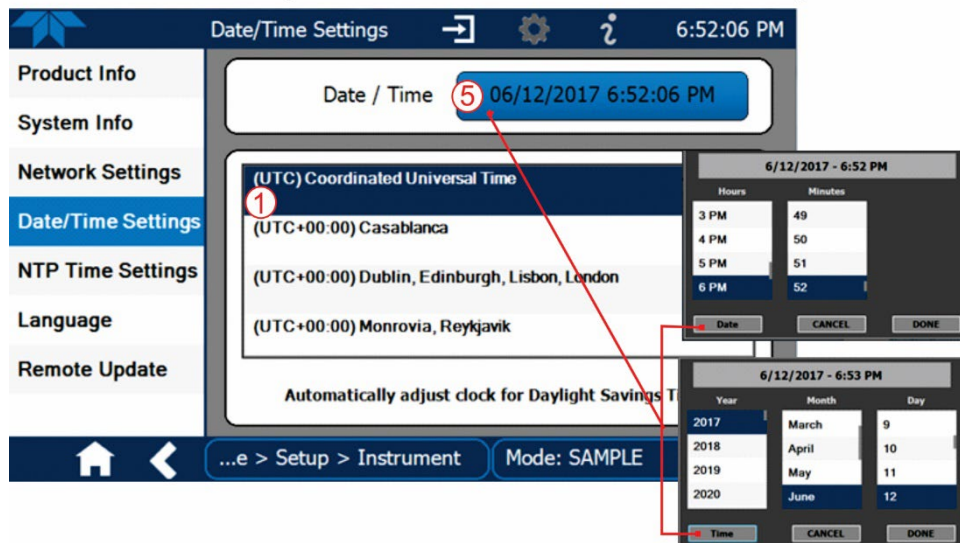

Changes to date and/or time do **not** require a reboot.

Figure 5-5. Time Zone Change Requirements



5.6 HARDWARE MAINTENANCE PROCEDURES

Perform the following procedures as standard maintenance per Table 5-1.

5.6.1 REPLACING THE SAMPLE PARTICULATE FILTER

Note that the T100 uses a 5-micron filter and the T100U uses a 1-micron filter; please call Technical Support for the correct part number. Inspect the particulate filter often for signs of plugging or contamination. It should be replaced according to the service interval schedule even without obvious signs of dirt, as filters with 1 and 5 μm pore size can clog up while retaining a clean look.

Important

IMPACT ON READINGS OR DATA

Use gloves or PTFE coated tweezers or similar handling to avoid contamination of the sample filter assembly. Do not touch any part of the housing, filter element, PTFE retaining ring, glass cover and the o-ring with bare hands, as contamination can negatively impact accuracy of readings.

To change the filter:

1. Turn OFF the analyzer to prevent drawing debris into the instrument.
2. Open the hinged front panel and unscrew the retaining ring on the filter assembly.

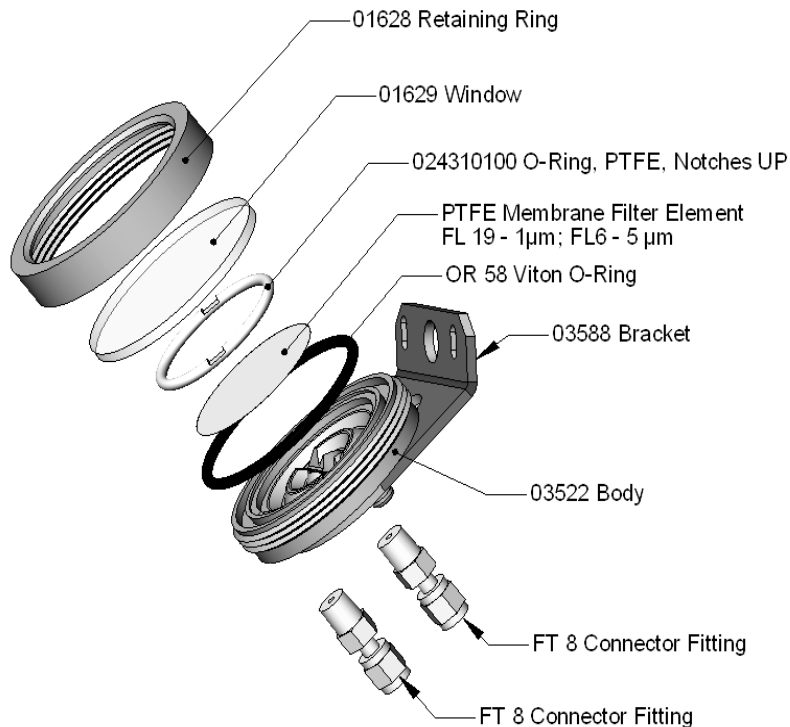

Figure 5-6. Replacing the Particulate Filter

3. Carefully remove the retaining ring, PTFE o-ring, glass window and filter element.



T100, T100U, T100H

4. Replace the filter, being careful that the element is fully seated and centered in the bottom of the holder.
5. Reinstall the PTFE o-ring with the notches up; the glass window, then screw on the retaining ring and hand tighten. Inspect the seal between the edge of filter and the o-ring to assure a proper seal.
6. Close the panel and restart the analyzer.

5.6.2 CHANGING/REMOVING THE IZS PERMEATION TUBE

1. Turn off the analyzer, unplug the power cord and remove the cover.
2. Locate the IZS oven in the rear left of the analyzer.
3. Remove the top layer of insulation if necessary.
4. Unscrew the black aluminum cover of the IZS oven (3 screws) using a medium Phillips-head screw driver.
 - Leave the fittings and tubing connected to the cover.
5. Remove the old permeation tube and replace it with the new tube (or store the permeation tube in its original container if the instrument will not be operated for several or more hours).
 - Ensure that the tube is placed into the larger of two holes and that the open permeation end of the tube (Teflon) is facing up.
6. With the sealing O-ring properly in place, re-attach the cover with three screws.
 - Ensure that the three screws are tightened evenly.
7. Replace the analyzer cover, plug the power cord back in and turn on the analyzer.
8. Carry out an IZS span check to verify that the new permeation device works properly (see Section 4.6).
 - The permeation rate may need several days to stabilize.

ATTENTION

COULD DAMAGE INSTRUMENT AND VOID WARRANTY

Do not leave instrument turned off for more than 8 hours without removing the permeation tube. Do not ship the instrument without removing the permeation tube. The tube continues to emit gas, even at room temperature and will contaminate the entire instrument.



5.6.3 CHANGING THE EXTERNAL ZERO AIR SCRUBBER

The chemicals in the external scrubber need to be replaced periodically according to the maintenance schedule or more frequently as needed. This procedure can be carried out while the instrument is running. Ensure that the analyzer is not in either the ZERO or SPAN calibration modes.

1. Locate the scrubber on the outside rear panel.
2. Remove the old scrubber by disconnecting the 1/4" plastic tubing from the particle filter using 9/16" and 1/2" wrenches.
3. Remove the particle filter from the cartridge using 9/16" wrenches.
4. Unscrew the top of the scrubber canister and discard charcoal contents. Ensure to abide by local laws for discarding these chemicals. The rebuild kit (listed in Appendix B) comes with a Material and Safety Data Sheet, which contains more information on these chemicals.
5. Refill the scrubber with charcoal at the bottom.
6. Tighten the cap on the scrubber - hand-tight only.
7. Replace the DFU filter, if required, with a new unit and discard the old.
8. Replace the scrubber assembly into its clips on the rear panel.
9. Reconnect the plastic tubing to the fitting of the particle filter.
10. Adjust the scrubber cartridge such that it does not protrude above or below the analyzer in case the instrument is mounted in a rack. If necessary, squeeze the clips for a tighter grip on the cartridge.



5.6.4 SERVICING CRITICAL FLOW ORIFICES

A critical flow orifice, located on the exhaust manifold maintains the proper flow rate of gas through the analyzer. Despite the fact that these flow restrictors are protected by sintered stainless steel filters, they can, on occasion, clog up, particularly if the instrument is operated without a sample filter or in an environment with very fine, sub-micron particle-size dust.

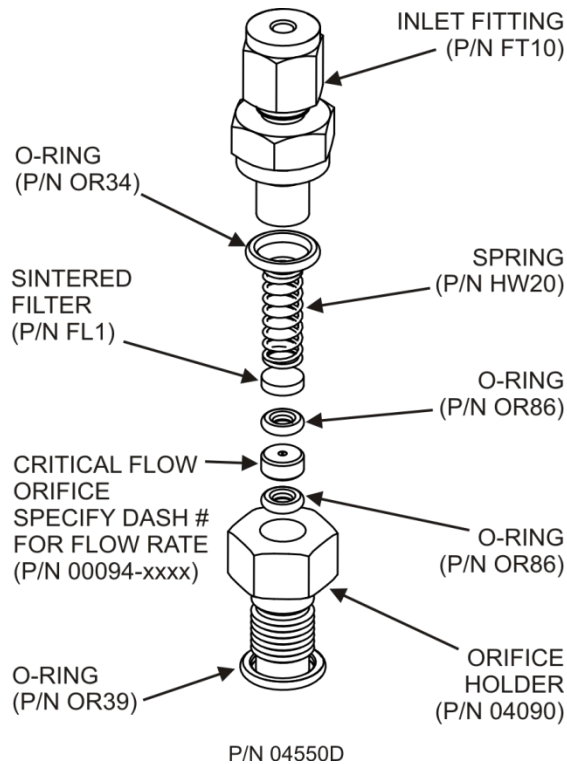

Figure 5-7. Critical Flow Orifice Assembly

To clean or replace a critical flow orifice:

1. Turn off power to the instrument and vacuum pump.
2. Locate the critical flow orifice on the pressure sensor assembly.
3. Disconnect the pneumatic line.
4. Unscrew the NPT fitting.

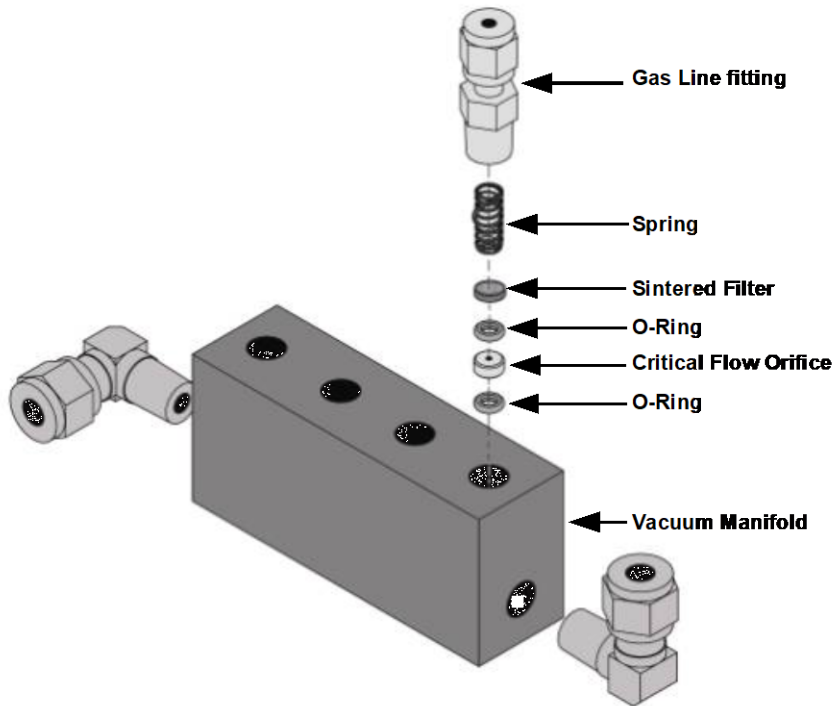

Figure 5-8. Critical Flow Orifice and Vacuum Manifold Assembly

5. Take out the components of the assembly: a spring, a sintered filter, two O-rings and the critical flow orifice.

Note

You may need to use a scribe or pressure from the vacuum port to get the parts out of the manifold.

6. Discard the two O-rings and the sintered filter.
7. Replace the critical flow orifice and let the part dry.
8. Using a new filter and o-rings, reassemble the parts as shown in Figure 5-7.
9. Reinstall the NPT fitting and connect all tubing
10. Power up the analyzer and allow it to warm up for 60 minutes.
11. Perform a leak check.



5.6.5 CHECKING FOR LIGHT LEAKS

When re-assembled after maintenance or repair, or if operated improperly, the PMT assembly can develop small gaps, allowing stray light from the analyzer surroundings into the PMT housing. To find such light leaks, follow the procedures below.



CAUTION – QUALIFIED PERSONNEL ONLY

This procedure is carried out with the analyzer running and its cover removed.

1. In the Dashboard view the **PMT Signal** (if not visible, configure the Dashboard to add; see Section 2.5.3).
2. Supply zero gas to the analyzer.
3. With the instrument still running, carefully remove the analyzer cover.



WARNING – ELECTRICAL SHOCK HAZARD

Do NOT touch any of the inside wiring with the metal cover or with your body.

Do NOT drop screws or tools into a running analyzer.

4. Shine a powerful flashlight or portable incandescent light at the inlet and outlet fittings and at all of the joints of the reaction cell as well as around the PMT housing.
 - The PMT value should not respond to the light; the PMT signal should remain steady within its usual noise performance.
5. If there is a PMT response to the external light, symmetrically tighten the sample chamber mounting screws or replace the 1/4" vacuum tubing with new, black PTFE tubing (this tubing will fade with time and become transparent).

Note

Often, light leaks are also caused by O-rings being left out of the assembly.

6. If, during this procedure, the black PMT housing end plate for the Sensor Assembly is removed, ensure to replace the 5 desiccant bags inside the housing.
7. Carefully replace the analyzer cover. If tubing was changed, carry out a pneumatic leak check (Section 5.6.6).



5.6.6 CHECKING FOR PNEUMATIC LEAKS

This section covers a simple leak check and a detailed leak check.



CAUTION - TECHNICAL INFORMATION

Do not exceed 15 psi when pressurizing the system during either Simple or Detailed checks.

5.6.6.1 SIMPLE VACUUM LEAK AND PUMP CHECK

Leaks are the most common cause of analyzer malfunction. This section presents a simple leak check, whereas the next section details a more thorough procedure. The method described here is easy, fast and detects, but does not locate, most leaks. It also verifies the sample pump condition.

1. If not already running, turn the analyzer ON, and allow at least 30 minutes for flows to stabilize.
2. Cap the sample inlet port (cap must be wrench-tight).
3. After several minutes, when the pressures have stabilized, note the Sample Pressure reading.
 - If equal to within 10% and less than 10 in-Hg-A, the instrument is free of large leaks.
 - It is still possible that the instrument has minor leaks.
 - If the reading greater than 10 in-Hg-A, the pump is in good condition.
 - A new pump will create a pressure reading of about 4 in-Hg-A (at sea level).
4. When finished, switch off the pump and open the cap to the sample inlet port slowly to minimize inrush flow.

5.6.6.2 DETAILED PRESSURE LEAK CHECK

Obtain a leak checker that contains a small pump, shut-off valve, and pressure gauge to create both over-pressure and vacuum. Alternatively, a tank of pressurized gas, with the two-stage regulator adjusted to ≤ 15 psi, a shutoff valve and a pressure gauge may be used.

ATTENTION

COULD DAMAGE INSTRUMENT AND VOID WARRANTY

Once tube fittings have been wetted with soap solution under a pressurized system, do not apply or reapply vacuum as this will cause soap solution to be sucked into the instrument, contaminating inside surfaces.

Also, do not exceed 15 psi when pressurizing the system.

1. Turn OFF power to the instrument and remove the instrument cover.
2. Install a leak checker or a tank of gas (compressed, oil-free air or nitrogen) as described above on the sample inlet at the rear panel.
3. Pressurize the instrument with the leak checker or tank gas, allowing enough time to fully pressurize the instrument through the critical flow orifice.



T100, T100U, T100H

4. Check each tube connection (fittings, hose clamps) with soap bubble solution, looking for fine bubbles.
 - Once the fittings have been wetted with soap solution, do not reapply vacuum as it will draw soap solution into the instrument and contaminate it.
 - Do not exceed 15 psi pressure.
5. If the instrument has the zero and span valve option, the normally closed ports on each valve should also be separately checked.
 - Connect the leak checker to the normally closed ports and check with soap bubble solution.
6. If the analyzer is equipped with an IZS Option, connect the leak checker to the Dry Air inlet and check with soap bubble solution.
7. Once the leak has been located and repaired, the leak-down rate of the indicated pressure should be less than 1 in-Hg-A (0.4 psi) in 5 minutes after the pressure is turned off.
8. Clean surfaces from soap solution, reconnect the sample and pump lines and replace the instrument cover.
9. Restart the analyzer.

5.6.6.3 PERFORMING FLOW CHECKS/CALIBRATIONS

Important

IMPACT ON READINGS OR DATA

For accurate measurements use a separate, calibrated, volumetric flow meter capable of measuring the instrument's flow specifications. Do not use the built in flow measurement viewable in the Dashboard as this value is only calculated, not measured.

The sample gas flow rate through the analyzer is a key part of the gas concentration reading, but the reading is only a calculated value derived by the CPU. The Flow Cal feature under the Utilities>Diagnostics menu is used to check and to calibrate/adjust the calculations.

Sample flow checks, using an external flow meter, are useful for monitoring the actual flow of the instrument to detect drift of the internal flow measurement. A decreasing, actual sample flow may point to slowly clogging pneumatic paths, most likely critical flow orifices or sintered filters (Section 5.6.4).

FLOW CHECK

Low flows indicate blockage somewhere in the pneumatic pathway.

To check the Sample flow with the external flow meter:

1. Disconnect the sample inlet tubing from the rear panel SAMPLE port.
2. Attach the outlet port of a suitable flow meter to the rear panel SAMPLE port.
 - Ensure that the inlet to the flow meter is at atmospheric pressure.
3. The sample flow measured with the external flow meter should be within $\pm 10\%$ of the analyzer's Flow specification (Table 1-1).

FLOW CALIBRATION

To calibrate the Sample flow (Flow Cal):

1. In the Utilities>Diagnostics>Flow Cal menu (Figure 5-9), edit the Actual Flow value by inputting the reading from the external flow meter obtained in the corresponding check of the flow to be calibrated.
2. Press the Calibrate button.

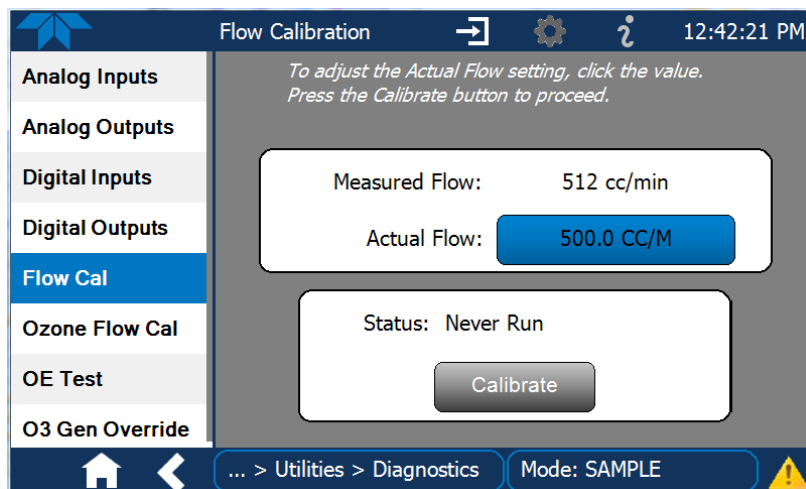

Figure 5-9. Flow Calibration Menu

5.6.7 CHECKING THE HYDROCARBON SCRUBBER (*KICKER*)

There are two possible types of problems that can occur with the scrubber: pneumatic leaks and contamination that ruins the inner tube's ability to absorb hydrocarbons.

5.6.7.1 CHECKING THE SCRUBBER FOR LEAKS

Leaks in the outer tubing of the scrubber can be found using the procedure described in Section 5.6.6.2. Use the following method to determine if a leak exists in the inner tubing of the scrubber.

This procedure requires a pressurized source of air (chemical composition is unimportant) capable of supplying up to 15 psiA and a leak checking fixture such as the one illustrated in Figure 5-10.

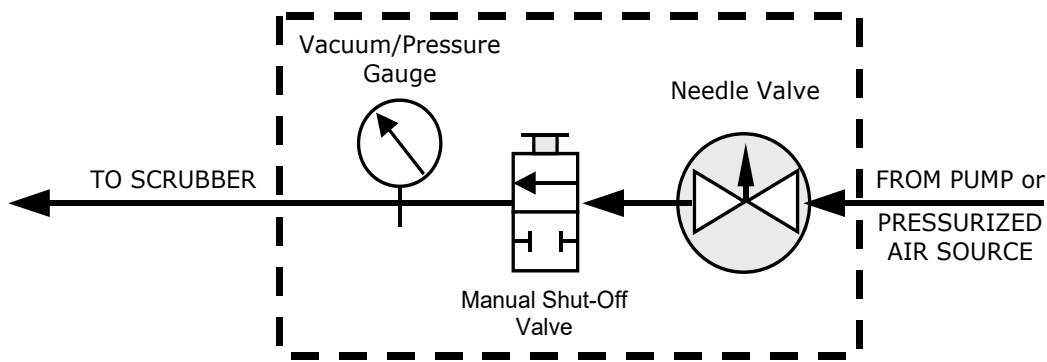

Figure 5-10. Simple Leak Check Fixture



T100, T100U, T100H

1. Turn off the analyzer.
2. Disconnect the pneumatic tubing attached to both ends of the scrubber's inner tubing.
3. One end is connected to the sample particulate filter assembly and the other end is connected to the reaction cell assembly.
4. Both ends are made of the 1/8" black Teflon tubing.
5. Cap one end of the hydrocarbon scrubber.
6. Attach the pressurized air source to the other end of the scrubber inner tubing with the leak check fixture in line.

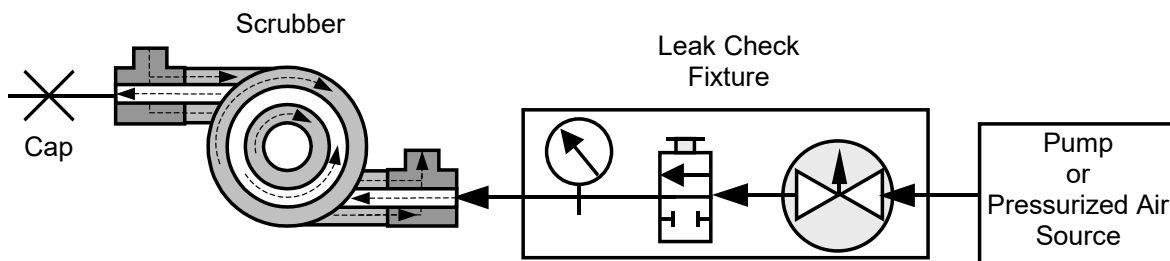

Figure 5-11. Hydrocarbon Scrubber Leak Check Setup

7. Use the needle valve to adjust the air input until the gauge reads 15 psiA.

ATTENTION

COULD DAMAGE INSTRUMENT AND VOID WARRANTY
Ensure the pressure does not exceed 15 psia.
Do not pull vacuum through the scrubber.

8. Close the shut-off valve.
9. Wait 5 minutes.

If the gauge pressure drops >1 psi within 5 minutes, then the hydrocarbon scrubber has an internal leak and must be replaced. Contact Teledyne API's Technical Support.

5.7 SERVICE AND TROUBLESHOOTING

This section contains methods to identify the source of performance problems with the analyzer and procedures to service the instrument.

Note

Section 6, Principles of Operation, provides information about how the instrument works, to support your understanding of the technical details of maintenance.



CAUTION

The operations outlined in this section must be performed by qualified maintenance personnel only.



WARNING – RISK OF ELECTRICAL SHOCK

Some operations need to be carried out with the analyzer open and running.



Exercise caution to avoid electrical shocks and electrostatic or mechanical damage to the analyzer.

Do not drop tools into the analyzer or leave them after your procedures.

Do not short or touch electric connections with metallic tools while operating inside the analyzer.

Use common sense when operating inside a running analyzer.

The analyzer has been designed so that problems can be rapidly detected, evaluated and repaired. During operation, it continuously performs diagnostic tests and provides the ability to evaluate its key operating parameters without disturbing monitoring operations.

A systematic approach to troubleshooting will generally consist of the following five steps:

1. Note any Alerts and take corrective action as necessary (see Table 5-3).
2. Examine the values of all basic functions in the Dashboard and compare them to factory values. Note any major deviations from the factory values and take corrective action.
3. Use the internal electronic status LEDs to determine whether the electronic communication channels are operating properly.
 - Verify that the DC power supplies are operating properly by checking the voltage test points on the relay PCA.
 - Note that the analyzer's DC power wiring is color-coded and these colors match the color of the corresponding test points on the relay PCA.
4. Suspect a leak first!
 - Customer service data indicate that the majority of all problems are eventually traced to leaks in the internal pneumatics of the analyzer or the diluent gas and source gases delivery systems.
 - Check for gas flow problems such as clogged or blocked internal/external gas lines, damaged seals, punctured gas lines, damaged / malfunctioning pumps, etc.
5. Follow the procedures defined in Section 2.3.4.3 to confirm that the analyzer's vital functions are working (power supplies, CPU, relay PCA, PMT cooler, etc.).

5.7.1 FAULT DIAGNOSIS WITH ALERTS

Table 5-3 lists brief descriptions of warning Alerts that may occur during start up and describes their possible causes for diagnosis and troubleshooting.

Note that if more than two or three warning Alerts occur at the same time, it is often an indication that some fundamental sub-system (power supply, relay PCA, motherboard) has failed rather than an indication of the specific failures referenced by the warnings.



T100, T100U, T100H

Table 5-3. Warning Alerts, Fault Conditions and Possible Causes

WARNING	FAULT CONDITION	POSSIBLE CAUSES
ANALOG CAL WARNING	The instrument's A/D circuitry or one of its analog outputs is not calibrated	<ul style="list-style-type: none"> • A parameter for one of the analog outputs, even one not currently being used, has been changed and the analog output calibration routine was not re-run • A/D circuitry failure on motherboard • Other motherboard electronic failure
BOX TEMP WARNING	Temperature of chassis is outside specified limits. (typically < 7°C or > 48°C)	<ul style="list-style-type: none"> • Box Temperature typically runs ~7°C warmer than ambient temperature • Poor/blocked ventilation to the analyzer • Stopped Exhaust Fan • Ambient Temperature outside of specified range
CANNOT DYN SPAN ¹	Dynamic Span operation failed. (Contact closure span calibration failed while the <i>Dynamic Span Var</i> was set to <i>Enabled</i>).	<ul style="list-style-type: none"> • Measured concentration value is too high or low • Concentration Slope value to high or too low
CANNOT DYN ZERO ²	Dynamic Zero operation failed. (Contact closure zero calibration failed while the <i>Dynamic Zero Var</i> was set to <i>Enabled</i>).	<ul style="list-style-type: none"> • Measured concentration value is too high • Concentration Offset value to high
CONFIG INITIALIZED	Configuration and Calibration data reset to original Factory state or erased.	<ul style="list-style-type: none"> • Failed Disk on Module • User erased data
DARK CAL WARNING	Dark Cal signal is too high Dark offset above limit specified indicating that too much stray light is present in the sample chamber.	<ul style="list-style-type: none"> • Light leak in reaction cell • Shutter solenoid is not functioning • Failed relay board • I²C bus failure • Loose connector/wiring • PMT preamp board bad or out of cal
DATA INITIALIZED	Data Storage in DAS was erased before the last power up occurred.	<ul style="list-style-type: none"> • Failed Disk-on-Module • User cleared data.
HVPS WARNING	High voltage power supply output is too high or too low for proper operation of the PMT. (Outside of allowable limits).	<ul style="list-style-type: none"> • High voltage power supply is bad • High voltage power supply is out of cal • A/D converter circuitry is bad
IZS TEMP WARNING ³	On units with IZS options installed: Permeation tube temperature is outside specified limits.	<ul style="list-style-type: none"> • Bad IZS heater • Bad IZS temperature sensor • Bad relay controlling the IZS heater • Entire relay board is malfunctioning • I²C bus malfunction • Failure of thermistor interface circuitry on motherboard



T100, T100U, T100H

WARNING	FAULT CONDITION	POSSIBLE CAUSES
PMT TEMP WARNING	PMT temperature outside of warning limits.	<ul style="list-style-type: none">PMT fan not operatingFailed PMT Temperature SensorFailed PMT TECFailed PMT TEC driver circuitFailed PMT Preamp PCALoose wiring between PMT temperature sensor and PMT Preamp boardMalfunction of analog sensor input circuitry on motherboard
PMT DET WARNING	PMT detector output is outside of operational limits.	<ul style="list-style-type: none">Failed PMTMalfunctioning PMT preamp boardA/D converter circuitry failure
RCELL TEMP WARN	Sample chamber temperature is out of range.	<ul style="list-style-type: none">Failed reaction cell heaterFailed reaction cell temperature sensorMalfunctioning relay controlling the reaction cell heaterEntire relay board malfunctioningI²C bus malfunctioningHeater configured for wrong voltage type
REAR BOARD NOT DET	Motherboard not detected on power up. (CPU unable to communicate with motherboard).	This warning only appears on Serial I/O COM Port(s). Front panel display will be frozen, blank or will not respond. Failure of motherboard
RELAY BOARD WARN	The CPU unable to communicate with the Relay PCA.	<ul style="list-style-type: none">I²C Bus failureFailed Relay BoardLoose connectors/wiring



T100, T100U, T100H

WARNING	FAULT CONDITION	POSSIBLE CAUSES
SAMPLE FLOW WARN	The flow rate of the sample gas is outside the specified limits.	<ul style="list-style-type: none"> Failed Sample Pump Blocked Sample Inlet/Gas Line Dirty Particulate Filter Leak downstream of Critical Flow Orifice Failed flow sensor circuitry
SAMPLE PRES WARN	<p>Sample Pressure is <10 in-Hg or > 35 in-H</p> <p>Note: Normally 29.92 in-Hg at sea level decreasing at 1 in-Hg per 1000 ft of altitude (with no flow – pump disconnected)</p>	<p>If sample pressure is < 10 in-hg:</p> <ul style="list-style-type: none"> Blocked particulate filter Blocked sample inlet/gas line Failed pressure sensor/circuitry <p>If sample pressure is > 35 in-hg:</p> <ul style="list-style-type: none"> Blocked vent line on pressurized sample/zero/span gas supply Bad pressure sensor/circuitry
SYSTEM RESET	The computer has rebooted.	<p>This message occurs at power on. If it is confirmed that power has not been interrupted:</p> <ul style="list-style-type: none"> Failed +5 VDC power Fatal Error caused software to restart Loose connector/wiring
UV LAMP WARNING	The UV lamp intensity measured by the reference is outside of specified limits.	<ul style="list-style-type: none"> UV lamp is bad Reference detector is bad or out of adjustment. Mother board analog sensor input circuitry has failed. Fogged or damaged lenses/filters in UV light path A/D converter circuitry failure Light leak in reaction cell Shutter solenoid stuck in closed position
VACCUUM PRESS WARN	Vacuum pressure outside range allowed.	<ul style="list-style-type: none"> Pump may have failed Leak or obstruction in instrument's flow path

¹ Clears the next time successful span calibration is performed.

² Clears the next time successful zero calibration is performed.

³ Only appears if the IZS option is installed.



5.7.2 FAULT DIAGNOSIS WITH DASHBOARD FUNCTIONS

In addition to being useful as predictive diagnostic tools, the functions viewable in the Dashboard can be used to isolate and identify many operational problems when combined with a thorough understanding of the analyzer's principles of operation (see Section 6).

The acceptable ranges for these functions are listed in the "Nominal Range" column of the analyzer *Final Test and Validation Data Sheet* shipped with the instrument. Values outside these acceptable ranges indicate a failure of one or more of the analyzer's subsystems. Functions whose values are still within acceptable ranges but have significantly changed from the measurement recorded on the factory data sheet may also indicate a failure.

Make note of these values for reference in troubleshooting.

Note

Sample Pressure measurements are represented in terms of "Absolute Atmospheric Pressure" because this is the least ambiguous method for reporting gas pressure.

Absolute atmospheric pressure is about 29.92 in-Hg-A at sea level. It decreases about 1 in-Hg per 1000 ft gain in altitude. A variety of factors such as air conditioning systems, passing storms, and air temperature, can also cause changes in the absolute atmospheric pressure.



T100, T100U, T100H

Table 5-4. Dashboard Functions - Possible Causes for Out-of-Range Values

DASHBOARD FUNCTION	NOMINAL VALUES	POSSIBLE OUT-OF-RANGE CAUSE(S)
Stability	≤1 ppb with Zero Air	Faults that cause high stability values are: pneumatic leak; low or very unstable UV lamp output; light leak; faulty HVPS; defective preamp board; aging detectors; PMT recently exposed to room light; dirty/contaminated reaction cell.
Sample Flow	650 cm ³ /min ± 10%	Faults are caused due to: clogged critical flow orifice; pneumatic leak; faulty flow sensor; sample line flow restriction.
PMT	-20 to 150 mV with Zero Air	High or noisy readings could be due to: calibration error; pneumatic leak; excessive background light; aging UV filter; low UV lamp output; PMT recently exposed to room light; light leak in reaction cell; reaction cell contaminated HVPS problem. <i>It takes 24-48 hours for the PMT exposed to ambient light levels to adapt to dim light.</i>
Norm PMT	0-5000 mV, 0-20,000 ppb @ Span Gas Concentration	Noisy Norm PMT value (assuming unchanging SO ₂ concentration of sample gas); Calibration error; HVPS problem; PMT problem.
UV Lamp	2000 - 4000 mV	This is the instantaneous reading of the UV lamp intensity. Low UV lamp intensity could be due to: aging UV lamp; UV lamp position out of alignment; faulty lamp transformer; aging or faulty UV detector; UV detector needs adjusting; dirty optical components. Intensity lower than 600 mV will cause UV LAMP warning. Most likely cause is a UV lamp in need of replacement.
Lamp Ratio	30 TO 120%	The current output of the UV reference detector divided by the reading stored in the CPU's memory from the last time a UV Lamp calibration was performed (Utilities>Diagnostics menu). Out of range lamp ratio may be due to: malfunctioning UV lamp; UV lamp position out of alignment; faulty lamp transformer; aging or faulty UV detector; dirty optical components; pin holes or scratches in the UV optical filters; light leaks.
Stray Light	≤ 100 ppb / Zero Air	High stray light could be caused by: aging UV filter; contaminated reaction cell; light leak; pneumatic leak.
Dark Lamp	-50 to +200 mV	High dark PMT reading could be due to: light leak; shutter not closing completely; high pmt temperature; high electronic offset.
Dark PMT	-50 to +200 mV	High dark UV detector could be caused by: light leak; shutter not closing completely; high electronic offset.
HVPS	≈ 400 V to 900 V	Incorrect HVPS reading could be caused by; HVPS broken; preamp board circuit problems.
RCell Temp	50°C ± 1°C	Incorrect temperature reading could be caused by: malfunctioning heater; relay board communication (I ² C bus); relay burnt out
Box Temp	Ambient + ≈ 5°C	Incorrect temperature reading could be caused by: Environment out of temperature operating range; broken thermistor; runaway heater
PMT Temp	7°C ± 2°C Constant	Incorrect temperature reading could be caused by: TEC cooling circuit broken; High chassis temperature; 12V power supply
IZS (option) Temp	50°C ± 1°C	Malfunctioning heater; relay board communication (I ² C bus); relay burnt out
Pressure	Ambient ± 2 IN-HG-A	Incorrect sample gas pressure could be due to: pneumatic leak; malfunctioning valve; malfunctioning pump; clogged flow orifices; sample inlet overpressure; faulty pressure sensor
Slope	1.0 ± 0.3	Slope out of range could be due to: poor calibration quality; span gas concentration incorrect; leaks; UV Lamp output decay.
Offset	< 250 mV	High offset could be due to: incorrect span gas concentration/contaminated zero air/leak; low-level calibration off; light leak; aging UV filter; contaminated reaction cell; pneumatic leak.



5.7.3 USING THE DIAGNOSTIC SIGNAL I/O FUNCTIONS

The signal I/O functions in the Utilities>Diagnostics menu allows access to the digital and analog I/O in the analyzer. Some of the digital signals can be controlled through the Setup menu. These signals, combined with a thorough understanding of the instrument's principles of operation (Section 6), are useful for troubleshooting in three ways:

- The technician can view the raw, unprocessed signal level of the analyzer's critical inputs and outputs.
- Many of the components and functions that are normally under algorithmic control of the CPU can be manually exercised.
- The technician can directly control the signal level Analog and Digital Output signals.

This allows the technician to observe systematically the effect of directly controlling these signals on the operation of the analyzer. Use the Utilities>Diagnostics menu to view the raw voltage of an input signal or the Setup menu to control the state of an output voltage or control signal.

5.7.4 USING THE INTERNAL ELECTRONIC STATUS LEDs

Several color-coded LEDs are located inside the instrument to assist in determining if the analyzer's CPU, I²C communications bus and Relay board are functioning properly.

5.7.4.1 CPU STATUS INDICATOR

DS5, a red LED located on the motherboard (Figure 5-12), flashes when the CPU is running the main program loop. After power-up, approximately 30 – 60 seconds, DS5 should flash on and off. If the front panel displays properly but DS5 does not flash, then the program files may have become corrupted or the CPU may be defective; contact Teledyne API's Technical Support Department (see Section 5.9) because it may be possible to recover operation of the analyzer. If after 30 – 60 seconds DS5 is steadily off or steadily on, the CPU board is likely locked up and should the analyzer not respond (either with locked-up or dark front panel), then replace the CPU.

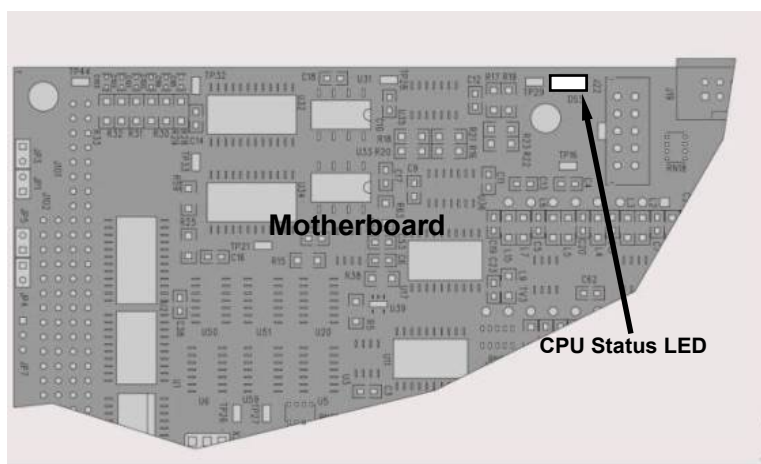

Figure 5-12. CPU Status Indicator



5.7.4.2 RELAY PCA WATCHDOG AND STATUS LEDs

There are several LEDs located on the Relay PCA (some are not used on this model), which indicate the status of the analyzer’s heating zones and valves. The most important of the LEDs is D1 (see Figure 5-13), which indicates the health of the CPU or the I²C bus: if either stops functioning, D1 will stay either ON or OFF, and after 30 seconds the “Watchdog Circuit” will automatically .

RELAY PCA STATUS LEDs

LEDs that remain continuously on or continuously off (not blinking) indicate a default state for their respective components as described in Table 5-5.

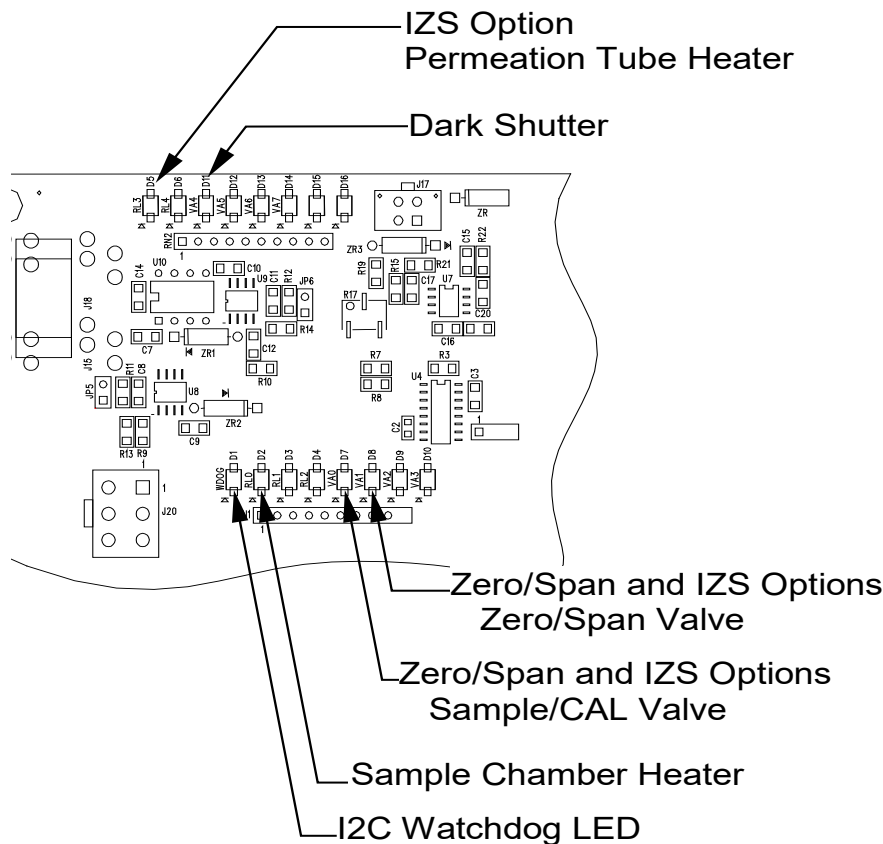

Figure 5-13. Relay PCA Status LED Locations



T100, T100U, T100H

Table 5-5. Relay PCA Watchdog and Status LED Failure Indications

LED	COLOR	FUNCTION	STATUS WHEN LIT	STATUS WHEN UNLIT
D1	RED	Watchdog circuit	Cycles On/Off every 3 seconds under control of the CPU. If steadily ON or OFF, it indicates failed CPU or faulty motherboard, valve driver board, or Relay board (or faulty connectors/wiring between them). Or failed/faulty +5 VDC power supply (PS1).	
D2	YELLOW	Sample chamber (RCELL) heater	HEATING	NOT HEATING
D3, D4	YELLOW	Unused	N/A	N/A
D5	YELLOW	IZS heater (option)	HEATING	NOT HEATING
D6	YELLOW	Unused	N/A	N/A
D7	GREEN	Zero / Span Valve	Valve open to Span Gas path	Valve open to Zero Gas (normal state)
D8	GREEN	Sample / Cal Valve	Valve open to calibration gas path	Valve open to sample gas inlet on rear panel (normal state)
D9, D10	GREEN	Unused	N/A	N/A
D11	GREEN	UV Lamp Shutter	Shutter open	Shutter closed
D12-14	GREEN	Unused	N/A	N/A

5.7.4.3 T100U SYNC DEMOD PCA LEDES

There are four green Light Emitting Diodes (LEDs) on the bottom left side of the Sync Demodulator PCA. They indicate various statuses and can be used to troubleshoot problems associated with the board.

Table 5-6: Relay PCA Status LED Failure Indications

INDICATOR	FUNCTION	DESCRIPTION	ACTION
DS4	Watchdog	Toggles on or off every second	Steady on or off controller on PCA has crashed, PMT temp. control still operates but PMT, REF and PMT Temp voltages as shown in test functions will be XXXX. Press reset button on sync demod to restart; if problem continues check power supply voltages on PCA or PCA is failing and must be replaced.
DS3	I2C Activity	Flashes each time sync demod is polled by instrument CPU once every 1 to 1.5 seconds	Steady on or off indicates I ² C bus failure check wiring harness taking I ² C to motherboard, another I ² C device is hanging bus, I ² C transceiver on motherboard has failed, or CPU has problem.
DS2	A/D Status 1	Short frequent flashes tracks timing of A/D converter	Lack of flash indicates internal failure of A/D or firmware. Press reset button on sync demod to restart; if problem continues check power supply voltages on PCA or PCA is failing and must be replaced.
DS1	A/D Status 2		



5.7.5 FLOW PROBLEMS

The standard analyzer has one main flow path. With the IZS option installed, there is a second flow path through the IZS oven that runs whenever the IZS is on standby to purge SO₂ from the oven chamber. The IZS flow is not measured so there is no reading for it on the front panel display. Refer to the flow diagrams (Section 2.3.3) for help in troubleshooting flow problems. In general, flow problems can be divided into three categories:

- Flow is too high
- Flow is greater than zero, but is too low, and/or unstable
- Flow is zero (no flow)

When troubleshooting flow problems, it is essential to confirm the actual flow rate without relying on the analyzer's flow display. The use of an independent, external, volumetric flow meter to perform a flow check as described in Section 5.6.6.3 is essential. Refer to the pneumatic flow diagrams as needed for reference.

5.7.5.1 SAMPLE FLOW IS ZERO OR LOW

On flow failure, the unit will display a SAMPLE FLOW WARNING in the Active Alerts page and the respective function (Dashboard or Home Meter, if configured to display) shows nothing instead of a numerical value.

Note

Sample and vacuum pressures mentioned in this chapter refer to operation of the analyzer at sea level. Pressure values need to be adjusted for elevated locations, as the ambient pressure decreases by about 1 in-Hg per 300 m / 1000 ft.

If the pump is not running, use an AC voltmeter to ensure that the pump is supplied with the proper AC power. If AC power is supplied properly but the pump is not running, replace the pump.

If the pump is operating but the unit is not reporting gas flow value, take the following three steps:

1. Check for actual sample flow:
 - Disconnect the sample tube from the sample inlet on the rear panel of the instrument.
 - Ensure that the unit is in basic SAMPLE mode.
 - Place a finger over the inlet and feel for suction by the vacuum or, more properly, use the flow meter to measure the actual flow.
 - If there is proper flow (within spec), contact Technical Support.
 - If there is no flow or low flow, continue with the next step.
2. Check pressures:
 - Check that the sample pressure is at or around 28 in-Hg-A at sea level (adjust as necessary when in elevated location, the pressure should be about 1" below ambient atmospheric pressure) and that the Rx Cell pressure is below 10 in-Hg-A.



T100, T100U, T100H

- The analyzer will calculate a sample flow up to about 14 in-Hg-A RCEL pressure but a good pump should always provide less than 10 in-Hg-A.
 - If both pressures are the same and around atmospheric pressure, the pump does not operate properly or is not connected properly. The instrument does not get any vacuum.
 - If both pressures are about the same and low (probably under 10 in-Hg-A, or ~20" on sample and 15" on vacuum), there is a cross-leak between sample flow path and vacuum, most likely through the dryer flow paths. See troubleshooting the dryer later in this chapter.
 - If the sample and vacuum pressures are around their nominal values (28 and <10 in-Hg-A, respectively) and the flow still displays no numerical value, carry out a leak check as described in Section 5.6.6.
 - If gas flows through the instrument during the above tests but goes to zero or is low when it is connected to zero air or span gas, the flow problem is not internal to the analyzer but likely caused by the gas source such as calibrators/generators, empty gas tanks, clogged valves, regulators and gas lines.
 - If an IZS or Zero/Span valve option is installed in the instrument, press Start in the Calibration>Zero and Span menus. If the sample flow increases, suspect a bad Sample/Cal valve.
3. If none of these suggestions help, carry out a detailed leak check of the analyzer as described in Section 5.6.6.2.

5.7.5.2 HIGH FLOW

Flow readings that are significantly higher than the allowed operating range (typically ± 10 -11% of the nominal flow) should not occur in the analyzer unless a pressurized sample, zero or span gas is supplied to the inlet ports.

- Ensure to vent excess pressure and flow just before the analyzer inlet ports.
- When supplying sample, zero or span gas at ambient pressure, a high flow could indicate a broken critical flow orifice (very unlikely case), allowing more than nominal flow, or were replaced with an orifice of wrong specifications.
- If the flows are within 15% above normal, we recommend measuring and recalibrating the flow electronically (Section 5.6.6.3), followed by a regular review of these flows over time to see if the new setting is retained properly.
- Also, check the flow assembly o-rings and replace as needed.

5.7.5.3 SAMPLE FLOW IS ZERO OR LOW BUT ANALYZER REPORTS CORRECT FLOW

The analyzer can report a correct flow rate even if there is no or a low actual sample flow through the reaction cell.

- The sample flow is only calculated from the sample pressure and critical flow condition is verified from the difference between sample pressure and vacuum pressure.
- If the critical flow orifice assembly is partially or completely clogged, both the sample and vacuum pressures are still within their nominal ranges (the pump keeps pumping, the sample port is open to the atmosphere), but there is no flow possible through the reaction cell.



T100, T100U, T100H

Although measuring the actual flow is the best method, in most cases, this fault can also be diagnosed by evaluating the sample pressure value.

- Since there is no longer any flow, the sample pressure should be equal to ambient pressure, which is about 1 in-Hg-A higher than the sample pressure under normal operation.
- Taken together with a zero or low actual flow, this could indicate a clogged sample orifice.

Again, monitoring the pressures and flows regularly will reveal such problems, because the pressures would slowly or suddenly change from their nominal, mean values. Teledyne API recommends reviewing all test data once per week and to do an exhaustive data analysis for test and concentration values once per month, paying particular attention to sudden or gradual changes in all parameters that are supposed to remain constant, such as the flow rates.

5.7.6 CALIBRATION PROBLEMS

This section describes possible causes of calibration problems.

5.7.6.1 NEGATIVE CONCENTRATIONS

Negative concentration values can be caused for several reasons:

- A slight, negative signal is normal when the analyzer is operating under zero gas and the signal is drifting around the zero calibration point. This is caused by the analyzer's zero noise and may cause reported concentrations to be negative for a few seconds at a time down to -5 ppb, but should alternate with similarly high, positive values.
- Miscalibration is the most likely explanation for negative concentration values. If the zero air contained some SO₂ gas (contaminated zero air or a worn-out zero air scrubber) and the analyzer was calibrated to that concentration as "zero", the analyzer may report negative values when measuring air that contains little or no SO₂. The same problem occurs, if the analyzer was zero-calibrated using ambient air or span gas.
- If the response Offset function for SO₂ is greater than 150 mV, a failed PMT or high voltage supply, or sample chamber contamination, could be the cause.

5.7.6.2 NO RESPONSE

If the instrument shows no response (display value is near zero) even though sample gas is supplied properly and the instrument seems to perform correctly.

1. Carry out an electrical test with the ELECTRICAL TEST procedure (Run ETest) in the Utilities>Diagnostics>OE Test menu. See Electrical Test (ETest) in Section 5.7.8.10.
 - If this test produces a concentration reading, the analyzer's electronic signal path is correct.
2. Carry out an optical test using the OPTIC TEST procedure (Run OTest) in the Utilities>Diagnostics>OE Test menu. See Optic Test (OTest) in Section 5.7.8.10.
 - If this test results in a concentration signal, then the PMT sensor and the electronic signal path are operating properly.



T100, T100U, T100H

- If the analyzer passes both ETest and OTest, it is capable of detecting light and processing the signal to produce a reading.
 - Therefore, the problem must be in the pneumatics, optics, or the UV lamp/lamp driver.
3. Confirm the lack of response by supplying SO₂ span gas of about 80% of the range value to the analyzer.
 4. Check the sample flow for proper value.
 5. Check for disconnected cables to the sensor module.

5.7.6.3 UNSTABLE ZERO AND SPAN

Leaks in the external gas supply and vacuum systems are the most common source of unstable and non-repeatable concentration readings.

1. Check for leaks in the pneumatic systems as described in Section 5.6.6.
2. Consider pneumatic components in the gas delivery system outside the analyzer such as a change in zero air source (ambient air leaking into zero air line or a worn-out zero air scrubber) or a change in the span gas concentration due to zero air or ambient air leaking into the span gas line.
3. Once the instrument passes a leak check, do a flow check (Section 5.6.6.3) to ensure that the instrument is supplied with adequate sample gas
4. Confirm the sample pressure, sample temperature, and UV lamp readings are correct and steady.
5. Verify that the sample filter element is clean and does not need to be replaced.

5.7.6.4 INABILITY TO SPAN - DEACTIVATED SPAN BUTTON

In general, the analyzer will deactivate certain buttons whenever the actual value of a parameter is outside of the expected range for that parameter. If the Span button is grayed out, the actual concentration must be outside of the range of the expected span gas concentration, which can have several reasons.

1. Verify that the expected concentration is set properly to the actual span gas concentration.
2. Confirm that the SO₂ span gas source is accurate.
 - This can be done by comparing the source with another calibrated analyzer, or by having the SO₂ source verified by an independent traceable photometer.
3. Check for leaks in the pneumatic systems as described in Section 5.6.6.
 - Leaks can dilute the span gas and, hence, the concentration that the analyzer measures may fall short of the expected concentration.
4. If the physical, low-level, hardware calibration has drifted (changed PMT response) or was accidentally altered by the user, a low-level calibration may be necessary to get the analyzer back into its proper range of expected values.
 - One possible indicator of this scenario is a slope or offset value that is outside of its allowed range (0.7-1.3 for slope, -20 to 150 for offsets). See Section 5.7.9.3 on how to carry out a low-level hardware calibration.



5.7.6.5 INABILITY TO ZERO - DEACTIVATED ZERO BUTTON

In general, the analyzer will deactivate certain buttons whenever the actual value of a parameter is outside of the expected range for that parameter. If the Zero button is grayed out, the actual gas concentration must be significantly different from the actual zero point (as per last calibration), which may be for any of several reasons.

1. Confirm that there is a good source of zero air. If the IZS option is installed, compare the zero reading from the IZS zero air source to a zero air source using SO₂-free air. Check any zero air scrubber for performance. It may need to be replaced (Section 5.6.3).
2. Check to ensure that there is no ambient air leaking into zero air line. Check for leaks in the pneumatic systems as described in Section 5.6.6.

5.7.6.6 NON-LINEAR RESPONSE

The analyzer was factory calibrated and should be linear to within 1% of full scale. Common causes for non-linearity are:

- Leaks in the pneumatic system. Leaks can add a constant of ambient air, zero air or span gas to the current sample gas stream, which may be changing in concentrations as the linearity test is performed. Check for leaks as described in Section 5.6.6.
- The calibration device is in error. Check flow rates and concentrations, particularly when using low concentrations. If a mass flow calibrator is used and the flow is less than 10% of the full scale flow on either flow controller, you may need to purchase lower concentration standards.
- The standard gases may be mislabeled as to type or concentration. Labeled concentrations may be outside the certified tolerance.
- The sample delivery system may be contaminated. Check for dirt in the sample lines or sample chamber.
- Calibration gas source may be contaminated.
- Dilution air contains sample or span gas.
- Sample inlet may be contaminated with SO₂ exhaust from this or other analyzers. Verify proper venting of the analyzer's exhaust.
- Span gas overflow is not properly vented and creates a back-pressure on the sample inlet port. Also, if the span gas is not vented at all and does not supply enough sample gas, the analyzer may be evacuating the sample line. Ensure to create and properly vent excess span gas.
- If the instrument is equipped with an internal IZS valve option and the SO₂ span value is continuously trending downward, the IZS permeation tube may require replacement.

5.7.6.7 DISCREPANCY BETWEEN ANALOG OUTPUT AND DISPLAY

If the concentration reported through the analog outputs does not agree with the value reported on the front panel, you may need to re-calibrate the analog outputs. This becomes more likely when using a low concentration or low analog output range. Analog outputs running at 0.1 V full scale should always be calibrated manually. See Section 2.5.8.1 for a detailed description of this procedure.



5.7.7 OTHER PERFORMANCE PROBLEMS

Dynamic problems (i.e. problems that only manifest themselves when the analyzer is monitoring sample gas) can be the most difficult and time consuming to isolate and resolve. The following section provides an itemized list of the most common dynamic problems with recommended troubleshooting checks and corrective actions.

5.7.7.1 EXCESSIVE NOISE

Excessive noise levels under normal operation usually indicate leaks in the sample supply or the analyzer itself.

- Ensure that the sample or span gas supply is leak-free and carry out a detailed leak check as described under Section 5.6.6.

Another possibility of excessive signal noise may be the preamplifier board, the high voltage power supply and/or the PMT detector itself.

- Contact the factory on troubleshooting these components.

5.7.7.2 SLOW RESPONSE

If the analyzer starts responding too slow to any changes in sample, zero or span gas, check for the following:

- Dirty or plugged sample filter or sample lines.
- Sample inlet line is too long.
- Dirty or plugged critical flow orifices. Check flows, pressures and, if necessary, change orifices (Section 5.6.4).
- Wrong materials in contact with sample - use glass or Teflon materials only. Porous materials, in particular, will cause memory effects and slow changes in response.
- Sample vent line is located too far from the instrument sample inlet causing a long mixing and purge time. Locate sample inlet (overflow) vent as close as possible to the analyzer's sample inlet port.
- Dirty sample cell.
- Insufficient time allowed for purging of lines upstream of the analyzer. Wait until stability is low.
- Insufficient time allowed for SO₂ calibration gas source to become stable. Wait until stability is low.

5.7.8 SUBSYSTEM CHECK FOR TROUBLESHOOTING

The preceding sections of this manual discussed a variety of methods for identifying possible sources of failures or performance problems within the analyzer. In most cases this included a list of possible causes and, in some cases, quick solutions or at least a pointer to the appropriate sections describing them. This section describes how to determine if a certain component or subsystem is actually the cause of the problem being investigated.



T100, T100U, T100H

5.7.8.1 AC MAIN POWER

ATTENTION

COULD DAMAGE INSTRUMENT AND VOID WARRANTY

Plugging the analyzer into a power supply that is too high a voltage or frequency can damage the pump and the AC Heaters.

Plugging the analyzer into a power supply that is too low a voltage or frequency will cause these components to not operate properly.

The analyzer’s electronic systems will operate with any of the specified power regimes. As long as system is connected to 100-120 VAC or 220-240 VAC at either 50 or 60 Hz it will turn on and after about 30 seconds show a front panel display. Internally, the status LEDs located on the Relay PCA, Motherboard and CPU should turn on as soon as the power is supplied.

- If they do not, check the circuit breaker built into the ON/OFF switch on the instrument’s front panel.



WARNING – ELECTRICAL SHOCK HAZARD

Should the AC power circuit breaker trip, investigate and correct the condition causing this situation before turning the analyzer back on.

If the pump and the heaters are not working correctly and incorrect power configuration is suspected, check the serial number label located on the instrument’s rear panel to ensure that the instrument was configured for the same voltage and frequency being supplied.

If the information included on the label matches the line voltage, but you still suspect an AC power configuration problem:

For the heaters, check the power configuration jumpers located on the relay board (refer to Figure 5-14).

- If the Jumper block is WHITE the heaters are configured for 115 VAC at 60 Hz.
- If the Jumper block is BLUE the heaters are configured for 220, 240 VAC at 50 Hz.

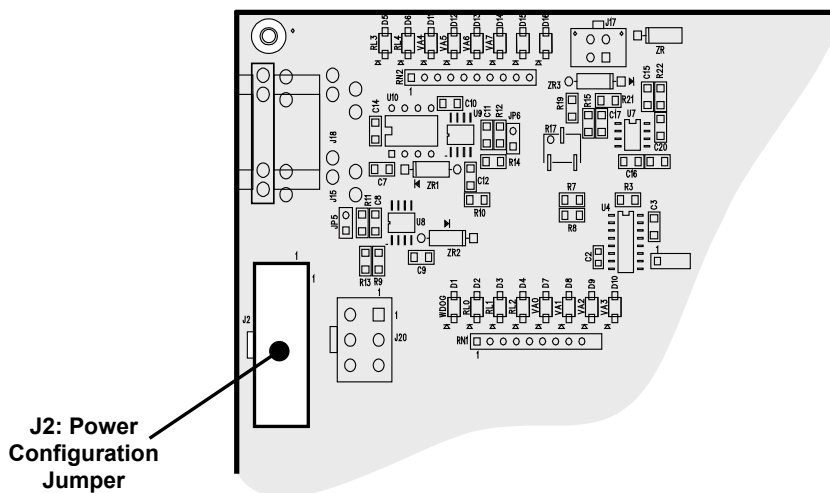

Figure 5-14. Location of Relay Board Power Configuration Jumper



T100, T100U, T100H

AC Configuration of the pump is accomplished via an in-line, hard wired, set of connections. Call Teledyne API's Technical Support Department for more information.

5.7.8.2 DC POWER SUPPLY

If the analyzer's AC mains power is working, but the unit is still not operating properly, there may be a problem with one of the instrument's switching power supplies, which convert AC power to 5 and ± 15 V (PS1) as well as +12 V DC power (PS2). The supplies can either have DC output at all or a noisy output (fluctuating).

To assist tracing DC Power Supply problems, the wiring used to connect the various printed circuit assemblies and DC powered components and the associated test points on the relay board follow a standard color-coding scheme as defined in Table 5-7.

Table 5-7. DC Power Test Point and Wiring Color Code

NAME	TEST POINT#	COLOR	DEFINITION
DGND	1	Black	Digital ground
+5V	2	Red	
AGND	3	Green	Analog ground
+15V	4	Blue	
-15V	5	Yellow	
+12V	6	Purple	
+12R	7	Orange	12 V return (ground) line

A voltmeter should be used to verify that the DC voltages are correct as listed in Table 5-8. An oscilloscope, in AC mode and with band limiting turned on, can be used to evaluate if the supplies are excessively noisy (>100 mV peak-to-peak).

Table 5-8. DC Power Supply Acceptable Levels

POWER SUPPLY	VOLTAGE	CHECK RELAY BOARD TEST POINTS				MIN V	MAX V
		FROM Test Point		TO Test Point			
		NAME	#	NAME	#		
PS1	+5	DGND	1	+5	2	+4.80	+5.25
PS1	+15	AGND	3	+15	4	+13.5	+16.0
PS1	-15	AGND	3	-15V	5	-14.0	-16.0
PS1	AGND	AGND	3	DGND	1	-0.05	+0.05
PS1	Chassis	DGND	1	Chassis	N/A	-0.05	+0.05
PS2	+12	+12V Ret	6	+12V	7	+11.8	+12.5
PS2	DGND	+12V Ret	6	DGND	1	-0.05	+0.05

5.7.8.3 I²C BUS

Verify operation of the I²C bus by checking whether the LEDs are flashing at the Relay PCA's D1 and the Valve Driver PCA's D2. If both are solid lit (not flashing) or are not on, and the DC power supplies are operating properly, there is a problem with the I²C bus.



5.7.8.4 LCD/DISPLAY MODULE

Assuming that there are no wiring problems and that the DC power supplies are operating properly, the display screen should light and show the splash screen and other indications of its state as the CPU goes through its initialization process. However, if pressing a control button on the touch screen does not change the display, either the touch-screen controller or the internal USB bus may be malfunctioning.

You can verify this failure by logging on to the instrument remotely with Teledyne API's NumaView™ Remote software. If the analyzer responds to remote commands and the display changes accordingly, the touch-screen interface may be faulty.

5.7.8.5 RELAY PCA

The Relay PCA can be most easily checked by observing the condition of its status LEDs (see Section 5.7.4.2), and using the Utilities>Diagnostics> menu (see Section 5.7.3) to toggle each LED ON or OFF.

If D1 on the relay board is flashing, but toggling an output using the I/O functions in the Utilities>Diagnostics menu does not toggle the output's status LED, then there is a circuit problem, or possibly a blown driver chip, on the relay board.

If D1 on the Relay PCA is flashing and the status indicator for the output in question (Heater power, Valve Drive, etc.) toggles properly using the I/O functions in the Utilities>Diagnostics menu, then the associated device or its control device (driver) on the Relay PCA is malfunctioning.

Several of the control devices are in sockets and can be easily replaced. The following table lists the control device associated with a particular function:

Table 5-9. Relay PCA Control Devices

FUNCTION	CONTROL DEVICE	SOCKETED
Valve0 – Valve3	U5	Yes
Valve4 – Valve7	U6	Yes
All heaters	K1-K5	Yes

5.7.8.6 MOTHERBOARD

A/D FUNCTIONS

The simplest method to check the operation of the A-to-D converter on the motherboard is to navigate to the Dashboard and check the two A/D reference voltages and input signals that can be easily measured with a voltmeter (configure the Dashboard to show the Ref 4096mV and Ref Ground parameters).

- The nominal value for **REF_4096_MV** is 4096 mV ± 10 mV.
- The nominal value for **REF_GND** is 0 mV ± 3 mV
 - If these signals are stable to within ±0.5 mV, the basic A/D converter is functioning properly.
 - If these values fluctuate largely or are off by more than specified above, one or more of the analog circuits may be overloaded or the motherboard may be faulty.



T100, T100U, T100H

Choose one parameter in the Dashboard function list such as **SAMPLE PRESSURE** (refer to previous section on how to measure it). Compare the voltage at its origin (refer to the Wiring Diagram in Appendix B with the voltage displayed). If the wiring is intact but there is a difference of more than ± 10 mV between the measured and displayed voltage, the motherboard may be faulty

STATUS OUTPUTS

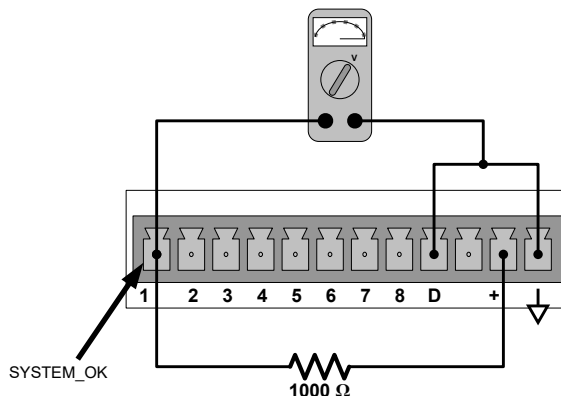

Figure 5-15. Typical Set Up of Status Output Test

To test the status output electronics:

1. Connect a jumper between the “D” pin and the “▽” pin on the status output connector.
2. Connect a 1000 ohm resistor between the “+” pin and the pin for the status output that is being tested.
3. Connect a voltmeter between the “▽” pin and the pin of the output being tested.
4. In the Utilities>Diagnostics>Digital Outputs menu (see Section 5.7.3), scroll through the outputs until you get to the output in question.
5. Alternately turn on and off the output noting the voltage on the voltmeter.
 - It should vary between 0 volts for ON and 5 volts for OFF.

CONTROL INPUTS

The control input bits can be tested by applying a trigger voltage to an input and watching changes in the analyzer’s Mode field at the bottom of the interface:

To test the “A” and “B” control inputs on the CONTROL IN connector:

1. Connect a jumper from the +5 V pin on the STATUS connector to the U on the CONTROL IN connector.
2. Connect a second jumper from the ▽ pin on the STATUS connector to the A pin on the CONTROL IN connector. The instrument should switch from **SAMPLE** mode to **ZERO CAL R** mode.
3. Connect a second jumper from the ▽ pin on the STATUS connector to the B pin on the CONTROL IN connector. The instrument should switch from **SAMPLE** mode to **SPAN CAL R** mode.



T100, T100U, T100H

In each case, the analyzer should return to SAMPLE mode when the jumper is removed.

5.7.8.7 PNEUMATIC PRESSURE / FLOW SENSOR ASSEMBLY

The pressure/flow sensor circuit board, located behind the sensor assembly, can be checked with a voltmeter using the following procedure, which assumes that the wiring is intact and that the motherboard and the power supplies are operating properly.

- Measure the voltage across TP1 and TP2, it should be 10.0 ± 0.25 V. If not, the board may be faulty and in need of replacement.
- Measure the voltage across capacitor C2; it should be 5.0 ± 0.25 V. If not, the board may be faulty and in need of replacement.

SAMPLE PRESSURE SENSOR CHECK

Measure the voltage across test points TP1 and TP4.

- With the sample pump disconnected or turned off, this voltage should be 4500 ± 250 mV.
- With the pump running, it should be about 0.2 V less as the sample pressure drops by about 1 in-Hg-A from ambient pressure.

If this voltage is significantly different, the pressure transducer S2 or the board may be faulty. A leak in the sample system to vacuum may also cause this voltage to be between about 0.6 and 4.5. Ensure that the front panel reading of the sample pressure is at about 1 in-Hg-A less than ambient pressure.

5.7.8.8 CPU

There are two major types of CPU board failures, a complete failure and a failure associated with the Disk on Module (DOM). If either of these failures occurs, contact the factory.

For complete failures, assuming that the power supplies are operating properly and the wiring is intact, the CPU is faulty if on power-on, the watchdog LED on the motherboard is not flashing.

- In some rare circumstances, this failure may be caused by a bad IC on the motherboard, specifically U57, the large, 44 pin device on the lower right hand side of the board. If this is true, removing U57 from its socket will allow the instrument to start up but the measurements will be invalid.
- If the analyzer stops during initialization (the front panel display shows a fault or warning message), it is likely that the DOM, the firmware or the configuration and data files have been corrupted.

5.7.8.9 RS-232 COMMUNICATIONS

GENERAL RS-232 TROUBLESHOOTING

Teledyne API's analyzers use the RS-232 communications protocol to allow the instrument to be connected to a variety of computer-based equipment. Problems with RS-232 connections usually center around 4 general areas:

- Incorrect cabling and connectors. See Section 2.3.1.7 under RS-232 Connection for connector and pin-out information.



T100, T100U, T100H

- The BAUD rate and protocol are incorrectly configured. See Section 2.3.1.7 under RS-232 Connection.
- If a modem is being used, additional configuration and wiring rules must be observed. See Sections 3.4 and 3.5.
- Incorrect setting of the DTE – DCE Switch. See Section 3.4 to set correctly.
- The cable (P/N 03596) that connects the serial COM ports of the CPU to J12 of the motherboard may not be properly seated (see Figure 2-12 for location of J12).

ANALYZER/MODEM OR TERMINAL OPERATION TROUBLESHOOTING

These are the general steps for troubleshooting problems with a modem connected to a Teledyne API analyzer.

1. Check cables for proper connection to the modem, terminal or computer.
2. Check to ensure that the DTE-DCE is in the correct position as described in Section 3.4.
3. Check to ensure that the set up command is correct.
4. Verify that the Ready to Send (RTS) signal is at logic high. The analyzer sets pin 7 (RTS) to greater than 3 volts to enable modem transmission.
5. Ensure that the BAUD rate, word length, and stop bit settings between modem and analyzer match.
6. Use the RS-232 test function to send “w” characters to the modem, terminal or computer.
7. Get your terminal, modem or computer to transmit data to the analyzer (holding down the space bar is one way); the green LED should flicker as the instrument is receiving data.
8. Ensure that the communications software or terminal emulation software is functioning properly.



5.7.8.10 PHOTOMULTIPLIER TUBE (PMT) SENSOR MODULE

The PMT detects the light emitted by the UV-excited fluorescence of SO₂ (see Principles of Operation, Section 6). It has a gain of about 500,000 to 1,000,000. It is not possible to test the detector outside of the instrument in the field. The basic method to diagnose a PMT fault is to eliminate the other components using ETEST, OTEST and specific tests for other sub-assemblies.

OPTIC TEST (OTEST)

The optic test function tests the response of the PMT sensor by turning on an LED located in the cooling block of the PMT (see Figure 5-25). The analyzer uses the light emitted from the LED to test its photo-electronic subsystem, including the PMT and the current to voltage converter on the pre-amplifier board.

- To ensure that the analyzer measures only the light coming from the LED, the analyzer should be supplied with zero air.
- The optic test should produce a PMT signal of about 2000±1000 mV.

To activate the optics test, go to the Utilities>Diagnostics>OE Test menu and press the Run OTest button.

Note

This is a coarse test for functionality and not an accurate calibration tool. The resulting PMT signal can vary significantly over time and also changes with low-level calibration.

ELECTRICAL TEST (ETEST)

The electrical test function creates a current, which is substituted for the PMT signal and feeds it into the preamplifier board.

- This signal is generated by circuitry on the pre-amplifier board itself and tests the filtering and amplification functions of that assembly along with the A/D converter on the motherboard.
- It does not test the PMT itself.
- The electrical test should produce a PMT signal of about 2000 ±1000 mV.

To activate the electrical test, go to the Utilities>Diagnostics>OETest menu and press the Run ETest button.

If the instrument passes the OTEST but fails the ETEST, the preamplifier board may be faulty or need a hardware calibration.

HIGH VOLTAGE POWER SUPPLY (HVPS)

The HVPS is located in the interior of the sensor module and is plugged into the PMT tube (refer to Figure 5-25). It requires 2 voltage inputs.

- The first is +15 V, which powers the supply.
- The second is the programming voltage which is generated on the preamplifier board.
- Adjustment of the HVPS is covered in the factory calibration procedure in Section 5.7.9.3.



T100, T100U, T100H

This power supply has 10 independent power supply steps, one to each pin of the PMT. The following test procedure below allows you to test each step.

1. Turn off the instrument.
2. Remove the cover and disconnect the 2 connectors at the front of the PMT housing.
3. Remove the end plate from the sensor (4 screws).
4. Remove the HVPS/PMT assembly from the cold block inside the sensor (2 plastic screws).
5. Unplug the PMT from the HVPS.
6. Re-connect the 7 pin connector to the sensor end cap, and power-up the instrument.
7. Navigate to the HVPS parameter in the Dashboard (if not shown, configure the Dashboard to display HVPS, Section 2.5.3).
8. Divide the displayed HVPS voltage by 10 and test the pairs of connector points as shown in the figure below, which uses 700 V as an example.
9. Check the overall voltage (should be equal to the HVPS value displayed in the Dashboard and the voltages between each pair of pins of the supply).

EXAMPLE: if the HVPS signal is 700 V the pin-to-pin voltages should be 70 V.

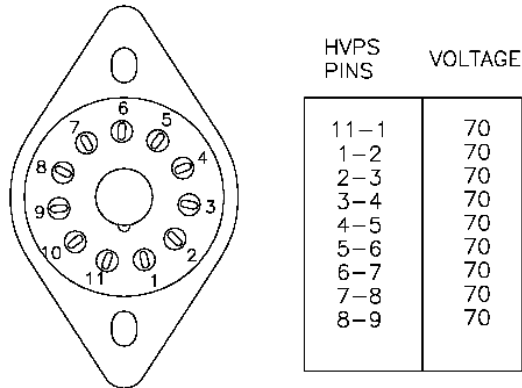

10. Turn off the instrument power, and reconnect the PMT tube, and then reassemble the sensor, including desiccant bag replacement per the Maintenance Schedule requirements (Section 5.1).
 - If any faults are found in the test, you must obtain a new HVPS as there are no user serviceable parts inside the supply.

5.7.8.11 PMT TEMPERATURE CONTROL PCA

The temperature control PCA is located on the sensor housing assembly, under the slanted shroud, next to the cooling fins and directly above the cooling fan.

If the red LED located on the top edge of this assembly is not glowing, the control circuit is not receiving power. Check the analyzer's power supply, the relay board's power distribution circuitry and the wiring that connects them to the PMT temperature control PCA.



T100, T100U, T100H

TEC CONTROL TEST POINTS

Four test points are also located at the top of this assembly they are numbered left to right start with the T1 point immediately to the right of the power status LED. These test points provide information regarding the functioning of the control circuit.

- To determine the current running through the control circuit, measure the voltage between T1 and T2. Multiply that voltage by 10.
- To determine the drive voltage being supplied by the control circuit to the TEC, measure the voltage between T2 and T3.
 - If this voltage is zero, the TEC circuitry is most likely open.
 - If the voltage between T2 and T3 = 0 VDC and the voltage measured between T1 and T2 = 0 VDC there is most likely an open circuit or failed op amp on control PCA itself.
 - If the voltage between T2 and T3 = 0 VDC and the voltage measured between T1 to T2 is some voltage other than 0 VDC, the TEC is most likely shorted.
- T4 is tied directly to ground. To determine the absolute voltage on any one of the other test points make a measurement between that test point and T4.

5.7.8.12 INTERNAL SPAN GAS (IZS) GENERATOR AND VALVE OPTIONS

If purchased, the zero/span valves and internal span gas generator options should be enabled. Check if the option is listed in the Setup>Instrument>Product Info page, and also check if the Span and Zero are in the Calibration menu. (Otherwise, contact the factory).

The semi-permeable PTFE membrane of the permeation tube is severely affected by humidity. Variations in humidity between day and night are usually enough to yield very variable output results. If the instrument is installed in an air-conditioned shelter, the air is usually dry enough to produce good results. If the instrument is installed in an environment with variable or high humidity, variations in the permeation tube output will be significant. In this case, a dryer for the supply air is recommended (dewpoint should be -20° C or less).

The permeation tube of the internal span gas generator option is heated with a proportional heater circuit and the temperature is maintained at $50^{\circ}\text{C} \pm 1^{\circ}\text{C}$. Check the IZS Temp in the Dashboard or the IZS Temp Raw signal in the Utilities>Diagnostics>Analog Inputs menu. At 50° C, the temperature signal from the IZS thermistor should be around 2500 mV.



5.7.8.13 TEMPERATURE SENSORS

BOX TEMPERATURE SENSOR

The box temperature sensor (thermistor) is mounted on the motherboard below the bottom edge of the CPU board when looking at it from the front. It cannot be disconnected to check its resistance.

- Box temperature will vary with, but will usually read about 5° C higher than, ambient (room) temperature because of the internal heating zones from the reaction cell and other devices.
- To check the box temperature functionality, we recommend checking the Box Temp signal voltage in the Utilities>Diagnostics>Analog Inputs menu (Section 5.7.3).
- At about 30° C, the signal should be around 1500 mV.
- To check the accuracy of the sensor, use a calibrated external thermometer / temperature sensor to verify the accuracy of the box temperature by:
- Placing it inside the chassis, next to the thermistor labeled XT1 (above connector J108) on the motherboard.
- Compare its reading to the value of the PMT TEMP.

PMT TEMPERATURE SENSOR CONTROL

The temperature of the PMT should be low and constant. It is more important that this temperature is maintained at a constant level than it is to be a specific temperature.

The PMT cooler uses a Peltier, thermo-electric cooler element supplied with 12 V DC power from the switching power supply PS2. The temperature is controlled by a proportional temperature controller located on the preamplifier board.

- Voltages applied to the cooler element vary from 0.1 to 12 VDC.
- The temperature set point (hard-wired into the preamplifier board) will vary by $\pm 1^\circ$ C due to component tolerances.
- The actual temperature will be maintained to within 0.1° C around that set point.

To check the operation of the PMT temperature control system:

1. Turn off the analyzer and let its internal components cool / heat to ambient temperature.
2. Turn on the analyzer.
3. Set the front panel to show the PMT TEMP function (Setup>Dashboard).
 - The temperature should fall steadily to 6-10° C.
 - If the temperature fails to drop after 20 minutes or to reach this point after 60 minutes, there is a problem in the cooler circuit.
 - If the control circuit on the preamplifier board is faulty, a temperature of -1° C will be reported.



5.7.9 SERVICE PROCEDURES

This section contains some procedures that may need to be performed when a major component of the analyzer requires repair or replacement.

Note

Regular maintenance procedures are discussed in Section 5.5 and are not listed here).

Also, there may be more detailed service notes for some of the below procedures. Contact Teledyne API's Technical Support Department.



WARNING – ELECTRICAL SHOCK HAZARD

Unless the procedure being performed requires the instrument to be operating, turn it off and disconnect power before opening the analyzer and removing, adjusting or repairing any of its components or subsystems.



CAUTION – QUALIFIED TECHNICIAN

The operations outlined in this chapter are to be performed by qualified maintenance personnel only.

5.7.9.1 DISK-ON-MODULE REPLACEMENT PROCEDURE

ATTENTION

COULD DAMAGE INSTRUMENT AND VOID WARRANTY

Servicing of circuit components requires electrostatic discharge protection, i.e. ESD grounding straps, mats and containers. Failure to use ESD protection when working with electronic assemblies will void the instrument warranty. For information on preventing ESD damage, refer to the manual, Fundamentals of ESD, PN 04786, which can be downloaded from our website at <http://www.teledyne-api.com> under Help Center > Product Manuals in the Special Manuals section.

Replacing the Disk-on-Module (DOM) will cause loss of all DAS data; it may also cause loss of some instrument configuration parameters unless the replacement DOM carries the exact same firmware version. Whenever changing the version of installed software, the memory must be reset. Failure to ensure that memory is reset can cause the analyzer to malfunction, and invalidate measurements. After the memory is reset, the A/D converter must be re-calibrated, and all information collected in Step 1 below must be re-entered before the instrument will function correctly. Also, zero and span calibration should be performed.

1. Document all analyzer parameters that may have been changed, such as range, auto-cal, analog output, serial port and other settings before replacing the DOM.
2. Turn off power to the instrument, fold down the rear panel by loosening the mounting screws.



T100, T100U, T100H

3. While looking at the electronic circuits from the back of the analyzer, locate the Disk-on-Module in the right-most socket of the CPU board.
4. The DOM should carry a label with firmware revision, date and initials of the programmer.
5. Remove the nylon standoff clip that mounts the DOM over the CPU board, and lift the DOM off the CPU. Do not bend the connector pins.
6. Install the new Disk-on-Module, making sure the notch at the end of the chip matches the notch in the socket.
7. It may be necessary to straighten the pins somewhat to fit them into the socket. Press the chip all the way in.
8. Close the rear panel and turn on power to the machine.
9. If the replacement DOM carries a firmware revision, re-enter all of the setup information.

5.7.9.2 SENSOR MODULE REPAIR AND CLEANING

This section presents steps for properly removing and reinstalling the sensor module prior to performing cleaning and repair procedures.

CAUTION – QUALIFIED PERSONNEL



While the PMT or HVPS can be removed through the front panel without un-mounting the entire sensor module, we recommend turning off the instrument, opening its top cover and removing the entire assembly so that further repairs can be carried out at an anti-ESD workstation.

Follow the guidelines for preventing electrostatic damage to electronic components, defined in the manual, Fundamentals of ESD, PN 04786, which can be downloaded from our website at <http://www.teledyne-api.com> under Help Center > Product Manuals in the Special Manuals section..

CAUTION – GENERAL SAFETY HAZARD



Do not look at the UV lamp while the unit is operating. UV light can cause eye damage. Always use safety glasses made from UV blocking material when working with the UV Lamp Assembly. (Generic plastic glasses are not adequate).



T100, T100U, T100H

Important

IMPACT ON READINGS OR DATA

- The sample chamber should only be opened or cleaned on instructions from the Teledyne API Technical Support Department.
- Be careful not to leave thumbprints on the interior of the sample chamber. The various oils that make up fingerprints fluoresce brightly under UV light and will significantly affect the accuracy of the analyzer's SO₂ measurement.
- After any repair or service has been performed on the sensor module, the T100 should be allowed to warm up for 60 minutes.
- Always perform a leak check and calibrate the analyzer before placing it back into service.

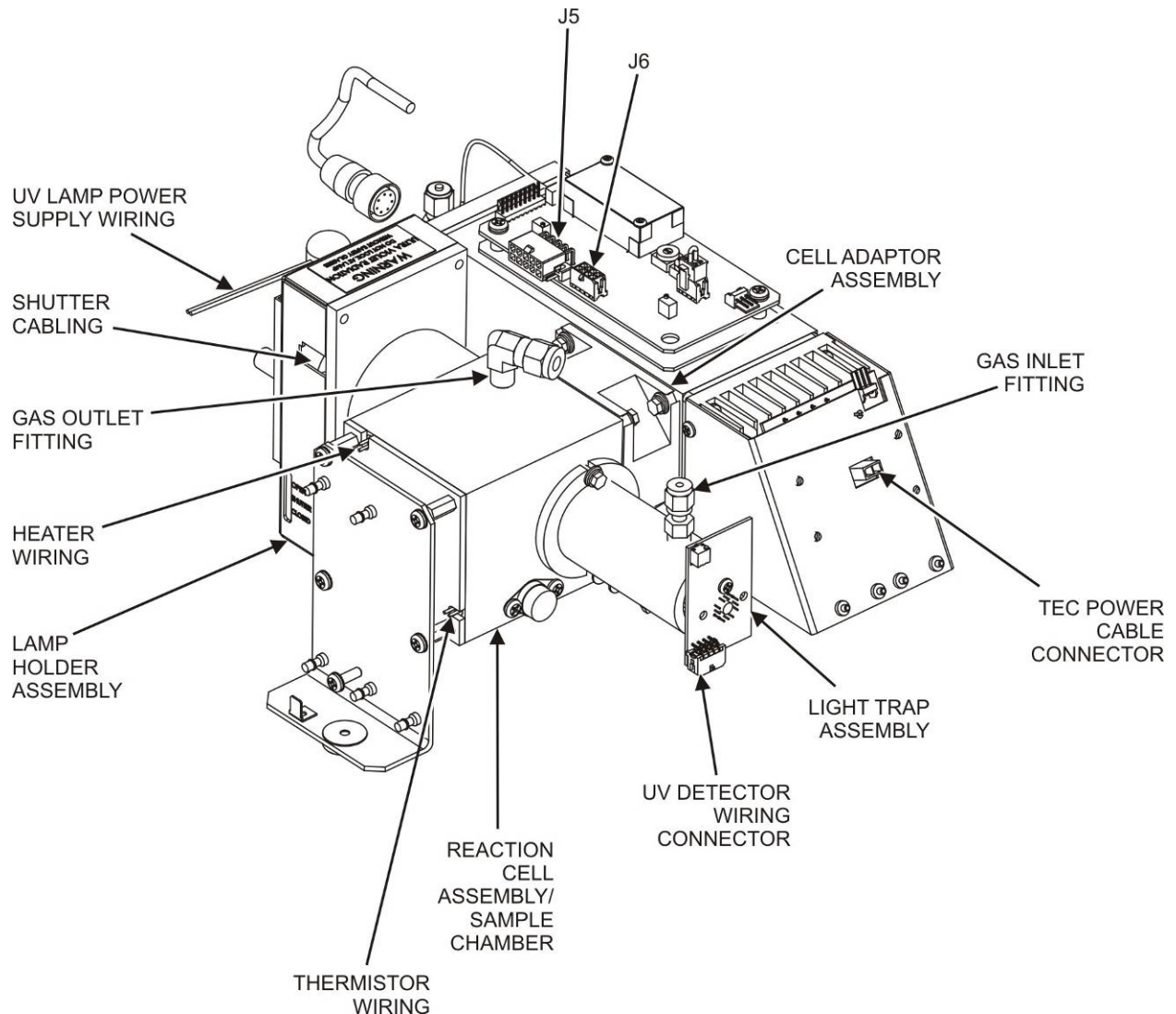

Figure 5-16. Sensor Module Wiring and Pneumatic Fittings

To remove the Sensor Module:

1. Turn off the instrument power.
2. Open the top cover of the instrument:
 - Remove the set screw located in the top, center of the rear panel.
 - Remove the screws fastening the top cover to the unit (four per side).
 - Lift the cover straight up.
3. Disconnect the sensor module pneumatic lines (refer to Figure 5-16)
 - Gas inlet line: 1/8" black Teflon® line with stainless steel fitting.
 - Gas outlet line: 1/4" black Teflon® line with brass fitting.
4. Disconnect all electrical wiring to the Sensor Module:
 - UV lamp power supply wiring
 - Shutter cabling
 - Reaction cell thermistor wiring (yellow)
 - Reaction cell heater wiring (red)
 - UV detector wiring
 - TEC power cable
 - PMT wiring (connectors J5 & J6 on the PMT preamplifier PCA)
5. Remove the three sensor module mounting screws.

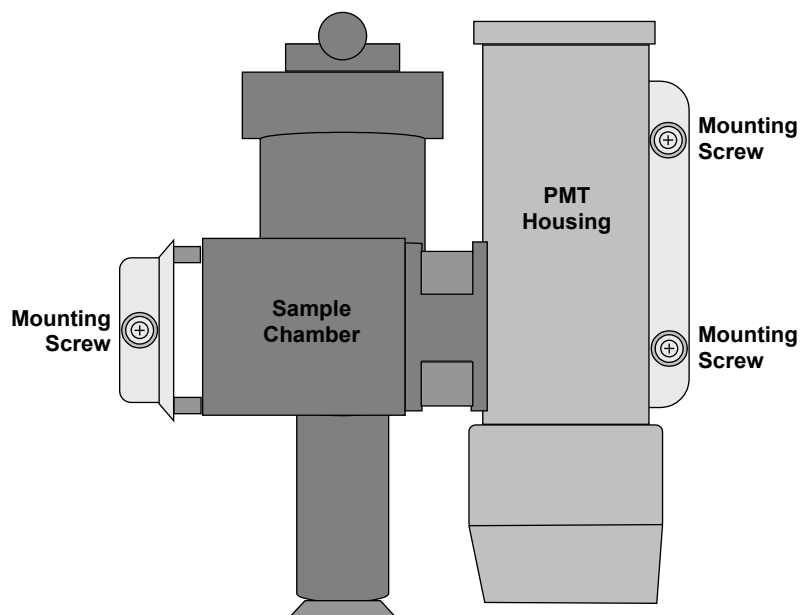

Figure 5-17. Sensor Module Mounting Screws

Follow the above steps in reverse order to reinstall the sensor module.



T100, T100U, T100H

CLEANING THE PMT LENS AND PMT FILTER

To clean the PMT Lens and filter:

1. Remove the sensor module as described above.

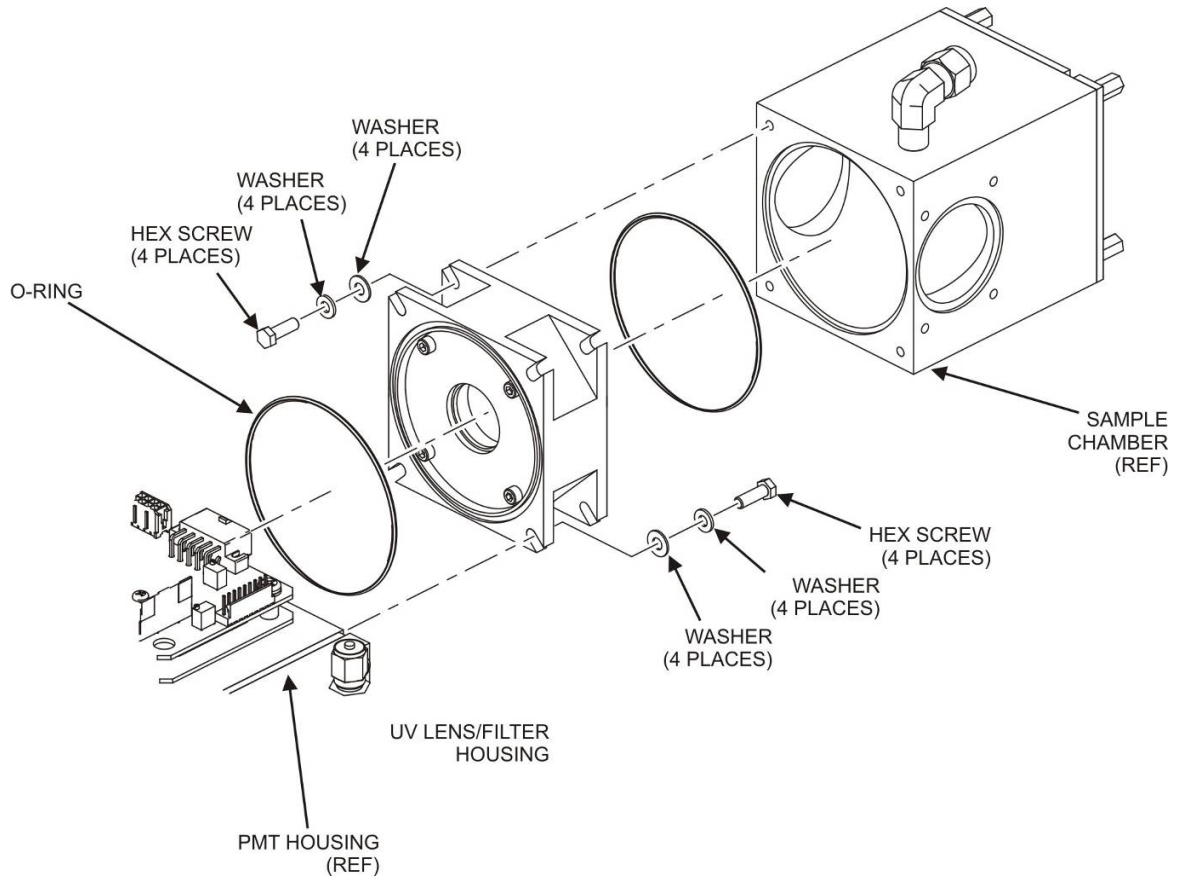

Figure 5-18. Hex Screw Between Lens Housing and Sample Chamber

2. Remove the sample chamber from the PMT lens and filter housing by unscrewing the 4 hex screws that fasten the chamber to the housing.
3. Remove the four lens cover screws.

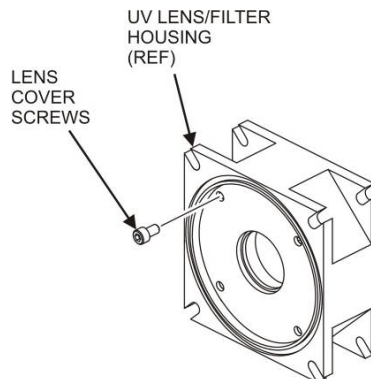

Figure 5-19. UV Lens Housing / Filter Housing



T100, T100U, T100H

4. Remove the lens/filter cover.
5. Carefully remove the PMT lens and set it aside on soft, lint-free cloth.
6. Remove the 3-piece, lens/filter spacer.
7. Carefully remove the PMT filter and set it aside on soft, lint-free cloth.

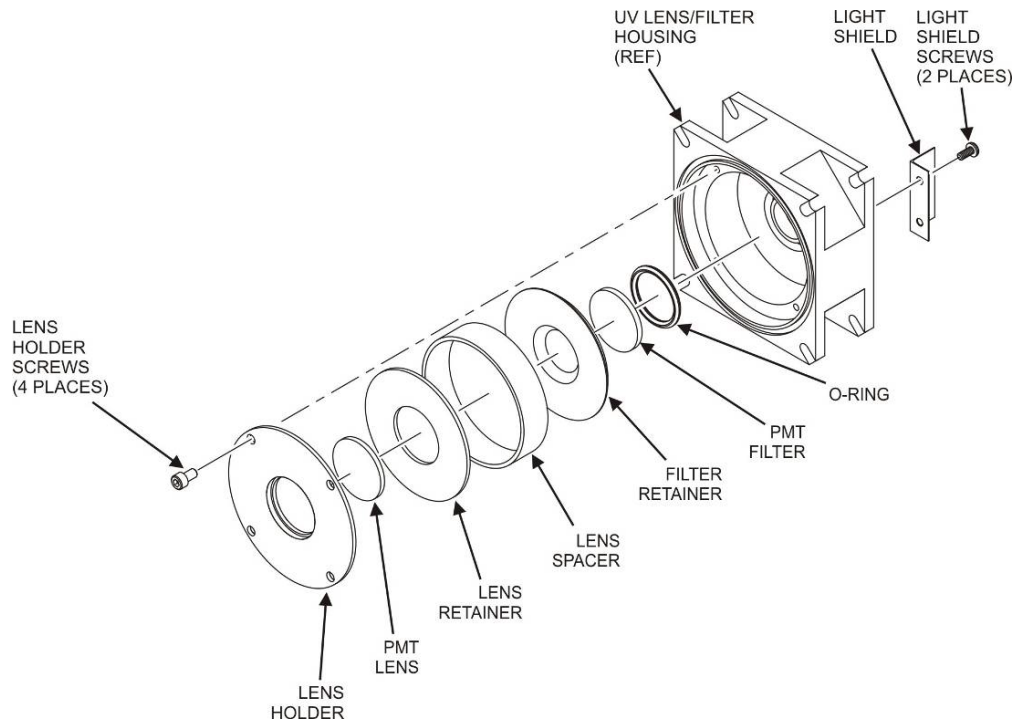

Figure 5-20. PMT UV Filter Housing Disassembled

8. Using a lint-free cloth dampened with distilled water, clean the lens, the filter and all of the housing assembly mechanical parts.
9. Dry everything with a 2nd lint-free cloth.
10. Referring to the illustrations presented, reassemble the lens/filter housing, ensuring to apply Loctite to the four lens holder screws and the two light shield screws.

Important

IMPACT ON READINGS OR DATA

Use gloves and a clean plastic covered surface during assembly. Cleanliness of the inside of the light shield, the UV lens filter housing and the PMT lens is especially important.



T100, T100U, T100H

REPLACING THE UV FILTER/LENS

To replace the UV filter lens:

1. Turn off the instrument's power and remove the power cord from the instrument.
2. Unplug J4 connector from the motherboard to allow tool access.
3. Alternatively, remove the sensor module as described above.
4. Remove 4 screws from the shutter cover (refer to the preceding figures that apply) and remove the cover.
5. Remove 4 screws from the UV filter retainer.

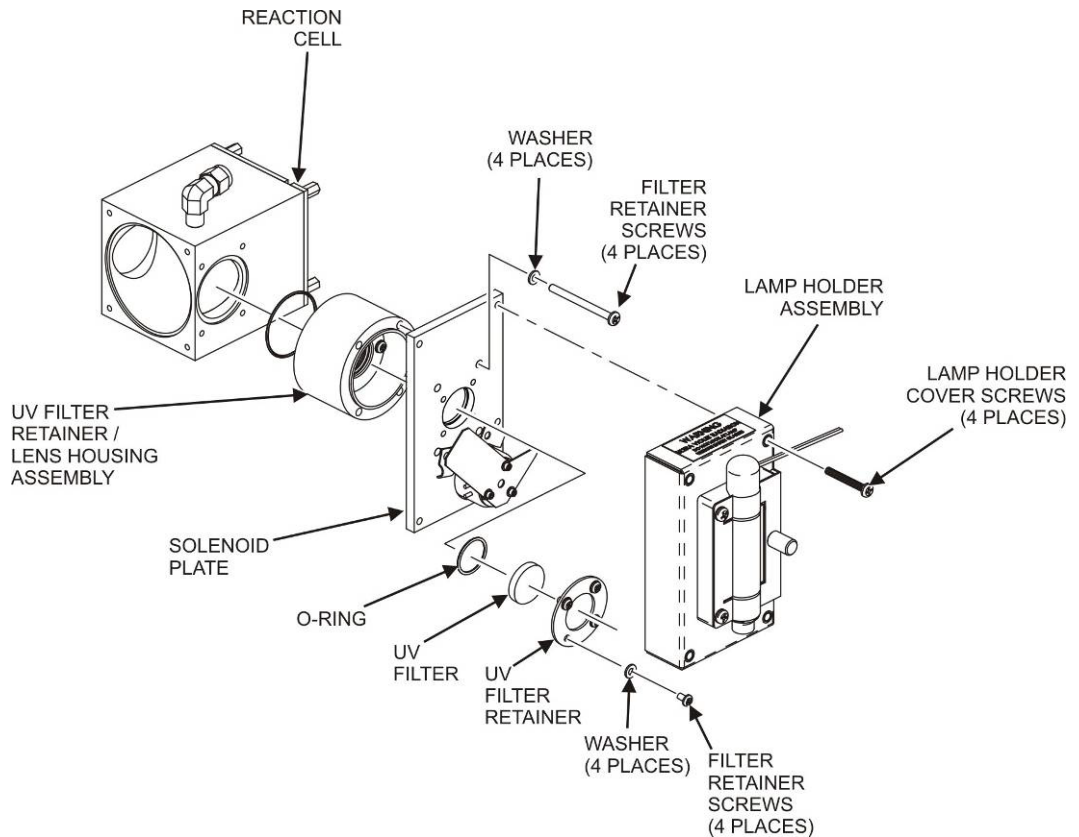

Figure 5-21. Disassembling the Shutter Assembly

6. Carefully remove the UV filter.
7. Install the UV filter with the arrow pointing toward the reaction cell. Handle carefully and never touch the filter's surface. UV filter's wider ring side should be facing out.
8. Install UV filter retainer and tighten screws.
9. Install the shutter cover and minifit connector. Tighten 4 shutter cover screws.
10. Reinstall the sensor module and Plug J4 connector into the motherboard.



T100, T100U, T100H

ADJUSTING THE UV LAMP (*PEAKING THE LAMP*)

There are three ways in which ambient conditions can affect the UV Lamp output and therefore the accuracy of the SO₂ concentration measurement. These are:

- **Line Voltage Change:** UV lamp energy is directly proportional to the line voltage. This can be avoided by installing adequate AC Line conditioning equipment such as a UPS/surge suppressor.
- **Lamp Aging:** Over a period of months, the UV energy will show a downward trend and can be up to 50% in the first 90 days, and then a slower rate, until the end of useful life of the lamp. Periodically running the UV lamp calibration routine (Utilities>Diagnostics menu) will compensate for this until the lamp output becomes too low to function at all.

Note that as the lamp degrades over time, the software for the CPU compensates for the loss of UV output.

- **Lamp Positioning:** The UV output level of the lamp is not even across the entire length of the lamp. Some portions of the lamp shine slightly more brightly than others. At the factory the position of the UV lamp is adjusted to optimize the amount of UV light shining through the UV filter/lens and into the reaction cell. Changes to the physical alignment of the lamp can affect the analyzer's ability to accurately measure SO₂.



CAUTION – GENERAL SAFETY HAZARD

Do not look at the UV lamp while the unit is operating. UV light can cause eye damage. Always use safety glasses made from UV blocking material when working with the UV Lamp Assembly. (Generic plastic glasses are not adequate).



T100, T100U, T100H

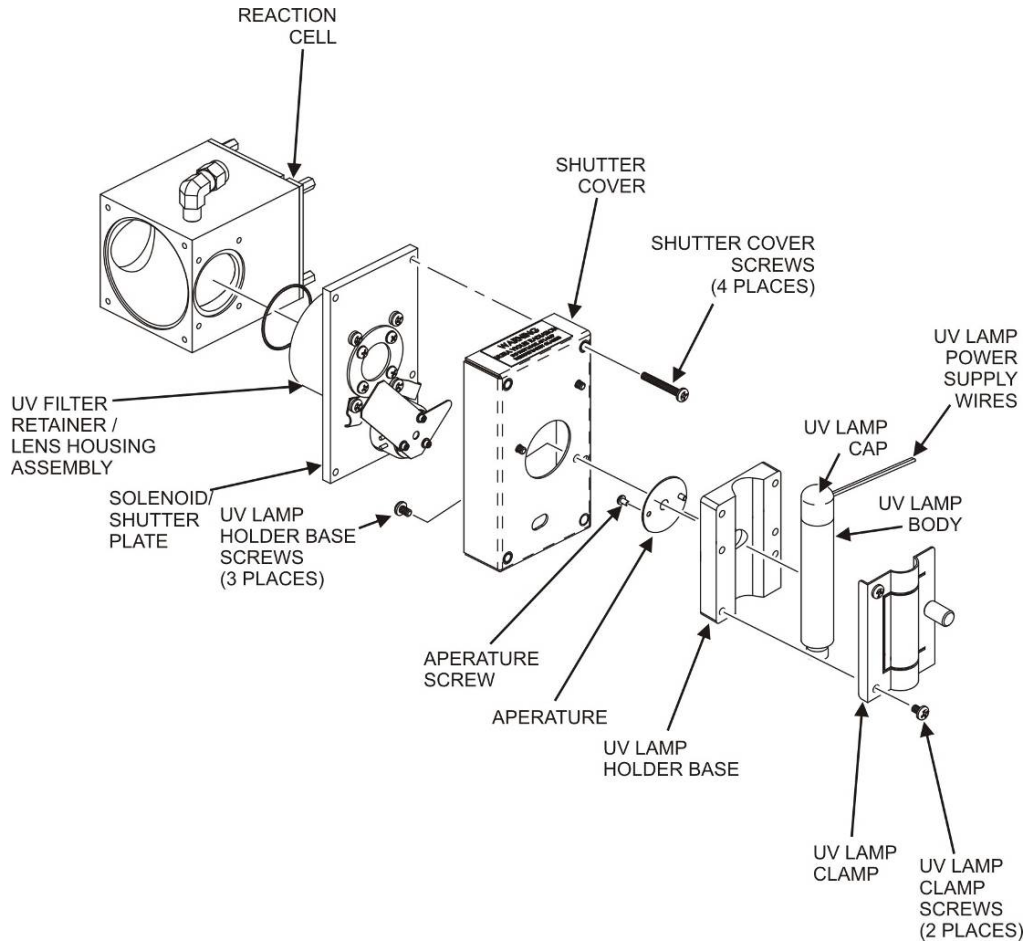

Figure 5-22. Shutter Assembly



T100, T100U, T100H

1. Set the Dashboard to show the **UV LAMP** function.
2. Slightly loosen the large brass thumbscrew located on the shutter housing (refer to Figure 5-23) so that the lamp can be moved.

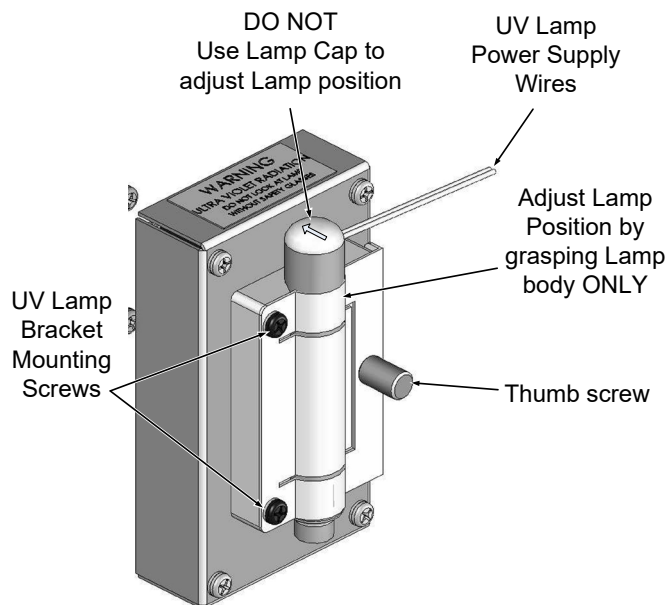

Figure 5-23. UV Lamp Adjustment

ATTENTION

COULD DAMAGE INSTRUMENT AND VOID WARRANTY
DO NOT grasp the UV lamp by its cap when changing its position - always grasp the main body of the lamp (refer to Figure 5-22). Inattention to this detail could twist and potentially disconnect the lamp's power supply wires.

3. While watching the **UV LAMP** reading, slowly rotate the lamp or move it back and forth vertically until the **UVLAMP** reading is at its maximum.
4. Compare the **UVLAMP** reading to the information in Table 5-10 and follow the instructions there.

Table 5-10. UV Lamp Signal Troubleshooting

UV LAMP SIGNAL	RECOMMENDED ACTION
4000 mV ±200 mV	No Action Required
> 4900mV at any time.	Adjust the UV reference detector potentiometer (Figure 5-24) until UV LAMP reads approximately 3600mV before continuing to adjust the lamp position.
> 4200 mV or < 3800 mV	Adjust the UV reference detector potentiometer (Figure 5-24) until UV LAMP reads as close to 3500mV as possible.
< 1000 mV	Replace the lamp



T100, T100U, T100H

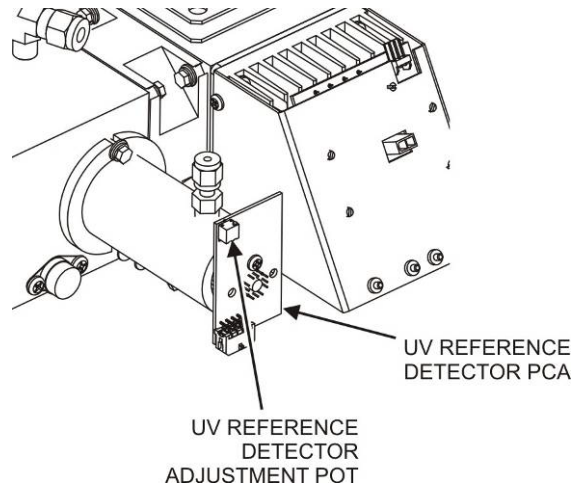

Figure 5-24. Location of UV Reference Detector Potentiometer

5. Finger tighten the thumbscrew.



CAUTION – GENERAL SAFETY HAZARD

DO NOT over tighten the thumbscrew, as over-tightening can cause breakage to the lamp and consequently release mercury into the area.

REPLACING THE UV LAMP

Note that the UV lamps differ between the T100 and the T100U; please call Technical Support for correct part number. To replace the UV Lamp:

1. Turn off the analyzer.
2. Disconnect the UV lamp from its power supply.
3. You can find the power supply connector by following the two, white UV Lamp power supply wires from the lamp to the power supply.
4. Loosen, but do not remove the two UV lamp bracket screws and the large brass thumbscrew located (refer to Figure 5-22 and Figure 5-23) on the shutter housing so that the lamp can be moved.

ATTENTION

COULD DAMAGE INSTRUMENT AND VOID WARRANTY
DO NOT grasp the UV lamp by its cap when changing its position - always grasp the main body of the lamp (refer to Figure 5-22) Inattention to this detail could twist and potentially disconnect the lamp's power supply wires.

5. Remove the UV Lamp by pulling it straight up.
6. Insert the new UV lamp into the bracket.



T100, T100U, T100H

7. Tighten the two UV lamp bracket screws, but leave the brass thumb screw un-tightened.
8. Connect the new UV lamp to the power supply.
9. Turn the instrument on and perform the UV adjustment procedure as defined in "Adjusting the UV Lamp (*Peaking the Lamp*)" above.
10. Finger tighten the thumbscrew.



CAUTION – GENERAL SAFETY HAZARD

DO NOT over tighten the thumbscrew, as over-tightening can cause breakage to the lamp and consequently release mercury into the area.

11. Calibrate the lamp (Utilities>Diagnostics menu).

REPLACING THE PMT, HVPS OR TEC IN THE T100

(Procedures for the T100U are found in the next subsection, "Replacing the PMT, HVPS or TEC in the T100U"). The photo multiplier tube (PMT) should last for the lifetime of the analyzer, however, the high voltage power supply (HVPS) or the thermo-electric cooler (TEC) components may fail. Replacing any of these components requires opening the sensor module. This is a delicate assembly and it is recommend that you ensure the PMT, HVPS or TEC modules are, indeed, faulty before unnecessarily opening of the module.

1. Turn OFF the analyzer and disconnect the power cord.
2. Remove the cover.
3. Disconnect all pneumatic and electrical connections from the sensor assembly.
4. Remove the sensor assembly.
5. If the TEC is to be replaced, remove the reaction cell assembly at this point by unscrewing two holding screws.
 - This is necessary only if the repair being performed involves removing the PMT cold block.



T100, T100U, T100H

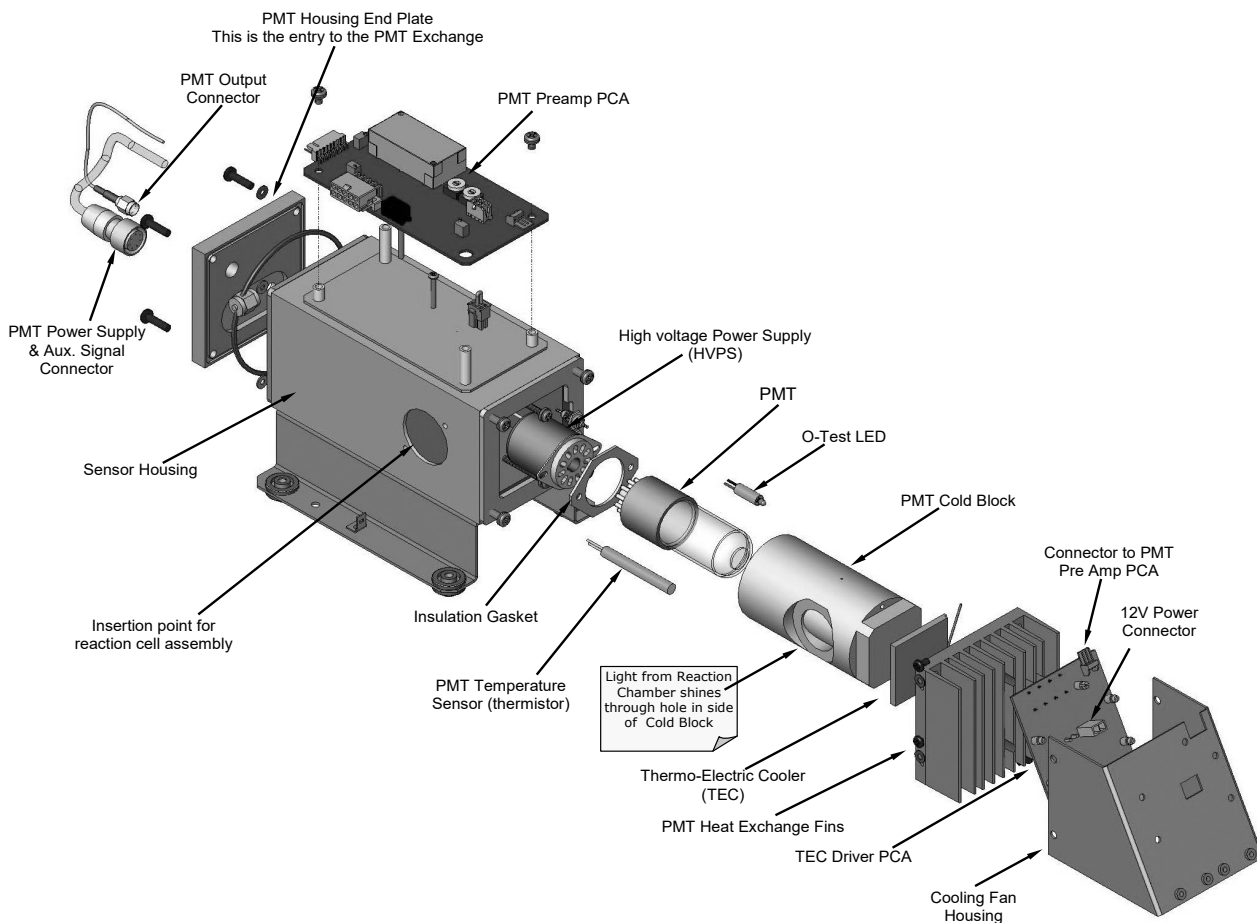

Figure 5-25. T100 Sensor Assembly

6. Remove the two connectors on the PMT housing end plate facing towards the front panel.
7. Remove the end plate itself (4 screws with plastic washers).

Note

Any time the black PMT housing end plate for the Sensor Assembly is removed, replace the five desiccant bags inside the housing.

8. Remove the desiccant bags from the PMT housing.
9. Unscrew the PMT assembly, which is held to the cold block by two plastic screws.
10. Discard the plastic screws and replace with new screws at the end of this procedure (the threads get stripped easily and it is recommended to use new screws).
11. Along with the plate, slide out the optic test (O-Test) LED and the thermistor that measures the PMT temperature.
 - Thermistor will be coated with a white, thermal conducting paste.
 - Do not contaminate the inside of the housing with this grease, as it may contaminate the PMT glass tube on re-assembly.
12. Carefully take out the assembly consisting of the HVPS, the insulation gasket and the PMT.



T100, T100U, T100H

13. Change the PMT or the HVPS or both, clean the PMT glass tube with a clean, anti-static wipe and do not touch it after cleaning.
14. If the cold block or TEC is to be changed:
 - Disconnect the TEC driver board from the preamplifier board, remove the cooler fan duct (4 screws on its side) including the driver board.
 - Disconnect the driver board from the TEC and set the sub-assembly aside.
15. Remove the end plate with the cooling fins (4 screws) and slide out the PMT cold block assembly, which contains the TEC.
16. Unscrew the TEC from the cooling fins and the cold block and replace it with a new unit.
17. Reassemble this TEC subassembly in reverse order.
 - Ensure to use thermal grease between TEC and cooling fins as well as between TEC and cold block and that the side opening in the cold block will face the reaction cell when assembled.
 - Evenly tighten the long mounting screws for good thermal conductivity.



CAUTION – QUALIFIED PERSONNEL

The thermo-electric cooler needs to be mounted flat to the heat sink.

If there is any significant gap, the TEC might burn out. Ensure to apply heat sink paste before mounting it and tighten the screws evenly and cross-wise.

18. Reinsert the TEC subassembly in reverse order.
 - Ensure that the O-ring is seated properly and the assembly is tightened evenly.
19. Insert the O-Test LED and thermistor into the cold block, insert new desiccant bags and carefully replace the end plate by making sure that the O-ring is properly in place.
 - Improperly placed O-rings will cause leaks, which – in turn – cause moisture to condense on the inside of the cooler and likely cause a short in the HVPS.
20. Reinsert the PMT/HVPS subassembly in reverse order.
 - Don't forget the insulation gasket between HVPS and PMT.
 - Use new plastic screws to mount the PMT assembly on the PMT cold block.
21. Install new silica gel packets (desiccant bags).
22. Reconnect the cables and the reaction cell (evenly tighten these screws).
23. Replace the sensor assembly into the chassis and fasten with four screws and washers.
24. Reconnect all electrical and pneumatic connections.
25. Leak check the system (see Section 5.6.6).
26. Turn ON the analyzer.



T100, T100U, T100H

27. Verify the basic operation of the analyzer using the ETEST and OTEST features (Section 5.7.8.10) or zero and span gases, then carry out a hardware calibration of the T100 analyzer (Section 5.7.9.3) followed by a zero/span point calibration (Section 4.5.1).

REPLACING THE PMT, HVPS OR TEC IN THE T100U

The PMT should last for the lifetime of the analyzer. However, in some cases, the high voltage power supply (HVPS) or the thermo-electric cooler (TEC) may fail. To replace the PMT, the HVPS or the TEC:

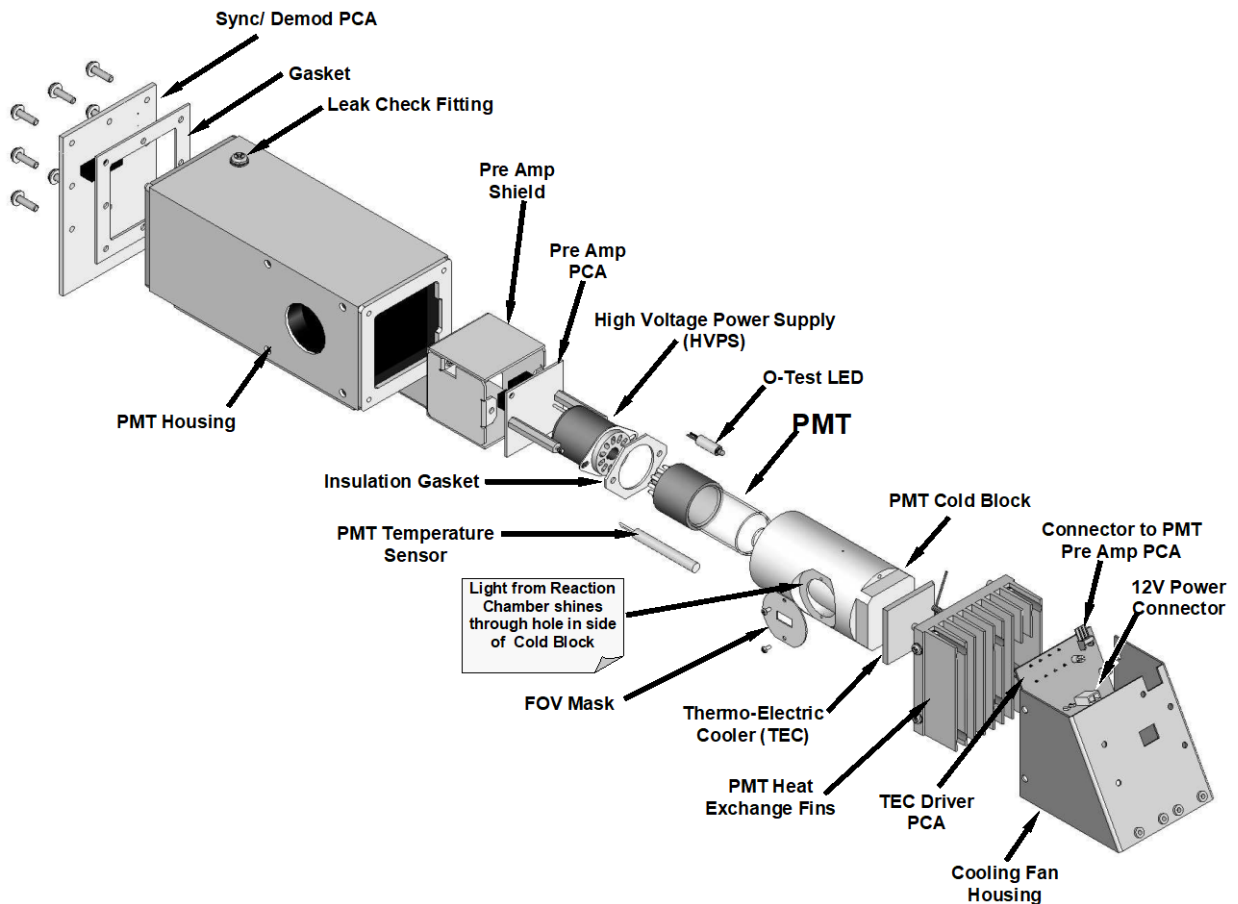

Figure 5-26. T100U Sensor Assembly

1. Power down the analyzer, disconnect the power cord, remove the cover and disconnect all pneumatic and electrical connections from the sensor assembly.
2. Remove the entire sensor module assembly from the analyzer.
3. Remove the fluorescence cell assembly.
4. Remove the two connectors on the Sync Demod board.
5. Remove the Sync Demod Board (6 screws with plastic washers). Disconnect the electrical connector that leads to the preamp board further inside the housing.
6. Remove all of the desiccant bags inside the PMT housing.



T100, T100U, T100H

7. Along with the plate, slide out the OPTIC TEST LED and the thermistor that measures the PMT temperature.
 - The thermistor will be coated with a white, thermal conducting paste. Do not contaminate the inside of the housing or the PMT tube with this grease.
8. Unscrew the PMT assembly. It is held to the cold block by two plastic screws.
 - Because the threads of the plastic screws are easily damaged it is highly recommended to use new screws when reassembling the unit.
9. Carefully take out the assembly consisting of the HVPS, the gasket, preamp assembly and the PMT.
10. Change the PMT or the HVPS or both, clean the PMT glass tube with a clean, anti-static wipe and do not touch it after cleaning.
11. If the cold block or TEC is to be changed, disconnect the TEC driver board from the pre-amplifier board:
 - a. Remove the cooler fan duct (4 screws on its side) including the driver board.
 - b. Disconnect the driver board from the TEC and set the sub-assembly aside.
 - c. Remove the end plate with the cooling fins (4 screws) and slide out the PMT cold block assembly, which contains the TEC.
 - d. Unscrew the TEC from the cooling fins and the cold block and replace it with a new unit.
12. Re-assemble the TEC subassembly in reverse order.

CAUTION – QUALIFIED PERSONNEL



The thermo-electric cooler needs to be mounted flat to the heat sink.

If there is any significant gap, the TEC might burn out. Ensure to apply heat sink paste before mounting it and tighten the screws evenly and cross-wise.

- a. Make sure to use thermal pads (HW-405) between the TEC and the cooling fins as well as between the TEC and the cold block.
 - b. Align the side opening in the cold block with the hole in the PMT housing where the sample Chamber attaches.
 - c. Evenly tighten the long mounting screws for good thermal conductivity.
13. Re-insert the TEC subassembly.
 - Make sure that the O-ring is placed properly and the assembly is tightened evenly.
14. Insert the LED and thermistor into the cold block.
15. Re-insert the PMT/HVPS subassembly.
 - Don't forget the gasket between HVPS and PMT.
 - Use new plastic screws to mount the PMT assembly on the PMT cold block.
16. Insert the new desiccant bags.



T100, T100U, T100H

17. Reconnect the cable from the preamp board to the back of the Sync Demod board then carefully reattach the Sync Demod board to the housing.
 - Make sure that the gasket is between the back of the board and the front of the PMT housing.
 - Be sure to tighten these screws evenly,
18. Reconnect the cables and the reaction cell.
19. Replace the sensor assembly into the chassis and fasten with four screws and washers.
20. Reconnect all electrical and pneumatic connections, leak check the system and power up the analyzer.
 - Verify the basic operation of the analyzer using the ETEST and OTEST features (see Section 5.9.4 & 5.9.5 of the T100 Manual) or by measuring calibrated zero and span gases.
21. Perform a PMT hardware calibration for the T100U (Section 5.7.9.4).
22. Perform a zero point and span calibration (Section 4.5.1).

5.7.9.3 T100 PMT SENSOR HARDWARE CALIBRATION (“FACTORY CAL”)

(Procedures for the T100U are found in Section 5.7.9.4). The sensor module hardware calibration is used in the factory to adjust the slope and offset of the PMT output and to optimize the signal output and HVPS.

- If the instrument’s slope and offset values are outside the acceptable range and all other more obvious causes for this problem have been eliminated, the hardware calibration can be used to adjust the sensor as was done in the factory.
- This procedure is also recommended after replacing the PMT or the preamplifier board.

To calibrate the PMT preamplifier PCA:

1. Perform a full zero point calibration using zero air (see Section 4.5.1.1).
2. Display the Stability value either on the SO₂ plot by clicking the SO₂ label or value in the display, or if configured in a Home page meter (Section 2.5.6) or in the Dashboard (Section 2.5.3).
3. Locate the preamplifier board (PMT Preamp PCA) (see Figure 2-3).
4. Locate the following components on the preamplifier board (Figure 5-27):
 - HVPS coarse adjustment switch (Range 0-9, then A-F).
 - HVPS fine adjustment switch (Range 0-9, then A-F).
 - Gain adjustment potentiometer (Full scale is 10 turns).
5. Turn the gain adjustment potentiometer 12 turns clockwise or to its maximum setting.
6. Feed SO₂ gas into the analyzer.
 - This should be 90% of the upper limit setting for the analyzer’s reporting range:

EXAMPLE: if the reporting range is set at 500 ppb, use 450 ppb SO₂.

7. Wait until the Stability is below 0.5 ppb

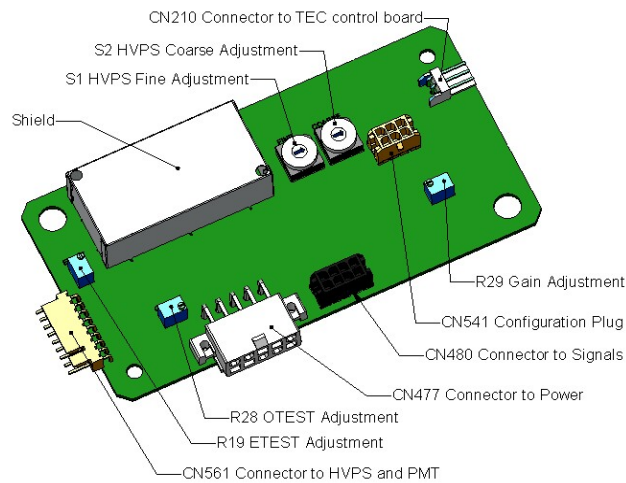

Figure 5-27. Pre-Amplifier Board Layout

8. In the Dashboard view and record the Offset function.
9. Then view the NORM PMT in the Dashboard, and determine the target Norm PMT value according to the following formulae:
 - If the reporting range is set for $\leq 2,000$ ppb (the instrument will be using the 2,000 ppb physical range), then target **NORM PMT** = (2 x span gas concentration) + **OFFSET**.
If the reporting range is set for $\geq 2,001$ ppb (the instrument will be using the 20,000 ppb physical range), then target **NORM PMT** = (0.181 x span gas concentration) + **OFFSET**.
EXAMPLE: If the **OFFSET IS** 33 mV, the Reporting Range is 500 ppb, the span gas should be 400 ppb and the calculation would be:

 Target **NORM PMT** = (2 x 400) + 33 mV
 Target **NORM PMT** = 833 mV
10. Set the HVPS coarse adjustment to its minimum setting (0).
11. Set the HVPS fine adjustment switch to its maximum setting (F).
 - Set the HVPS coarse adjustment switch to the lowest setting that will give you just above the target value for NORM PMT signal.

ATTENTION

COULD DAMAGE INSTRUMENT AND VOID WARRANTY

Do not overload the PMT by accidentally setting both adjustment switches to their maximum setting. Start at the lowest setting and increment slowly: no sooner than every 10 seconds between adjustments.

12. Adjust the HVPS fine adjustment such that the NORM PMT value is close to the target value.
 - It may be necessary to go back and forth between coarse and fine adjustments if the proper value is at the threshold of the min/max coarse setting.



T100, T100U, T100H

13. Perform a span point calibration (Section 4.5.1.2) to normalize the sensor response to its new PMT sensitivity.
14. Review the slope and offset values:
 - The slope values should be 1.000 ± 0.300 .
 - The offset values should be approximately 0.0 (-20 to +150 mV is allowed).

5.7.9.4 T100U PMT SENSOR HARDWARE CALIBRATION (“FACTORY CAL”)

This procedure applies to the T100U.

The sensor module hardware calibration adjusts the slope of the PMT output when the Instruments slope and offset values are outside of the acceptable range and all other more obvious causes for this problem have been eliminated. Because the PMT HV is remotely controlled and there is no PMT preamp gain adjust, this procedure is done automatically through the analyzer software.

1. Set the instrument reporting range to SNGL & 500 ppb (Setup>Vars menu)
2. Perform a full zero–point calibration using zero air.
3. Let the instrument stabilize by allowing it to run for one hour.
4. Adjust the UV Lamp (under Section 5.7.9.2).
5. Perform a Lamp Calibration (Utilities>Diagnostics>Lamp Cal).
6. Feed 400 ppb span gas into the analyzer.
7. Wait approximately 30-60 minutes (or until the stability reads ≤ 0.1 ppb), then go to the Utilities>Diagnostics>PMT Cal menu.
8. Either press Calibrate if you are using 400 ppb, or change the concentration value to what is appropriate and then press Calibrate.
9. Select the range that you wish to setup (low, Range 1, or high, Range 2).
10. Wait two to three minutes until you get a message that indicates the HV has been adjusted successfully.

Important

IMPACT ON READINGS OR DATA

If a reporting range other than 500 ppb is used in this procedure, use a span gas equal to 80% of the reporting range and adjust the PMT to target a NORM PMT value of twice the ppb value of the span gas.

EXAMPLE: If the reporting range is 800 ppb, then set the target concentration to 640 ppb for this procedure.

11. Wait until the **STABIL** value is ≤ 0.1 ppb.
12. Scroll to the NORM PMT value and verify that it is approximately twice the ppb value of the span gas.
13. Perform a zero / span calibration.
14. Check the slope and offset values and compare them to the values in Table 4-4.
15. Steps 7 - 14 may have to be performed more than once in order to compensate for any over/undershooting of the PMT reading based on the adjusted HVPS drive voltage. Best results occur after performing the PMT calibration (steps 7 - 14) at least two consecutive times.



5.7.9.5 REMOVING / REPLACING THE RELAY PCA FROM THE INSTRUMENT

This is the most commonly used version of the Relay PCA. It includes a bank of solid state AC relays. This version is installed in analyzers where components such as AC powered heaters must be turned ON & OFF.

A retainer plate is installed over the relay to keep them securely seated in their sockets.

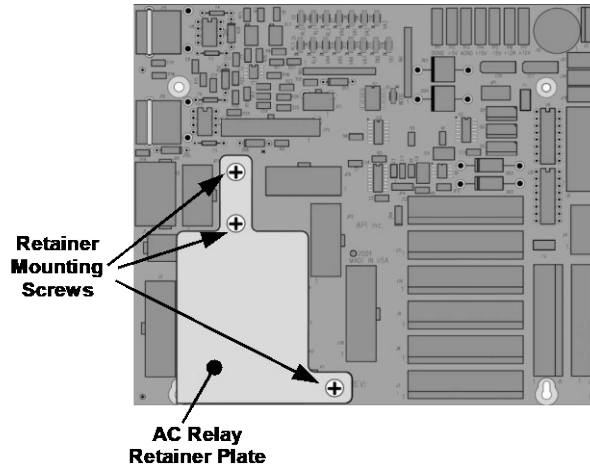

Figure 5-28. Relay PCA with AC Relay Retainer In Place

The Relay retainer plate installed on the relay PCA covers the lower right mounting screw of the relay PCA. Therefore, when removing the relay PCA, the retainer plate must be removed first.

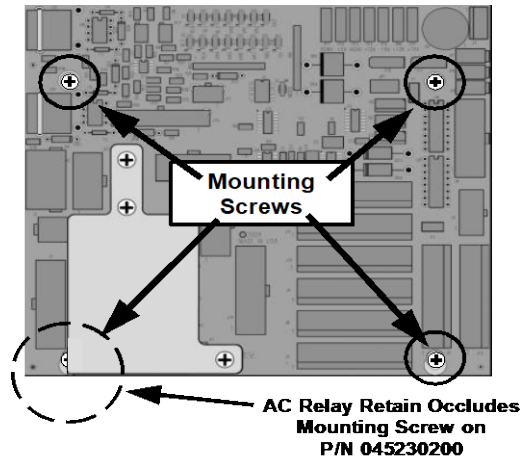

Figure 5-29. Relay PCA Mounting Screw Locations



5.8 FREQUENTLY ASKED QUESTIONS

The following list was compiled from the Teledyne API's Technical Support Department's ten most commonly asked questions relating to the analyzer.

QUESTION	ANSWER
Why does the ENTR button sometimes disappear on the front panel display?	Sometimes the ENTR button will disappear if you select a setting that is invalid or out of the allowable range for that parameter, such as trying to set the 24-hour clock to 25:00:00 or a range to less than 1 or more than 20000 ppb. Once you adjust the setting to an allowable value, the ENTR button will re-appear.
Why is the ZERO or SPAN button deactivated during calibration?	This happens when the measured gas concentration differs significantly from the span or zero gas concentration value entered by the user. This prevents accidental recalibration of the analyzer to an out-of-range response curve. EXAMPLE: The span set point is 400 ppb but gas concentration being measured is only 50 ppb.
How do I enter or change the value of my Span Gas?	See Section 4.5.1.2.
Can I automate the calibration of my analyzer?	Any analyzer with zero/span valve or IZS option can be automatically calibrated using the instrument's AutoCal feature (Section 4.6).
Can I use the IZS option to calibrate the analyzer?	Yes. However, the accuracy of the IZS option's permeation tube is only $\pm 5\%$. To achieve highest accuracy, it is recommended to use cylinders of calibrated span gases in combination with a zero air source.
How do I measure the sample flow?	For accurate measurement, attach a calibrated, volumetric flow meter to the sample inlet port, and get a reading while the instrument is operating. The sample flow should be as specified in Table 1-1. (To calibrate, use the Utilities>Diagnostics menu; refer to Section 5.6.6.3).
How often do I need to change the particulate filter?	Refer to the Maintenance Schedule in Table 5-1. Keep in mind that highly polluted sample air may require more frequent changes.
How long does the sample pump last?	The sample pump should last one to two years and the pump head should be replaced when necessary. If the reaction cell pressure value goes above 10 in-Hg-A, on average, the pump head needs to be rebuilt.
Why does my RS-232 serial connection not work?	There are several possible reasons: <ul style="list-style-type: none"> • The wrong cable: please use the provided or a generic "straight-through" cable (do not use a "null-modem" type cable) and ensure the pin assignments are correct (Section 2.3.1.7 under RS-232 Connection). • The DCE/DTE switch on the back of the analyzer is not set properly; ensure that both green and red lights are on (Section 3.4). • The baud rate of the analyzer's COM port does not match that of the serial port of your computer/data logger (Table 2-17).
How do I make the instrument's display and my data logger agree?	This most commonly occurs when an independent metering device is used besides the data logger/recorder to determine gas concentration levels while calibrating the analyzer. These disagreements result from the analyzer, the metering device and the data logger having slightly different ground levels. Use the data logger itself as the metering device during calibration procedures.



T100, T100U, T100H

QUESTION	ANSWER
Do the critical flow orifices of my analyzer require regular replacement?	No. The o-rings and the sintered filter associated with them require replacement once a year, but the critical flow orifices do not. See Section 5.6.4 for instructions.
How do I set up and use the contact closures (Control Inputs) on the rear panel of the analyzer?	See Section 2.3.1.5.

5.9 TECHNICAL ASSISTANCE

If this manual and its troubleshooting & service section do not solve your problems, technical assistance may be obtained from:

Teledyne API Technical Support
9970 Carroll Canyon Road
San Diego, California 92131-1106 USA

Toll-free Phone: 800-324-5190
Phone: +1 858-657-9800
Fax: +1 858-657-9816
Email: api-techsupport@teledyne.com
Website: <http://www.teledyne-api.com/>



6 PRINCIPLES OF OPERATION

This section describes the principles of operation for the SO₂ analyzer and its two optional gas sensors, as well as its electronic and software operation.

6.1 SULFUR DIOXIDE (SO₂) SENSOR PRINCIPLES OF OPERATION

The T100/T100U/T100H UV Fluorescence SO₂ Analyzer is a microprocessor controlled analyzer that determines the concentration of sulfur dioxide (SO₂), in a sample gas drawn through the instrument. It requires that sample and calibration gases be supplied at ambient atmospheric pressure in order to establish a constant gas flow through the sample chamber where the sample gas is exposed to ultraviolet light; this exposure causes the SO₂ molecules to change to an excited state (SO₂*). As these SO₂* molecules decay into SO₂ they fluoresce. The instrument measures the amount of fluorescence to determine the amount of SO₂ present in the sample gas.

Calibration of the instrument is performed in software and usually does not require physical adjustments to the instrument. During calibration, the microprocessor measures the sensor output signal when gases with known amounts of SO₂ at various concentrations are supplied and stores these measurements in memory. The microprocessor uses these calibration values along with other performance parameters such as the PMT dark offset, UV lamp ratio and the amount of stray light present and measurements of the temperature and pressure of the sample gas to compute the final SO₂ concentration.

This concentration value and the original information from which it was calculated are stored in the unit's internal data acquisition system and reported to the user through a vacuum fluorescent display or as electronic data via several communication ports.

This concentration value and the original information from which it was calculated are stored in the unit's internal data acquisition system (DAS), the Data Logger, and reported to the user through a vacuum fluorescent display or several communication ports.

6.1.1 SO₂ ULTRAVIOLET FLUORESCENCE MEASUREMENT PRINCIPLE

The physical principle upon which the T100's measurement method is based is the fluorescence that occurs when sulfur dioxide (SO₂) is changed to excited state (SO₂*) by ultraviolet light with wavelengths in the range of 190 nm-230 nm. This reaction is a two-step process.

The first stage (Equation 6-1) occurs when SO₂ molecules are struck by photons of the appropriate ultraviolet wavelength. In the case of the T100, a band pass filter between the source of the UV light and the affected gas limits the wavelength of the light to approximately 214 nm. The SO₂ absorbs some of energy from the UV light causing one of the electrons of the SO₂ molecule to move to a higher energy orbital state.

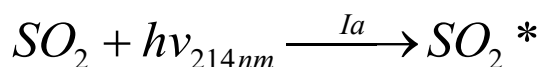

(Equation 6-1)



T100, T100U, T100H

The amount SO_2 converted to SO_2^* in the sample chamber is dependent on the average intensity of the UV light (I_a) and not its peak intensity because the intensity of UV light is not constant in every part of the sample chamber. Some of the photons are absorbed by the SO_2 as the light travels through the sample gas.

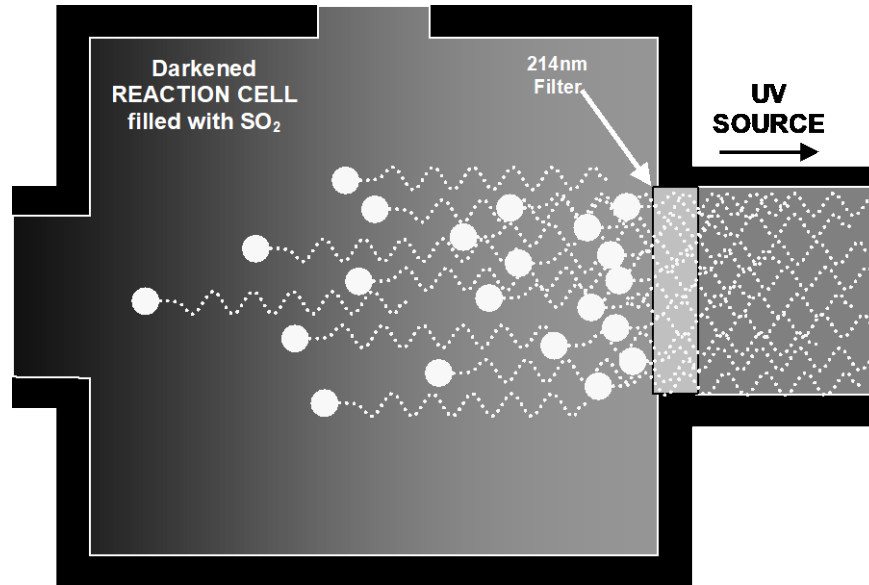

Figure 6-1. UV Absorption

The equation for defining the average intensity of the UV light (I_a) is:

$$I_a = I_0 [1 - \exp(-ax(SO_2))]$$

(Equation 6-2)

Where:

I_0 = Intensity of the excitation UV light.

a = The absorption coefficient of SO_2 (a constant).

SO_2 = Concentration of SO_2 in the sample chamber.

x = The distance between the UV source and the SO_2 molecule(s) being affected (path length).

The second stage of this reaction occurs after the SO_2 reaches its excited state (SO_2^*). Because the system will seek the lowest available stable energy state, the SO_2^* molecule quickly returns to its ground state (Equation 6-3) by giving off the excess energy in the form of a photon ($h\nu$). The wavelength of this fluoresced light is also in the ultraviolet band but at a longer (lower energy) wavelength centered at 330nm.



T100, T100U, T100H

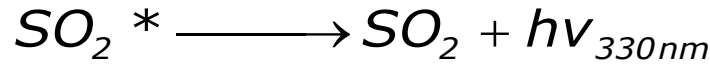

(Equation 6-3)

The amount of detectable UV given off by the decay of the SO_2^* is affected by the rate at which this reaction occurs (k).

$$F = k(SO_2^*)$$

(Equation 6-4)

Where:

F = the amount of fluorescent light given off.

k = the rate at which the SO_2^* (excited state) decays into SO_2 .

SO_2^* = Amount of excited-state SO_2 in the sample chamber.

Therefore:

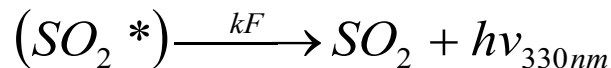

(Equation 6-5)

Finally, the function (k) is affected by the temperature of the gas. The warmer the gas, the faster the individual molecules decay back into their ground state and the more photons of UV light are given off per unit of time.

Given that the absorption rate of SO_2 (a) is constant, the amount of fluorescence (F) is a result of:

- The amount of SO_2^* created which is affected by the variable factors from (Equation 6-2) above; concentration of SO_2 ; intensity of UV light (I_0); path length of the UV light (x), and
- The amount of fluorescent light created which is affected by the variable factors from (Equation 6-5); the amount of SO_2^* present and the rate of decay (k) which changes based on the temperature of the gas.

When and the intensity of the light (I_0) is known; path length of excited light is short (x); the temperature of the gas is known and compensated for so that the rate of SO_2^* decay is constant (k). and; no interfering conditions are present (such as interfering gases or stray light); the amount of fluorescent light emitted (F) is directly related to the concentration of the SO_2 in the Sample Chamber.



T100, T100U, T100H

The Model T100 UV Fluorescence SO₂ Analyzer is specifically designed to create these circumstances.

- The light path is very short (x).
- A reference detector measures the intensity of the available excitation UV light and is used to remove effects of lamp drift (I_0).
- The temperature of the sample gas is measured and controlled via heaters attached to the sample chamber so that the rate of decay (k) is constant.
- A special hydrocarbon scrubber removes the most common interfering gases from the sample gas.
- And finally, the design of the sample chamber reduces the effects of stray light via its optical geometry and spectral filtering.

The net result is that any variation in UV fluorescence can be directly attributed to changes in the concentration of SO₂ in the sample gas.

6.1.2 THE UV LIGHT PATH

The optical design of the sample chamber optimizes the fluorescent reaction between SO₂ and UV Light (refer to Figure 6-2) and assures that only UV light resulting from the decay of SO₂* into SO₂ is sensed by the instrument's fluorescence detector.

UV radiation is generated by a lamp specifically designed to produce a maximum amount of light of the wavelength needed to excite SO₂ into SO₂* (214 nm) and a special reference detector circuit constantly measures lamp intensity (refer to (Equation 6-2)). A Photo Multiplier Tube (PMT) detects the UV given off by the SO₂* decay (330 nm) and outputs an analog signal. Several focusing lenses and optical filters ensure that both detectors are exposed to an optimum amount of only the right wavelengths of UV. To further assure that the PMT only detects light given off by decaying SO₂* the pathway of the excitation UV and field of view of the PMT are perpendicular to each other and the inside surfaces of the sample chamber are coated with a layer of black Teflon[®] that absorbs stray light.



T100, T100U, T100H

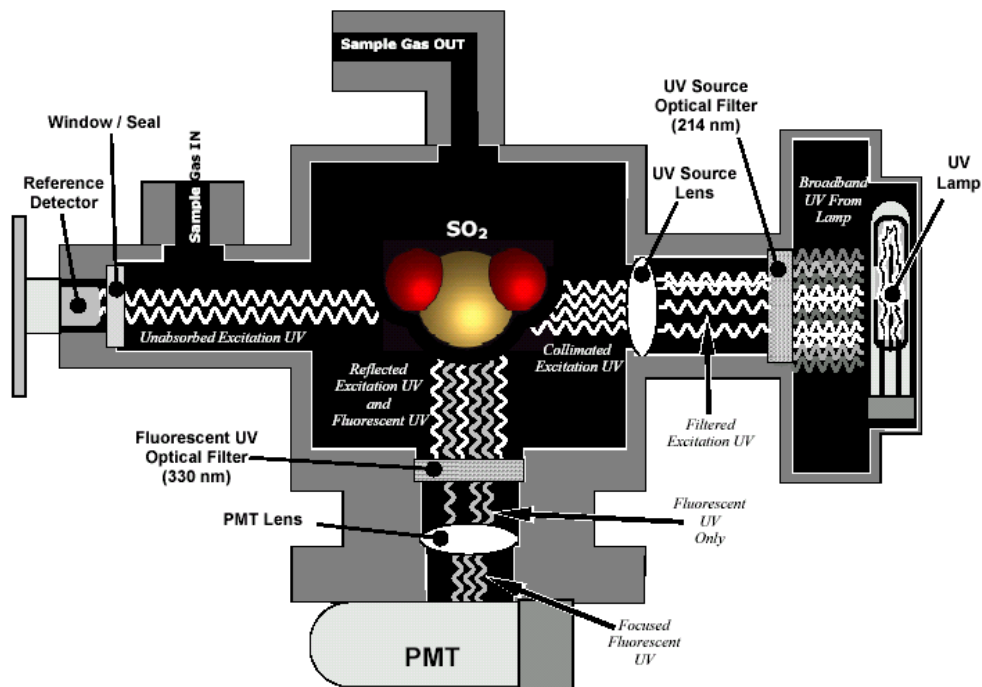

Figure 6-2. T100, T100U UV Light Path

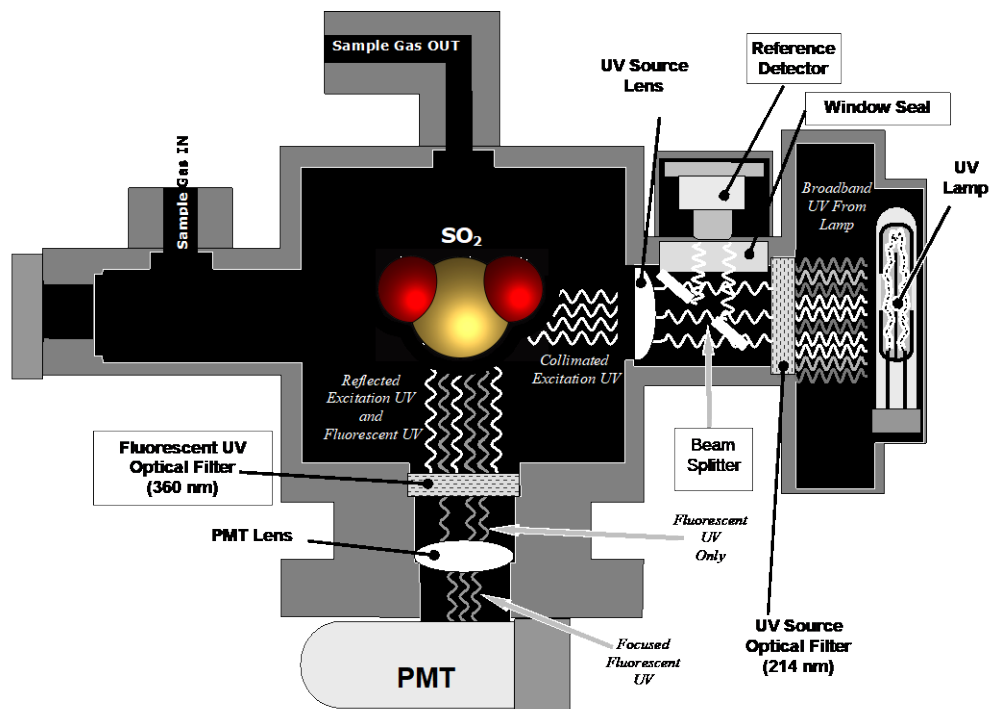

Figure 6-3. T100H UV Light Path



6.1.3 UV SOURCE LAMP

The source of excitation UV light for the T100 is a low pressure zinc-vapor lamp. A DC voltage heats up and vaporizes zinc contained in the lamp element creating a light-producing plasma arc. Zinc-vapor lamps are preferred over the more common mercury-vapor lamps for this application because they produce very strong emission levels at the wavelength required to convert SO_2 to SO_2^* , 213.9 nm (refer to Figure 6-5).

The lamp used in the T100 is constructed with a vacuum jacket surrounding a double-bore lamp element (refer to Figure 6-4). The vacuum jacket isolates the plasma arc from most external temperature fluctuations. The jacket also contains thermal energy created by the lamp's operation therefore helping the lamp to heat up and maintain proper vaporization temperature. Light is emitted through a 20 mm x 5 mm portal.

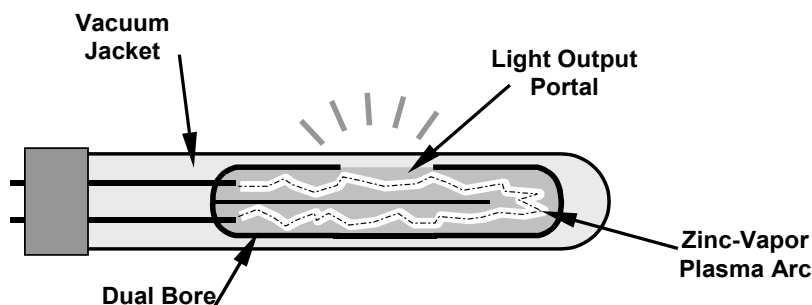

Figure 6-4. Source UV Lamp Construction

6.1.4 THE REFERENCE DETECTOR

A vacuum diode, UV detector that converts UV light to a DC current is used to measure the intensity of the excitation UV source lamp. In the T100 and T100U it is located directly across from the source lamp at the back of a narrow tube-shaped light trap, which places it directly in the path of the excitation UV light (Figure 6-2). In the T100H it is located between the UV lamp and the reaction cell, and to the side. A beam splitter reflects a portion of the lamp output 90 degrees through a window and onto the detector (Figure 6-3). A window transparent to UV light provides an air-proof seal that prevents ambient gas from contaminating the sample chamber. Due to the shape of the light trap and the fact that the detector is blind to wavelengths other than UV, no extra optical filtering is needed.

6.1.5 THE PMT

The amount of fluoresced UV produced in the sample chamber is much less than the intensity of excitation UV source lamp (refer to Figure 6-5). Therefore a much more sensitive device is needed to detect this light with enough resolution to be meaningful. The Photo Multiplier Tube (PMT) serves this purpose.

A PMT is typically a vacuum tube containing a variety of specially designed electrodes. Photons enter the PMT and strike a negatively charged photo cathode causing it to emit electrons. These electrons are accelerated by a high voltage applied across a series of special electrodes called dynodes that multiply the amount of electrons until a useable current signal is generated. This current increases or decreases with the amount of detected light.



6.1.6 UV LAMP SHUTTER & PMT OFFSET

Inherent in the operation of both the reference detector and the PMT are a minor electronic offsets. The degree of offset differs from detector to detector and from PMT to PMT and can change as these components age.

To account for these offsets the analyzer includes a shutter, located between the UV Lamp and the source filter that periodically cuts off the UV light from the sample chamber. This happens every 30 minutes. The analyzer records the outputs of both the reference detector and the PMT during this dark period and factors them into the SO₂ concentration calculation.

- The reference detector offset is stored as **Dark Lamp** and can be viewed in the Dashboard.
- The PMT offset is stored as **Dark PMT** and can be viewed in the Dashboard.

6.1.7 OPTICAL FILTERS

The analyzer uses two stages of optical filters to enhance performance. The first stage conditions the UV light used to excite the SO₂ by removing frequencies of light that are not needed to produce SO₂*. The second stage protects the PMT detector from reacting to light not produced by the SO₂* returning to its ground state.

6.1.7.1 UV SOURCE OPTICAL FILTER

Zinc-vapor lamps output light at other wavelengths beside the 214nm required for the SO₂ → SO₂* transformation including a relatively bright light of the same wavelength at which SO₂* fluoresces as it returns to its SO₂ ground state (330 nm). In fact, the intensity of light emitted by the UV lamp at 330nm is so bright, nearly five orders of magnitude brighter than that resulting from the SO₂* decay, it would drown out the SO₂* fluorescence.

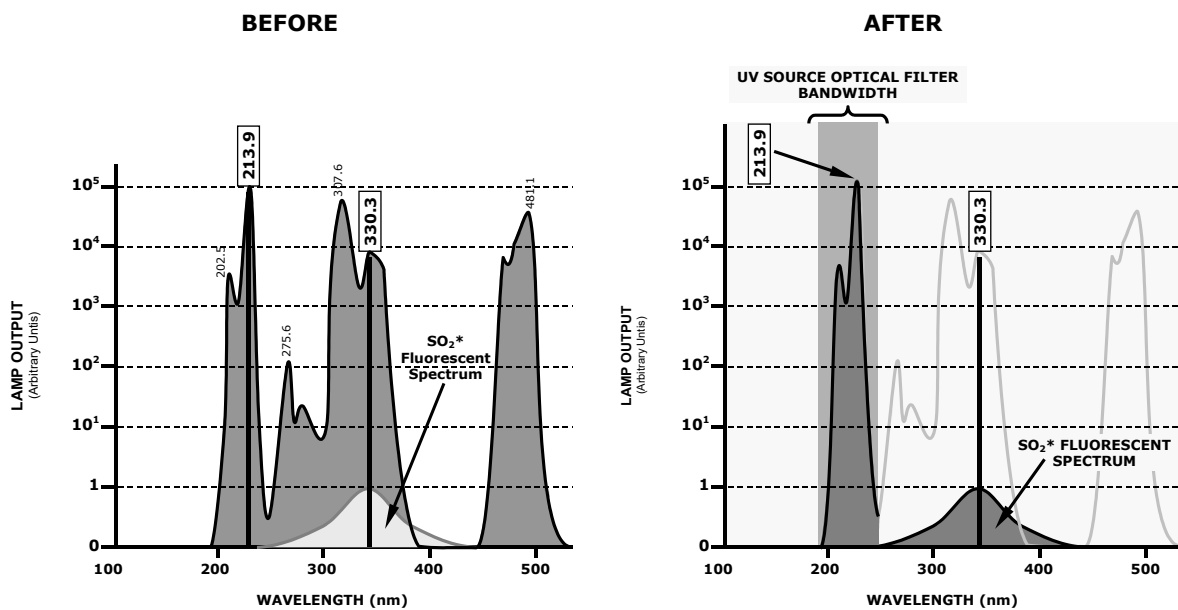

Figure 6-5. Excitation Lamp UV Spectrum Before/After Filtration



T100, T100U, T100H

To solve this problem, the light emitted by the excitation UV lamp passes through a band pass filter that screens out photons with wavelengths outside the spectrum required to excite SO_2 into SO_2^* (refer to Figure 6-5).

6.1.7.2 PMT OPTICAL FILTER

The PMT reacts to a wide spectrum of light which includes much of the visible spectrum and most of the UV spectrum. Even though the 214 nm light used to excite the SO_2 is focused away from the PMT, some of it scatters in the direction of the PMT as it interacts with the sample gas. A second optical band pass filter placed between the sample chamber (refer to Figure 6-2) and the PMT strips away light outside of the fluorescence spectrum of decaying SO_2^* (refer to Figure 6-6) including reflected UV from the source lamp and other stray light.

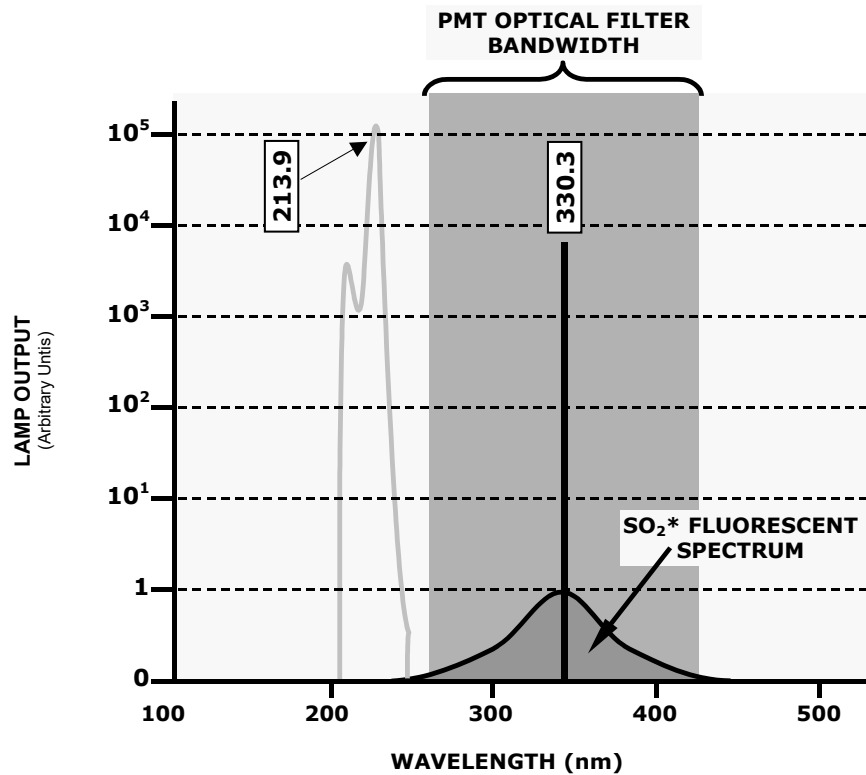

Figure 6-6. PMT Optical Filter Bandwidth



6.1.8 OPTICAL LENSES

Two optical lenses are used to focus and optimize the path of light through the sample chamber.

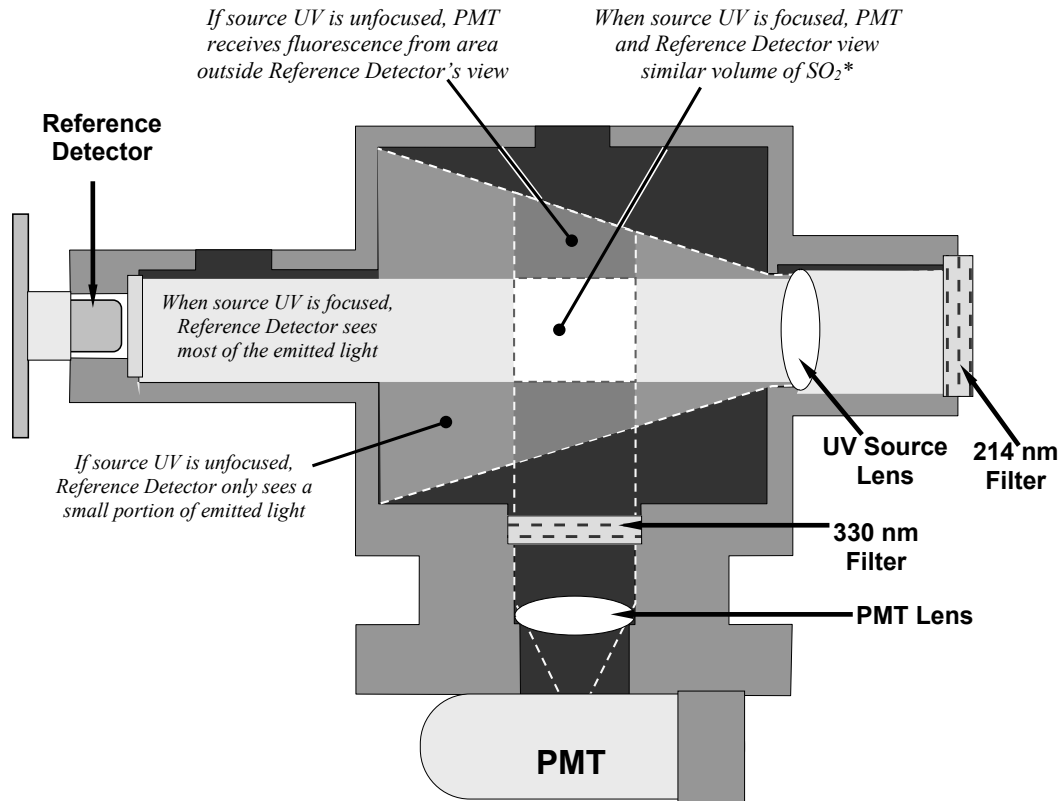

Figure 6-7. Effects of Focusing Source UV in Sample Chamber

A lens located between PMT and the sample chamber collects as much of the fluoresced UV created there as possible and focuses it on the most sensitive part of the PMT's photo cathode.

Another lens located between the excitation UV source lamp and the sample chamber collimates the light emitted by the lamp into a steady, circular beam and focuses that beam directly onto the reference detector. This allows the reference detector to accurately measure the effective intensity of the excitation UV by eliminating the effect of flickering inherent in the plasma arc that generates the light.

This ensures that all of the light emitted by the source lamp passes through the 214 nm filter and is not absorbed by the SO₂ that reaches the reference detector. Conversely, this also ensures that the volume of sample gas affected by the excitation beam is similar to the volume of fluorescing SO₂* being measured by the PMT, eliminating a possible source of measurement offset.



6.1.9 MEASUREMENT INTERFERENCES

It should be noted that the fluorescence method for detecting SO₂ is subject to interference from a number of sources. The T100/U/H has been successfully tested for its ability to reject interference from most of these sources.

6.1.9.1 DIRECT INTERFERENCE

The most common source of interference is from other gases that fluoresce in a similar fashion to SO₂ when exposed to UV Light. The most significant of these is a class of hydrocarbons called poly-nuclear aromatics (PNA) of which xylene and naphthalene are two prominent examples. Nitrogen oxide (NO) fluoresces in a spectral range near to SO₂. For critical applications where high levels of NO are expected, an optional optical filter is available for the T100 and T100U that improves the rejection of NO (contact Technical Support for more information). However, the standard T100H has that optical filter in place due to its typical application that often includes much higher concentrations of NO. The Analyzer has several methods for rejecting interference from these gases:

- A special scrubber (kicker) mechanism removes any PNA chemicals present in the sample gas before it reaches the sample chamber. This hydrocarbon scrubber is standard in the T100 and T100U, and is an option for the T100H since its typical application rarely includes the presence of PNAs.
- The exact wavelength of light needed to excite a specific non-SO₂ fluorescing gas is removed by the source UV optical filter.
- The light given off by Nitrogen Oxide and many of the other fluorescing gases is outside of the bandwidth passed by the PMT optical filter.

6.1.9.2 UV ABSORPTION BY OZONE

Because ozone absorbs UV Light over a relatively broad spectrum, it could cause a measurement offset by absorbing some of the UV given off by the decaying SO₂* in the sample chamber. The analyzer prevents this from occurring by having a very short light path between the area where the SO₂* fluorescence occurs and the PMT detector. Because the light path is so short, the amount of O₃ needed to cause a noticeable effect would be much higher than could be reasonably expected in any application for which this instrument is intended.

6.1.9.3 DILUTION

Certain gases with higher viscosities can lower the flow rate through the critical flow orifice that controls the movement of sample gas through the analyzer reducing the amount of sample gas in the sample chamber and thus the amount of SO₂ available to react with the UV light. While this can be a significant problem for some analyzers, the design of the analyzer is very tolerant of variations in sample gas flow rate and therefore does not suffer from this type of interference.

6.1.9.4 THIRD BODY QUENCHING

While the decay of SO₂* to SO₂ happens quickly, it is not instantaneous. Because it is not instantaneous it is possible for the extra energy possessed by the excited electron of the SO₂* molecule to be given off as kinetic energy during a collision with another molecule.



T100, T100U, T100H

This in effect heats the other molecule slightly and allows the excited electron to move into a lower energy orbit without emitting a photon.

The most significant interferents in this regard are nitrogen oxide (NO), carbon dioxide (CO₂), water vapor (H₂O) and molecular oxygen (O₂). In ambient applications the quenching effect of these gases is negligible. For stack applications where the concentrations of some or all of these may be very high, specific steps **MUST** be taken to remove them from the sample gas before it enters the analyzer.

6.1.9.5 LIGHT POLLUTION

Because the analyzer measures light as a means of calculating the amount of SO₂ present, obviously stray light can be a significant interfering factor. The analyzer removes this interference source in several ways.

- The sample chamber is designed to be completely light tight to light from sources other than the excitation UV source lamp.
- All pneumatic tubing leading into the sample chamber is completely opaque in order to prevent light from being piped into the chamber by the tubing walls.
- The optical filters discussed in Section 6.1.7; remove UV with wavelengths extraneous to the excitation and decay of SO₂/SO₂*.
- Most importantly, during instrument calibration the difference between the value of the most recently recorded PMT offset (refer to Section 6.1.6) and the PMT output while measuring zero gas (calibration gas devoid of SO₂) is recorded as the test function **OFFSET**. This **OFFSET** value is used during the calculation of the SO₂ concentration.

Since this offset is assumed to be due to stray light present in the sample chamber, it is also multiplied by the **SLOPE** and recorded as the function **Stray Light**.

6.2 OXYGEN (O₂) SENSOR PRINCIPLES OF OPERATION

The O₂ sensor applies paramagnetics to determine the concentration of oxygen in a sample gas drawn through the instrument.

6.2.1 PARAMAGNETIC MEASUREMENT OF O₂

The oxygen sensor used in the analyzer utilizes the fact that oxygen is attracted into strong magnetic field while most other gases are not, to obtain fast, accurate oxygen measurements.

The sensor's core is made up of two nitrogen filled glass spheres, which are mounted on a rotating suspension within a magnetic field (refer to Figure 6-8). A mirror is mounted centrally on the suspension and light is shone onto the mirror that reflects the light onto a pair of photocells. The signal generated by the photocells is passed to a feedback loop, which outputs a current to a wire winding (in effect, a small DC electric motor) mounted on the suspended mirror.

Oxygen from the sample stream is attracted into the magnetic field displacing the nitrogen filled spheres and causing the suspended mirror to rotate. Therefore, the amount of light reflected onto the photocells and therefore the output levels of the photocells. The feedback loop increases the amount of current fed into the winding in order to move the mirror back



T100, T100U, T100H

into its original position. The more O_2 present, the more the mirror moves and the more current is fed into the winding by the feedback control loop.

A sensor measures the amount of current generated by the feedback control loop which is directly proportional to the concentration of oxygen within the sample gas mixture.

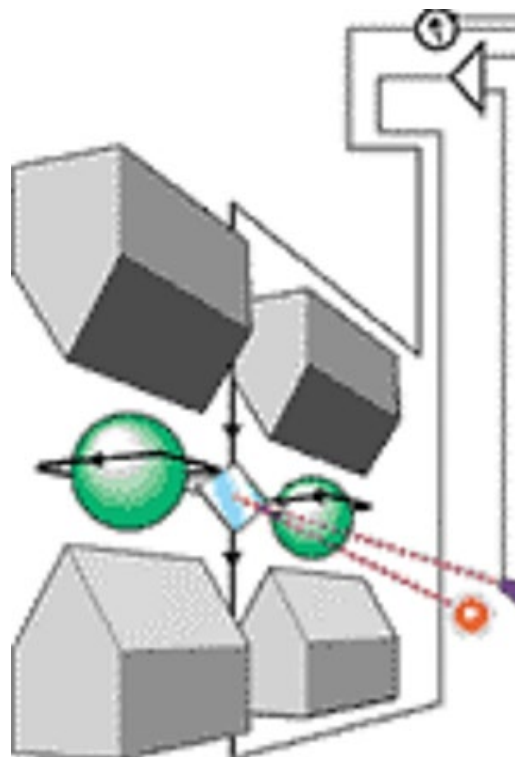

Figure 6-8. Oxygen Sensor - Principles of Operation

6.2.2

O_2 SENSOR OPERATION WITHIN THE T100 ANALYZER

The oxygen sensor option is transparently integrated into the core analyzer operation. All functions can be viewed or accessed through the front panel display, just like the functions for SO_2 .

The O_2 concentration range is 0-100% (user selectable) with 0.1% precision and accuracy.

The temperature of the O_2 sensor is maintained at a constant 50°C by means of a PID loop.

The O_2 sensor assembly itself does not have any serviceable parts and is enclosed in an insulated canister.



6.3 CARBON DIOXIDE (CO₂) SENSOR PRINCIPLES OF OPERATION

The CO₂ sensor probe measures the concentration of carbon dioxide in the sample gas; a Logic PCA conditions the probe output and issues a 0-5 VDC signal to the analyzer's CPU, which computes the CO₂ concentration by scaling the values of the **CO₂ SLOPE** and **CO₂ OFFSET** recorded during calibration

The CO₂ sensor assembly itself does not have any serviceable parts and is enclosed in an insulated canister.

6.3.1 NDIR MEASUREMENT OF CO₂

The optional CO₂ sensor is a silicon based Non-Dispersive Infrared (NDIR) sensor. It uses a single-beam, dual wavelength measurement method.

An infrared source at one end of the measurement chamber emits IR radiation into the sensor's measurement chamber where light at the 4.3 μm wavelength is partially absorbed by any CO₂ present. A special light filter called a Fabry-Perot Interferometer (FPI) is electronically tuned so that only light at the absorption wavelength of CO₂ is allowed to pass and be detected by the sensor's IR detector.

A reference measurement is made by electronically shifting the filter band pass wavelength so that no IR at the CO₂ absorption wavelength is let through.

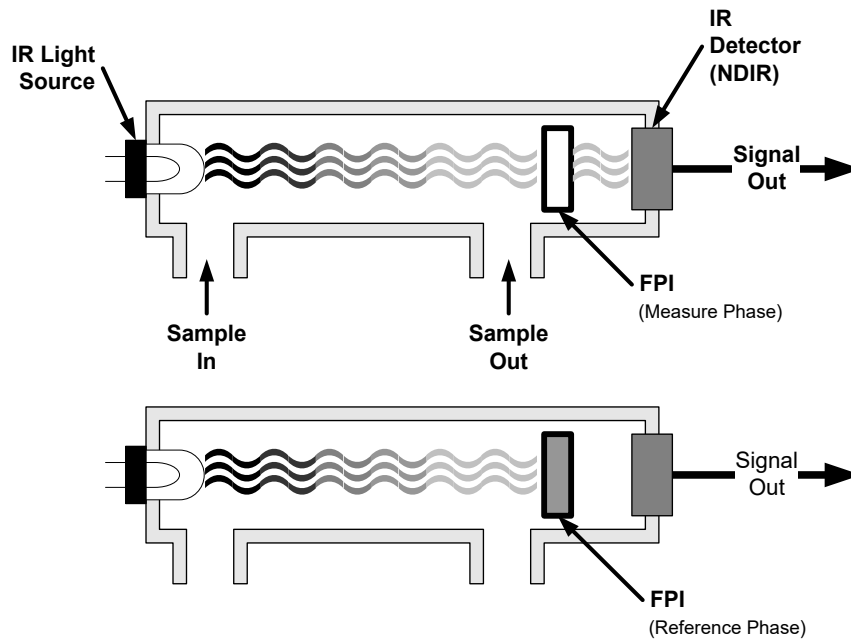

Figure 6-9. CO₂ Sensor Principles of Operation

The sensor computes the ratio between the reference signal and the measurement signal to determine the degree of light absorbed by CO₂ present in the sensor chamber. This dual wavelength method the CO₂ measurement allows the instrument to compensate for ancillary effects like sensor aging and contamination.



6.4 PNEUMATIC OPERATION

Important

IMPACT ON READINGS OR DATA

It is important that the sample airflow system is leak-tight and not pressurized over ambient pressure. Regular leak checks should be performed on the analyzer as stated in the Maintenance Schedule.

Note

Relative Pressure vs Absolute Pressure: In this manual vacuum readings are given in inches of mercury absolute pressure (in-Hg-A), i.e. indicate an absolute pressure referenced against zero (a perfect vacuum).

6.4.1 SAMPLE GAS FLOW

The flow of gas through the instrument is created by a small internal pump in the T100 and the T100U, and an external pump for the T100H. that pulls air though the instrument.

6.4.2 FLOW RATE CONTROL

The analyzer uses a special flow control assembly (refer to Figure 6-11, Figure 6-12, and Figure 6-13) to maintain a constant flow rate of the sample gas through the instrument. This assembly consists of:

- A critical flow orifice.
- Two o-rings: Located just before and after the critical flow orifice, the o-rings seal the gap between the walls of assembly housing and the critical flow orifice.
- A spring: Applies mechanical force needed to form the seal between the o-rings, the critical flow orifice and the assembly housing.

6.4.2.1 CRITICAL FLOW ORIFICE

The most important component of this flow control assembly is the critical flow orifice.

Critical flow orifices are a simple way to regulate stable gas flow rates. They operate without moving parts by taking advantage of the laws of fluid dynamics. Restricting the flow of gas through the orifice creates a pressure differential. This pressure differential combined with the action of the analyzer's pump draws the gas through the orifice.

As the pressure on the downstream side of the orifice (the pump side) continues to drop, the speed that the gas flows through the orifice continues to rise. Once the ratio of upstream pressure to downstream pressure is greater than 2:1, the velocity of the gas through the orifice reaches the speed of sound. As long as that ratio stays at least 2:1 the gas flow rate is unaffected by any fluctuations, surges, or changes in downstream pressure because such variations only travel at the speed of sound themselves and are therefore cancelled out by the sonic shockwave at the downstream exit of the critical flow orifice.

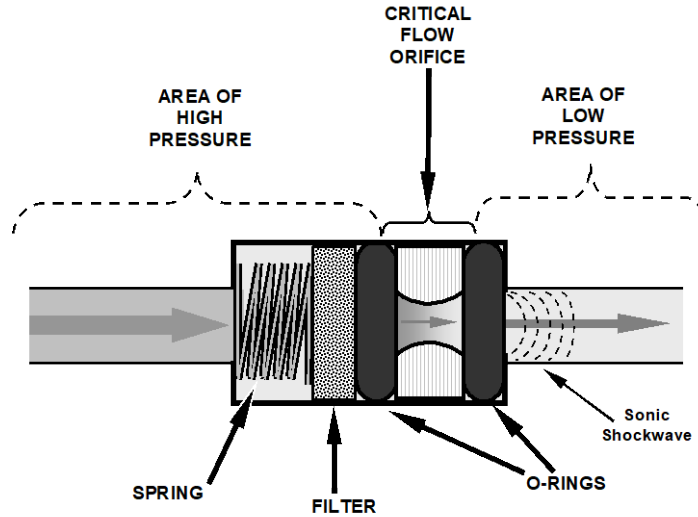

Figure 6-11. Flow Control Assembly & Critical Flow Orifice

The actual flow rate of gas through the orifice (volume of gas per unit of time), depends on the size and shape of the aperture in the orifice (refer to the specifications for your model in Table 1-1). The larger the hole, the more gas molecules, moving at the speed of sound, pass through the orifice. Because the flow rate of gas through the orifice is only related to the minimum 2:1 pressure differential and not absolute pressure the flow rate of the gas is also unaffected by degradations in pump efficiency due to age.

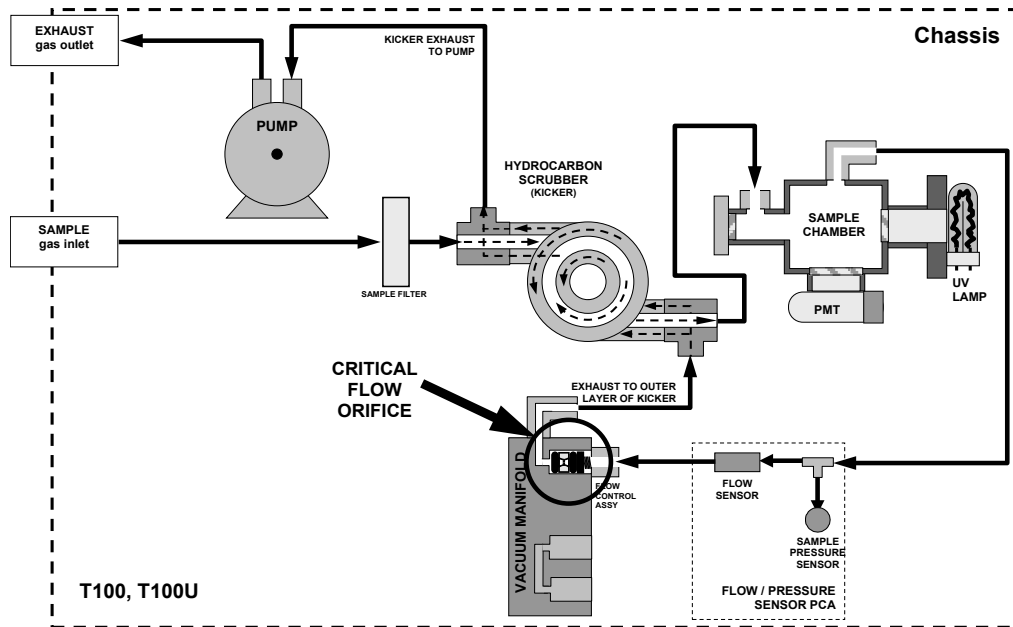

Figure 6-12. Location of Critical Flow Orifice in T100, T100U



T100, T100U, T100H

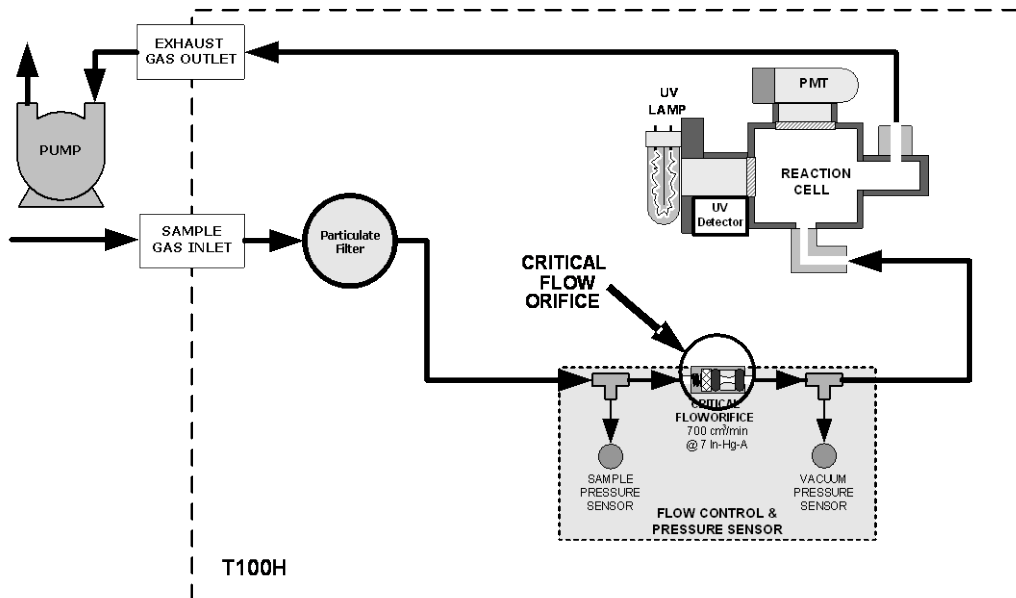

Figure 6-13. Location of Critical Flow Orifice in T100H

6.4.2.2 SAMPLE PARTICULATE FILTER

To remove particles in the sample gas, the analyzer is equipped with a Teflon membrane filter of 47 mm diameter (also referred to as the sample filter) with a 1 μm or 5 μm pore size. The filter is accessible through the front panel, which folds down, and should be changed according to the Maintenance Schedule.

6.4.3 HYDROCARBON SCRUBBER (KICKER)

It is very important to ensure that the air supplied sample chamber is clear of hydrocarbons. To accomplish this task the analyzer uses a single tube permeation scrubber (an option in the T100H for which this is not an issue for its typical application). The scrubber consists of a single tube of a specialized plastic that absorbs hydrocarbons very well. This tube is located within outer flexible plastic tube shell. As gas flows through the inner tube, hydrocarbons are absorbed into the membrane walls and transported through the membrane wall and into the hydrocarbon free, purge gas flowing through the outer tube. This process is driven by the hydrocarbon concentration gradient between the inner and outer of the tubes.



T100, T100U, T100H

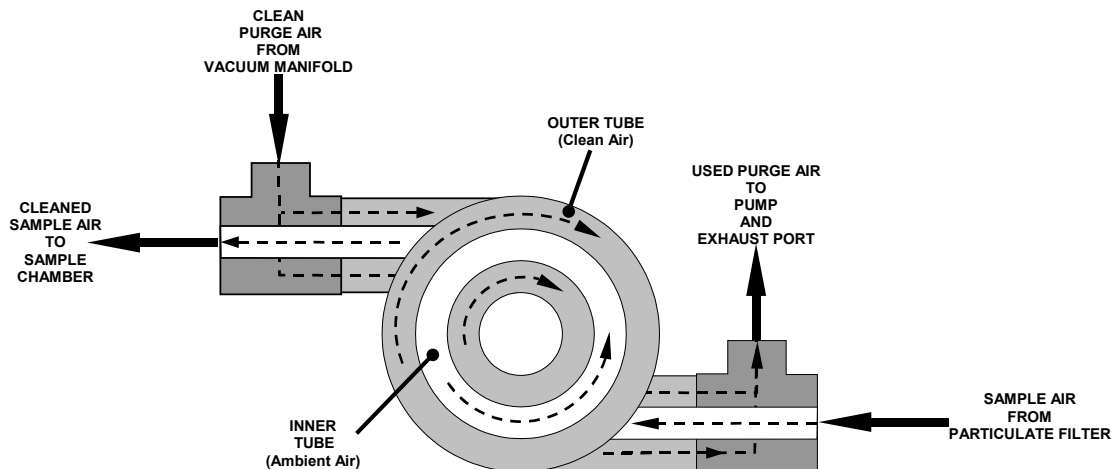

Figure 6-14. Hydrocarbon Scrubber (Kicker)

Some of the cleaned air from the inner tube is returned to be used as the purge gas in the outer tube (refer to Figure 6-14). This means that when the analyzer is first started, the concentration gradient between the inner and outer tubes is not very large and the scrubber's efficiency is relatively low. When the instrument is turned on after having been off for more than 30 minutes, it takes a certain amount of time for the gradient to become large enough for the scrubber to adequately remove hydrocarbons from the sample air.

6.4.4 PNEUMATIC SENSORS

The analyzer uses two pneumatic sensors to verify gas streams. These sensors are located on a printed circuit assembly, called the pneumatic pressure/flow sensor board. The flow simultaneously enters the sample pressure sensor and the flow sensor from the outlet of the reaction cell.

6.4.4.1 SAMPLE PRESSURE SENSOR

An absolute pressure transducer plumbed to the input of the analyzer's sample chamber is used to measure the pressure of the sample gas before it enters the chamber. This upstream measurement is used to validate the critical flow condition (2:1 pressure ratio) through the instrument's critical flow orifice (refer to Section 6.4.2). Also, if the Temperature/Pressure Compensation (TPC) feature is turned on, the output of this sensor is also used to supply pressure data for that calculation.

The actual pressure measurement is viewable in the Dashboard as **Pressure**.

6.4.4.2 SAMPLE FLOW SENSOR

A thermal-mass flow sensor is used to measure the sample flow through the analyzer. This sensor is also mounted on the pneumatic pressure/flow sensor board upstream of the sample chamber. The flow rate is monitored by the CRT which issues an Alert if the flow rate is too high or too low.

The flow rate of the sample gas is viewable in the Dashboard as Sample Flow.

6.5 ELECTRONIC OPERATION

6.5.1 OVERVIEW

Figure 6-15 shows a block diagram of the major electronic components of the analyzer.

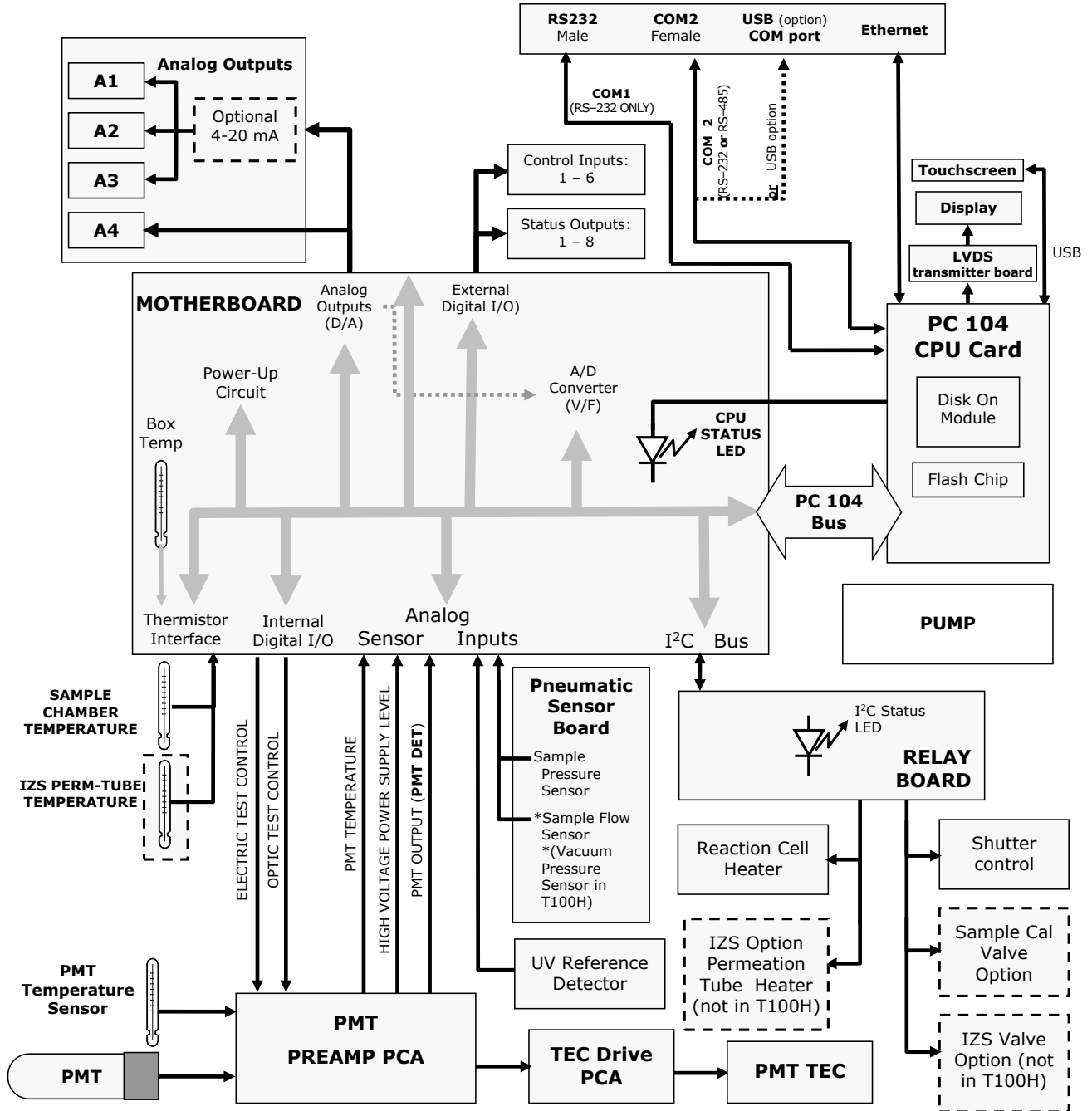

Figure 6-15. Electronic Block Diagram



T100, T100U, T100H

The core of the analyzer is a microcomputer/central processing unit (CPU) that controls various internal processes, interprets data, makes calculations, and reports results using specialized firmware developed by Teledyne API. It communicates with the user as well as receives data from and issues commands to a variety of peripheral devices via a separate printed circuit assembly onto which the CPU is mounted: the motherboard.

The motherboard is directly mounted to the inside rear panel and collects data, performs signal conditioning duties and routes incoming and outgoing signals between the CPU and the analyzer's other major components.

Concentration data are generated by the Photo Multiplier Tube (PMT), which produces an analog current signal corresponding to the brightness of the fluorescence reaction in the sample chamber. This current signal is amplified to a DC voltage signal (Dashboard parameter **PMT**) by a PMT preamplifier printed circuit assembly (located on top of the sensor housing). **PMT** is converted to digital data by a bi-polar, analog-to-digital converter, located on the motherboard.

In addition to the PMT signal, a variety of sensors report the physical and operational status of the analyzer's major components, again through the signal processing capabilities of the motherboard. These status reports are used as data for the SO₂ concentration calculation (e.g. pressure and temperature reading used by the temperature/pressure compensation feature) and as trigger events for certain warning messages and control commands issued by the CPU. They are stored in the CPU's memory and, in most cases, can be viewed through the front panel display.

The CPU communicates with the user and the outside world in a variety of ways:

- Through the analyzer's front panel LCD touch-screen interface
- RS-232 and RS-485 serial I/O channels
- Various analog voltage and current outputs
- Several digital I/O channels
- Ethernet

Finally, the CPU issues commands (also over the I²C bus) to a series of relays and switches located on a separate printed circuit assembly, the relay board (located in the rear of the chassis on its own mounting bracket) to control the function of key electromechanical devices such as valves and heaters.



6.5.2 CPU

The unit's CPU card, installed on the motherboard located inside the rear panel, is a low power (5 VDC, 720mA max), high performance, Vortex86SX-based microcomputer running Windows CE. Its operation and assembly conform to the PC 104 specification. The CPU includes two types of non-volatile data storage: a Disk-on-Module (DOM) and an embedded flash chip. The DOM is a 44-pin IDE flash drive with storage a 512 MB capacity. It is used to store the computer's operating system, the Teledyne API firmware, and most of the operational data generated by the analyzer's internal data acquisition system (DAS). The non-volatile, embedded flash chip includes 2MB of storage for calibration data as well as a backup of the analyzer configuration.

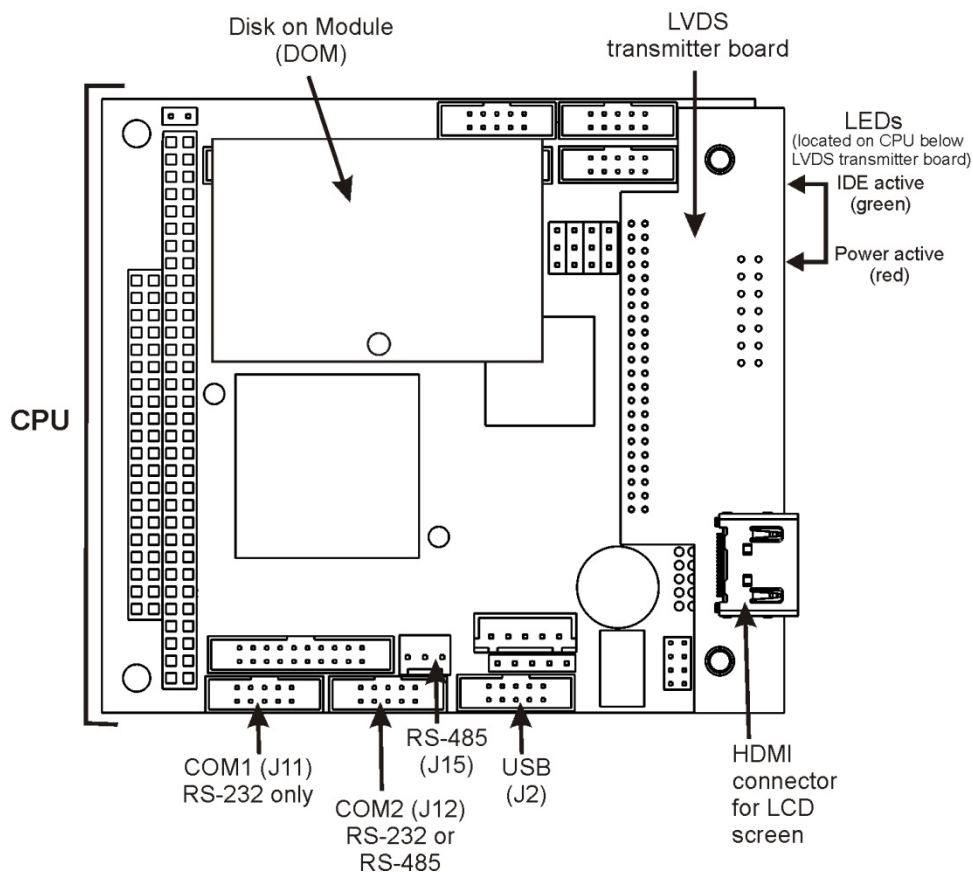

Figure 6-16. CPU Board

6.5.3 SENSOR MODULE

Electronically, the analyzer sensor module components create the UV light that initiates the fluorescence reaction between SO₂ and O₃; sense the intensity of that fluorescence; generate various electronic signals needed by the analyzer to determine the SO₂ concentration of the sample gas, and sense and control key environmental conditions such as the temperature of the sample gas and the photo multiplier tube (PMT).



T100, T100U, T100H

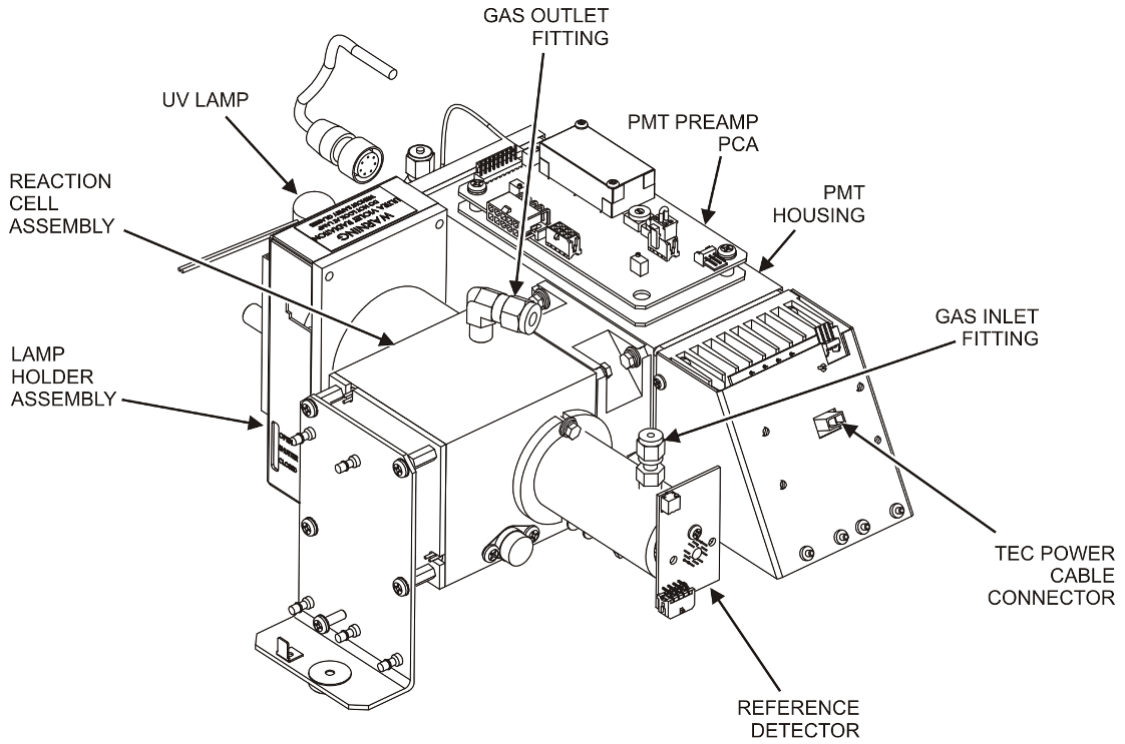

Figure 6-17. T100 Sensor Module

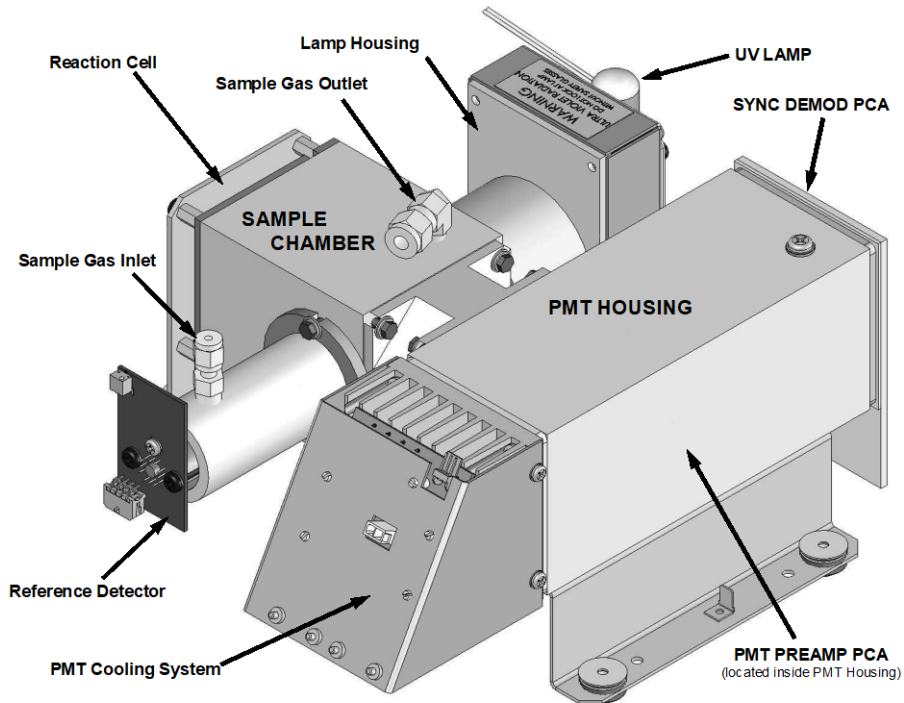

Figure 6-18. T100U Sensor Module



T100, T100U, T100H

These components are divided into two significant subassemblies. The sample chamber and the PMT assembly.

Exploded views of the sample chamber assembly for the T100 and for the T100U are shown in Figure 6-19 and Figure 6-20, respectively.

Exploded views of the PMT assembly for the T100 and for the T100U were shown earlier in Figure 5-25 and Figure 5-26. Sample Chamber

The main electronic components of the T100 sample chamber are the reference detector (refer to Section 6.1.4); the UV Lamp (refer to Section 6.1.3) and its electronically operated shutter (refer to Section 6.1.6); and the sample chamber heating circuit.

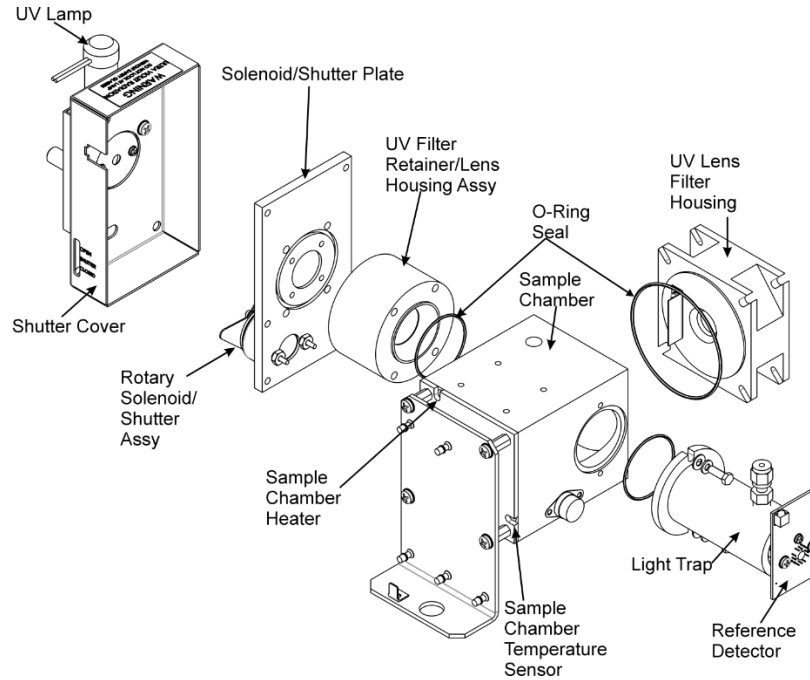

Figure 6-19. T100 Sample Chamber



T100, T100U, T100H

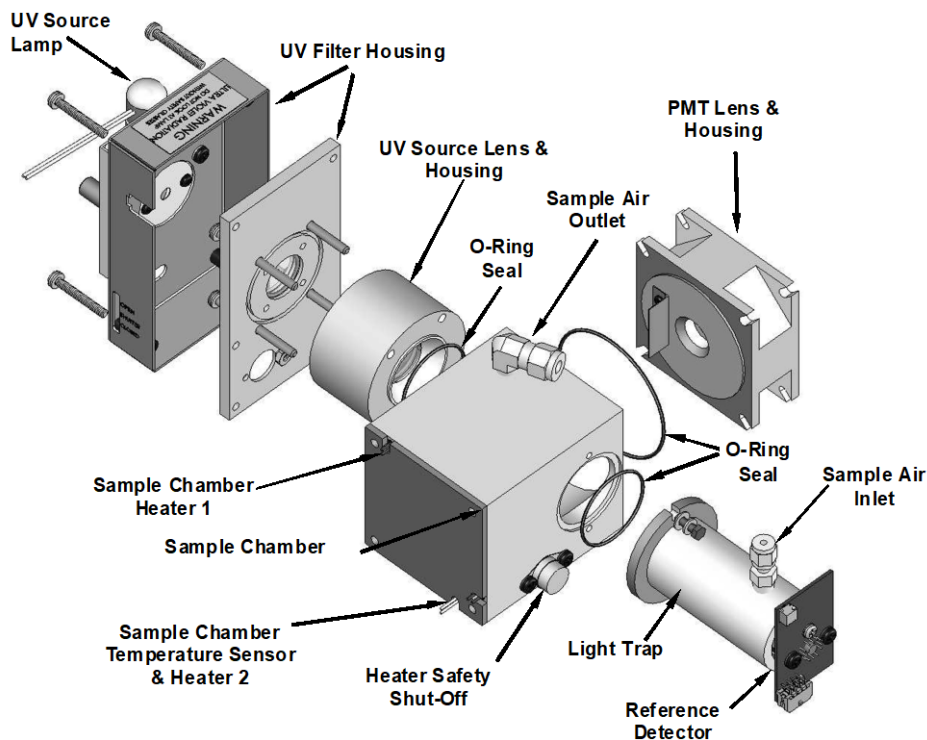

Figure 6-20. T100U Sample Chamber

6.5.3.1 SAMPLE CHAMBER HEATING CIRCUIT

In order to reduce temperature effects, the sample chamber is maintained at a constant 50°C, just above the high end of the instrument's operation temperature range. Two AC heaters, one embedded into the top of the sample chamber, the other embedded directly below the reference detector's light trap, provide the heat source. These heaters operate off of the instrument's main AC power and are controlled by the CPU through a power relay on the relay board. A thermistor, also embedded in the bottom of the sample chamber, reports the cell's temperature to the CPU through the thermistor interface circuitry of the motherboard.

6.5.4 PHOTO MULTIPLIER TUBE (PMT)

The analyzer uses a photo multiplier tube (PMT) to detect the amount of fluorescence created by the SO₂ and O₃ reaction in the sample chamber. (See Figure 5-25 for the T100 PMT assembly and Figure 5-26 for the T100U PMT assembly).

A typical PMT is a vacuum tube containing a variety of specially designed electrodes. Photons from the reaction are filtered by an optical high-pass filter, enter the PMT and strike a negatively charged photo cathode causing it to emit electrons. A high voltage potential across these focusing electrodes directs the electrons toward an array of high voltage dynodes.

The dynodes in this electron multiplier array are designed so that each stage multiplies the number of emitted electrons by emitting multiple, new electrons. The greatly increased



T100, T100U, T100H

numbers of electrons emitted from one end of the electron multiplier are collected by a positively charged anode at the other end, which creates a useable current signal. This current signal is amplified by the preamplifier board and then reported to the motherboard.

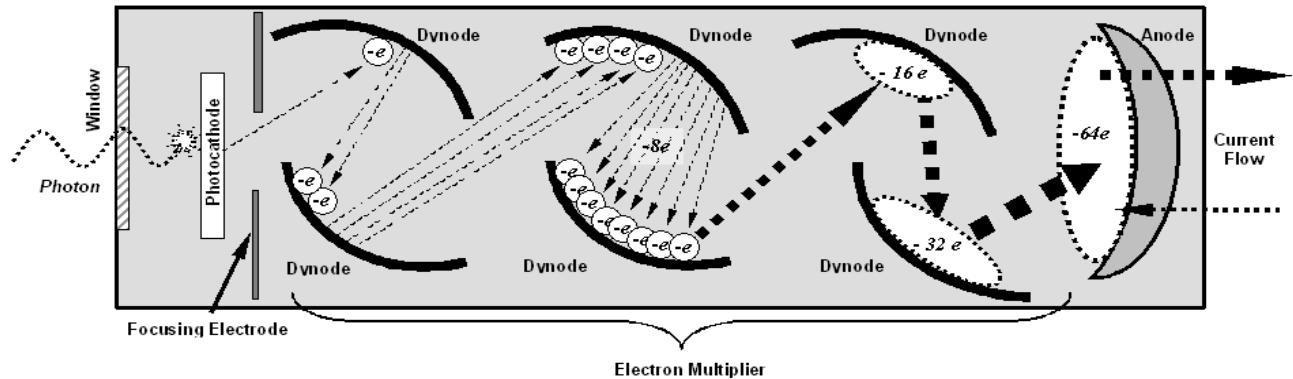

Figure 6-21. Basic PMT Design

A significant performance characteristic of the PMT is the voltage potential across the electron multiplier. The higher the voltage, the greater the number of electrons emitted from each dynode of the electron multiplier, in effect, making the PMT more sensitive and responsive to smaller variations in light intensity, but also more noisy (this is referred to as “dark noise”).

- The gain voltage of the PMT is usually set between 450 V and 800 V.
- This parameter is viewable in the Dashboard as HVPS.
- For information on when and how to set this voltage, see Section 5.7.9.3.

The PMT is housed inside the PMT module assembly (see Figure 5-25). This assembly also includes the high voltage power supply required to drive the PMT, an LED used by the instrument’s optical test function, a thermistor that measures the temperature of the PMT and various components of the PMT cooling system including the Thermo-Electric Cooler (TEC).



6.5.5 PMT COOLING SYSTEM

The performance of the analyzer's PMT is significantly affected by temperature. Variations in PMT temperature are directly reflected in the signal output of the PMT. Also the signal to noise ratio of the PMT output is radically influenced by temperature as well. The warmer the PMT is, the noisier its signal becomes until the noise renders the concentration signal useless.

To alleviate this problem a special cooling system exists that maintains the PMT temperature at a stable, low level.

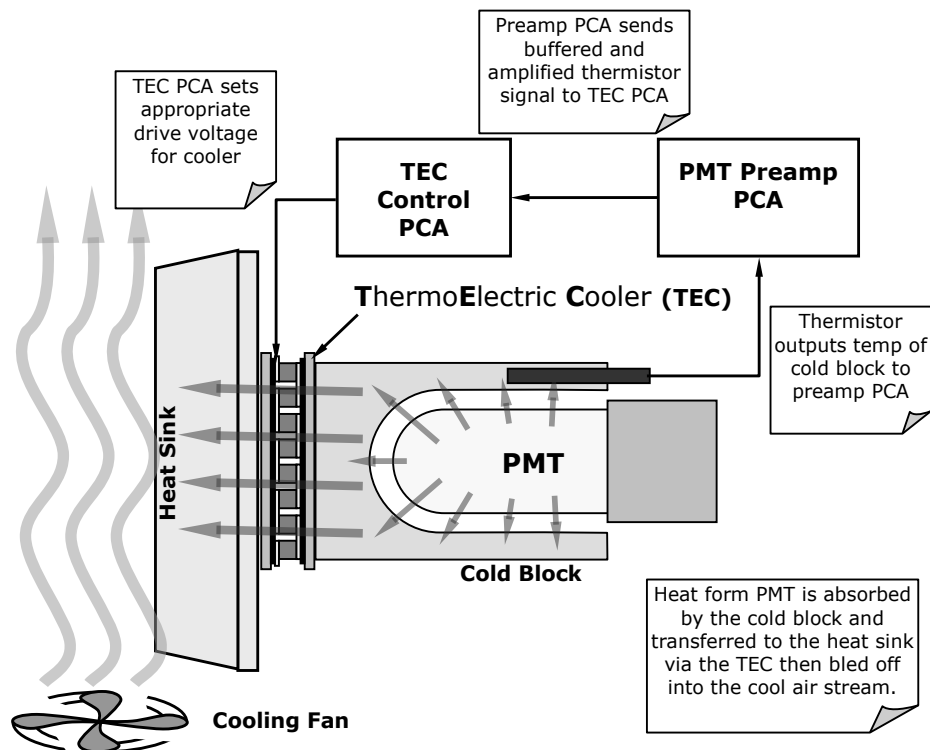

Figure 6-22. PMT Cooling System

6.5.5.1 THERMOELECTRIC COOLER (TEC)

The core of the T100 PMT cooling system is a solid state heat pump called a thermoelectric cooler (TEC). Thermoelectric coolers transfer heat from a one side of a special set of semiconductor junctions to the other when a DC current is applied. The heat is pumped at a rate proportional to the amount of current applied. In the T100 the TEC is physically attached to a cold block that absorbs heat directly from the PMT and a heat sink that is cooled by moving air (refer to Figure 6-22). A Thermocouple embedded into the cold block generates an analog voltage corresponding to the current temperature of the PMT. The PMT Preamp PCA conditions and amplifies this signal then passes it on to the TEC Control Board.



T100, T100U, T100H

6.5.5.2 TEC CONTROL BOARD

The TEC control board is located on the sensor housing assembly, under the slanted shroud, next to the cooling fins and directly above the cooling fan. Using the amplified PMT temperature signal from the PMT preamplifier board (see Section 6.5.5), it sets the drive voltage for the thermoelectric cooler. The warmer the PMT gets, the more current is passed through the TEC causing it to pump more heat to the heat sink.

- A red LED located on the top edge of this circuit board indicates that the control circuit is receiving power.
- Four test points are also located at the top of this assembly.
- For the definitions and acceptable signal levels of these test points see Section 5.7.8.11.

6.5.6 T100 PMT PREAMPLIFIER BOARD

The PMT preamplifier board amplifies the PMT signal into a useable analog voltage that can be processed by the motherboard into a digital signal to be used by the CPU to calculate the SO₂ concentration of the gas in the sample chamber.

The output signal of the PMT is controlled by two different adjustments. First, the voltage across the electron multiplier array of the PMT is adjusted with a set of two hexadecimal switches. Adjusting this voltage directly affects the HVPS voltage and, hence, the signal from the PMT. Secondly, the gain of the amplified signal can further be adjusted through a potentiometer. These adjustments should only be performed when encountering problems with the software calibration that cannot be rectified otherwise.

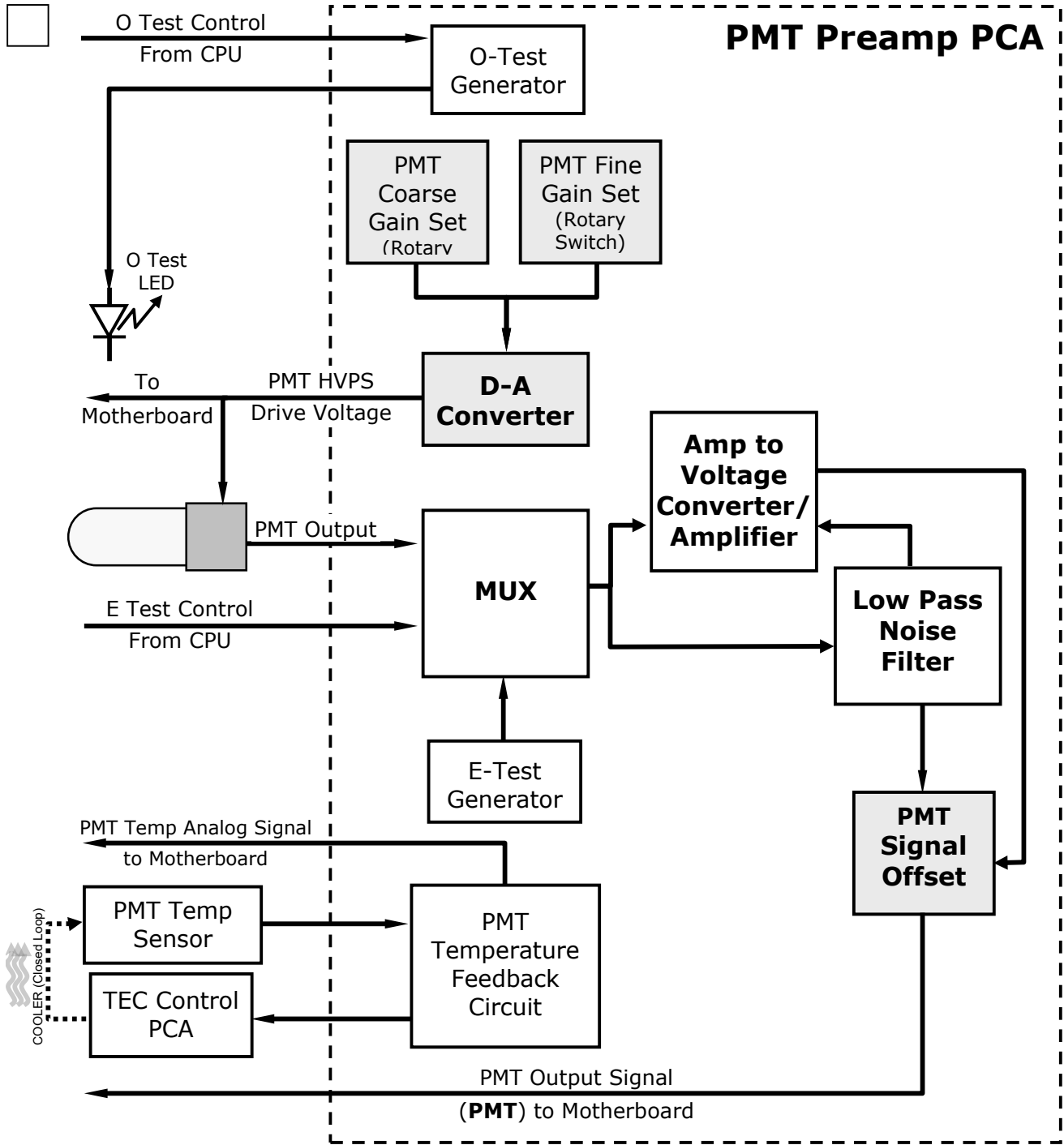

Figure 6-23. PMT Preamp Block Diagram



T100, T100U, T100H

The PMT preamplifier PCA also operates two different tests used to calibrate and check the performance of the sensor module.

- The electrical test (Utilities>Diagnostics>OE Test, ETest) circuit generates a constant, electronic signal intended to simulate the output of the PMT (after conversion from current to voltage). By bypassing the detector's actual signal, it is possible to test most of the signal handling and conditioning circuitry on the PMT preamplifier board. See Section 5.7.8.10 for instructions on performing this test.
- The optical test (Utilities>Diagnostics>OE Test, OTest) feature causes an LED inside the PMT cold block to create a light signal that can be measured with the PMT. If zero air is supplied to the analyzer, the entire measurement capability of the sensor module can be tested including the PMT and the current to voltage conversion circuit on the PMT preamplifier board. See Section 5.7.8.10 for instructions on performing this test.

6.5.7 T100U SYNC DEMOD BOARD

At the heart of the T100U's signal processing, illustrated in Figure 6-24 below, is the Synchronous Demodulator PCA (Sync Demod board). The PCA is attached to the end of the PMT housing and serves to seal the end of the PMT housing. The sync demodulator controls the operation of the UV Lamp driver, digitizes the analog output signals from the PMT UV reference detector and PMT temperature sensor, controls the PMT cooler (thermo-electric cooler, TEC), controls the PMT HV via a local I²C bus, and communicates with the analyzer's CPU over the master I²C bus. Digitized and processed data from the UV reference and PMT are passed to the analyzer's CPU over the master I²C bus and data for control of the PMT HV control DAC is passed from the CPU to the DAC on the PMT preamp via the microcontroller on the Sync Demod board.

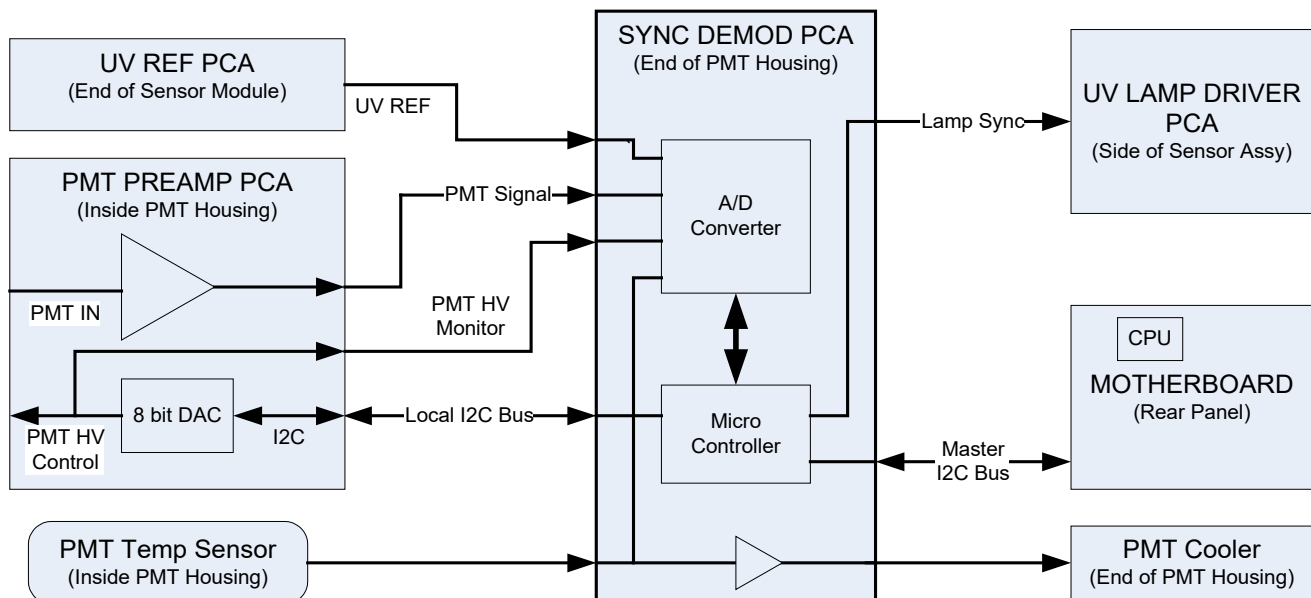

Figure 6-24. Sensor Block Diagram



6.5.8 PNEUMATIC SENSOR BOARD

The flow and pressure sensors of the analyzer are located on a printed circuit assembly just behind the PMT sensor. The signals of this board are supplied to the motherboard for further signal processing. All sensors are linearized in the firmware and can be span calibrated from the front panel.

6.5.9 RELAY BOARD

The CPU issues commands via a series of relays and switches located on a separate printed circuit assembly, called the Relay PCA (Figure 6-25), to control the function of key electromechanical devices such as heaters and valves. The Relay PCA receives instructions in the form of digital signals over the I²C bus, interprets these digital instructions and activates its various switches and relays appropriately.

The Relay PCA is located in the right-rear quadrant of the analyzer and is mounted vertically on the backside of the same bracket as the instrument's DC power supplies.

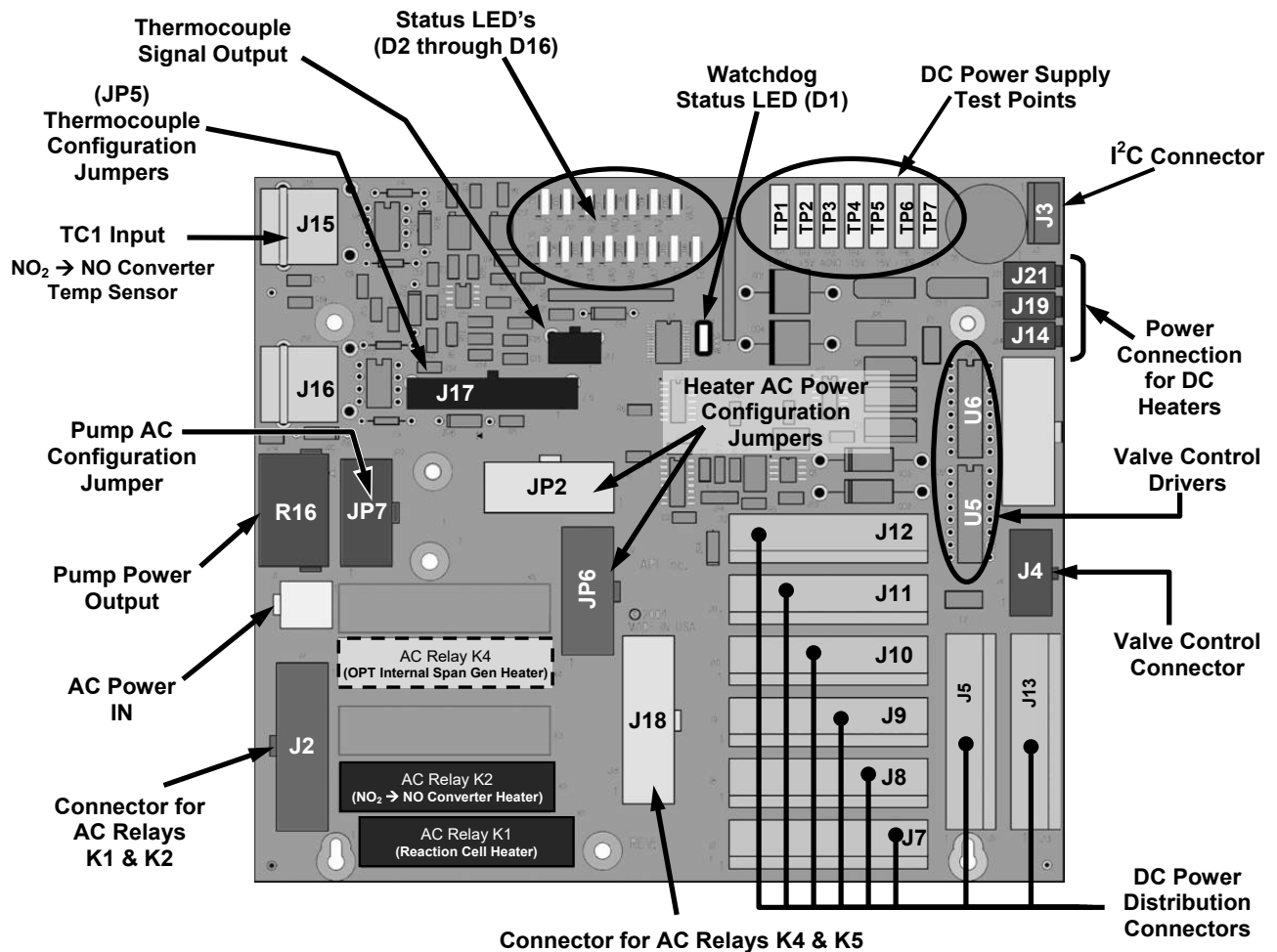

Figure 6-25. Relay PCA Layout (P/N 045230100)



WARNING – ELECTRICAL SHOCK HAZARD

Only those relays actually required by the configuration of the analyzer are populated.



A protective retainer plate is installed over the AC power relays to keep them securely seated in their sockets and prevent accidental contact with those sockets that are not populated (see Figure 6-26).

Never remove this retainer while the instrument is plugged in and turned on. The contacts of the AC relay sockets beneath the shield carry high AC voltages even when no relays are present.

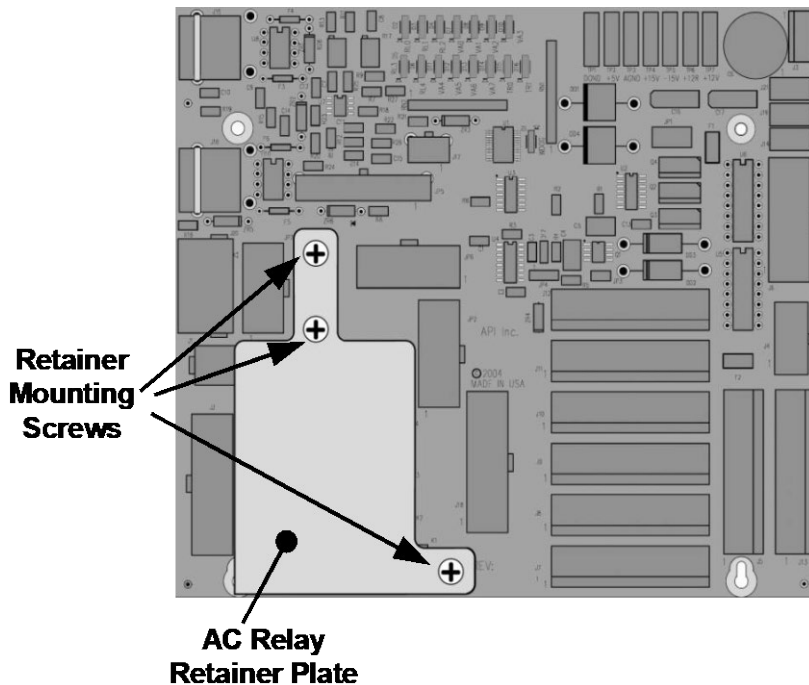

Figure 6-26. Relay PCA P/N 045230100 with AC Relay Retainer in Place

6.5.9.1 HEATER CONTROL

The T100 uses a variety of heaters for its individual components. All heaters are AC powered and can be configured for 100/120 VAC or 220/230VAC at 50-60 Hz.

The two sample chamber heaters are electronically connected in parallel for analyzers at 100/120 VAC line power and in series for units configured for 220/230 VAC. One configuration plug on the relay board determines the power configuration for the entire analyzer.

On units with IZS options installed, an additional set of AC heaters is attached to the IZS permeation tube. Some special T100 models may have other, non-standard heating zones installed, such as a dilution manifold.



T100, T100U, T100H

6.5.9.2 HEATERS FOR IZS OPTION (JP6) AND AC CONFIGURATION

The IZS valve option includes an AC heater that maintains an optimum operating temperature for key components of those options. Jumper set JP6 is used to connect the heaters associated with those options to AC power. Since these heaters work with either 110/155 VAC or 220/240 VAC, there is only one jumper configuration.

Table 6-1. Power Configuration for Optional Heaters (JP6)

JUMPER COLOR	HEATER(S)	JUMPER BETWEEN PINS	FUNCTION
RED	Internal Permeation Tube Oven Heater	1 to 8	Common
		2 to 7	Neutral to Load

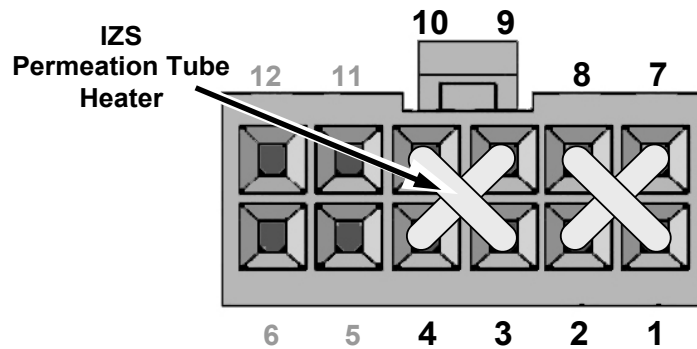

Figure 6-27. Typical Jumper Set (JP2) Set Up of Heaters



6.5.10.1 VALVE CONTROL

The relay board also hosts two valve driver chips, each of which can drive up four valves. In its basic configuration the T100 requires no valve control to operate. However, on units with either the zero/span valve or the IZS option installed, the valve control is used. Manifold valves, which may also be present in certain special versions of the analyzer, would also use valve control.

6.5.10.2 STATUS LEDs AND WATCHDOG CIRCUITRY

Status LEDs are located on the analyzer's relay board to indicate the status of the analyzer's heating zones and valves as well as a general operating watchdog indicator. The functions and behaviors of these LEDs were presented in Table 5-5.

The most important of the status LED's on the relay board is the red I²C bus watch-dog LED. It is controlled directly by the analyzer's CPU over the I²C bus. Special circuitry on the Relay PCA watches the status of D1. Should this LED ever stay ON or OFF for 30 seconds, indicating that the CPU or I²C bus has stopped functioning, this Watchdog Circuit automatically shuts all valves and turns off all heaters.

6.5.11 MOTHERBOARD

This PCA provides a multitude of functions including, A/D conversion, digital input/output, PC-104 to I²C translation, temperature sensor signal processing and is a pass through for the RS-232 and RS-485 signals.

6.5.11.1 A TO D CONVERSION

Analog signals, such as the voltages received from the analyzer's various sensors, are converted into digital signals that the CPU can understand and manipulate by the analog to digital (A/D) converter. Under the control of the CPU, this functional block selects a particular signal input and then converts the selected voltage into a digital word.

The A/D converter consists of a Voltage-to-Frequency (V-F) converter, a Programmable Logic Device (PLD), three multiplexers, several amplifiers and other associated devices. The V-F converter produces a frequency proportional to its input voltage. The PLD counts the output of the V-F during a specified time, and sends the result of that count, in the form of a binary number, to the CPU.

The A/D can be configured for several different input modes and ranges, but in this analyzer it is used in unipolar mode with a +5V full scale. The converter includes a 1% over and under-range. This allows signals from -0.05V to +5.05V to be fully converted.

For calibration purposes, two reference voltages are supplied to the A/D converter: Reference ground and +4.096 VDC. During calibration, the device measures these two voltages, outputs their digital equivalent to the CPU. The CPU uses these values to compute the converter's offset and slope and uses these factors for subsequent conversions.



6.5.11.2 SENSOR INPUTS

The key analog sensor signals are coupled to the A/D through the master multiplexer from two connectors on the motherboard. 100K terminating resistors on each of the inputs prevent cross talk from appearing on the sensor signals.

PMT DETECTOR OUTPUT: The PMT detector output from the PMT preamplifier is used in the computation of the SO₂ concentration displayed in the Dashboard and reported through the instrument's analog outputs and COM ports.

HIGH VOLTAGE POWER SUPPLY (HVPS) LEVEL: The PMT high voltage is based on the drive voltage from the preamplifier board. It is digitized and sent to the CPU which then calculates the voltage setting of the HVPS.

PMT TEMPERATURE: The PMT temperature is measured with a thermistor inside the PMT cold block. Its signal is amplified by the PMT temperature feedback circuit on the preamplifier board and is digitized and sent to the CPU which calculates the current temperature of the PMT.

SAMPLE PRESSURE SENSOR: Located on the flow/pressure sensor PCA, this sensor measures the sample chamber's gas pressure.

6.5.11.3 THERMISTOR INTERFACE

This circuit provides excitation, termination and signal selection for several negative coefficient, thermistor temperature sensors located inside the analyzer.

REACTION CELL TEMPERATURE (Rx Cell Temp) SENSOR: A thermistor that measures the temperature inside the reaction cell manifold, which is used by the CPU to control the reaction cell heating circuit and as a parameter in the temperature/pressure compensation algorithm.

BOX TEMPERATURE (Box Temp) SENSOR: A thermistor that measures the analyzer's inside temperature, which is then reported through the front panel display. It is also used as part of the SO₂ calculation when the instrument's Temperature/Pressure Compensation feature is enabled (Setup>Vars>TPC Enable).

INTERNAL SPAN GAS GENERATOR (Option) OVEN_TEMPERATURE: This thermistor reports the temperature of the optional internal span gas generator's SO₂ permeation source to the CPU as part of a control loop that keeps the tube at a high constant temperature (necessary to ensure that the permeation rate of SO₂ is constant).

Note

There are two thermistors that monitor the temperature of the PMT assembly:

One is embedded in the cold block of the PMT's TEC. Its signal is conditioned by the PMT preamplifier PCA and reported to the CPU via the motherboard (see Section 6.5.11.2).

The second is located on the PMT Preamplifier PCA and is used only as a reference for the preamplifier circuitry. Its output is neither reported nor stored.



T100, T100U, T100H

6.5.12 ANALOG OUTPUTS

The analyzer comes equipped with four configurable analog outputs on the instrument's rear panel analog connector, labeled A1, A2, A3 and A4. A variety of scaling measurement and electronic factors apply to these signals.

OUTPUT LOOP-BACK: All of the functioning analog outputs are connected back to the A/D converter through a Loop-back circuit. This permits the voltage outputs to be calibrated by the CPU without need for any additional tools or fixtures.

6.5.13 EXTERNAL DIGITAL I/O

The external digital I/O controls the Status Outputs and the Control Inputs.

6.5.14 I²C DATA BUS

I²C is a two-way, clocked, bi-directional digital serial I/O bus that is used widely in commercial and consumer electronic systems. A transceiver on the Motherboard converts data and control signals from the PC-104 bus to I²C format. The data are then fed to the relay board and valve driver board circuitry.

6.5.15 POWER UP CIRCUIT

This circuit monitors the +5V power supply during start-up and sets the Analog outputs, External Digital I/O ports, and I²C circuitry to specific values until the CPU boots and the instrument software can establish control.

6.5.16 POWER SUPPLY/CIRCUIT BREAKER

The analyzer operates on 100 VAC, 115 VAC or 230 VAC power at either 50Hz or 60Hz. Individual units are set up at the factory to accept any combination of these five attributes. As illustrated in Figure 6-28 below, power enters the analyzer through a standard IEC 320 power receptacle located on the rear panel of the instrument. From there it is routed through the ON/OFF switch located in the lower right corner of the front panel.

AC line power is stepped down and converted to DC power by two DC power supplies. One supplies +12 VDC, for various valves and valve options, while a second supply provides +5 VDC and ±15 VDC for logic and analog circuitry as well as the TEC cooler. All AC and DC Voltages are distributed through the relay board.

A 6.75 ampere circuit breaker is built into the ON/OFF switch. In case of a wiring fault or incorrect supply power, the circuit breaker will automatically turn off the analyzer.



WARNING – ELECTRICAL SHOCK HAZARD

Should the AC power circuit breaker trip, investigate and correct the condition causing this situation before turning the analyzer back on.



T100, T100U, T100H

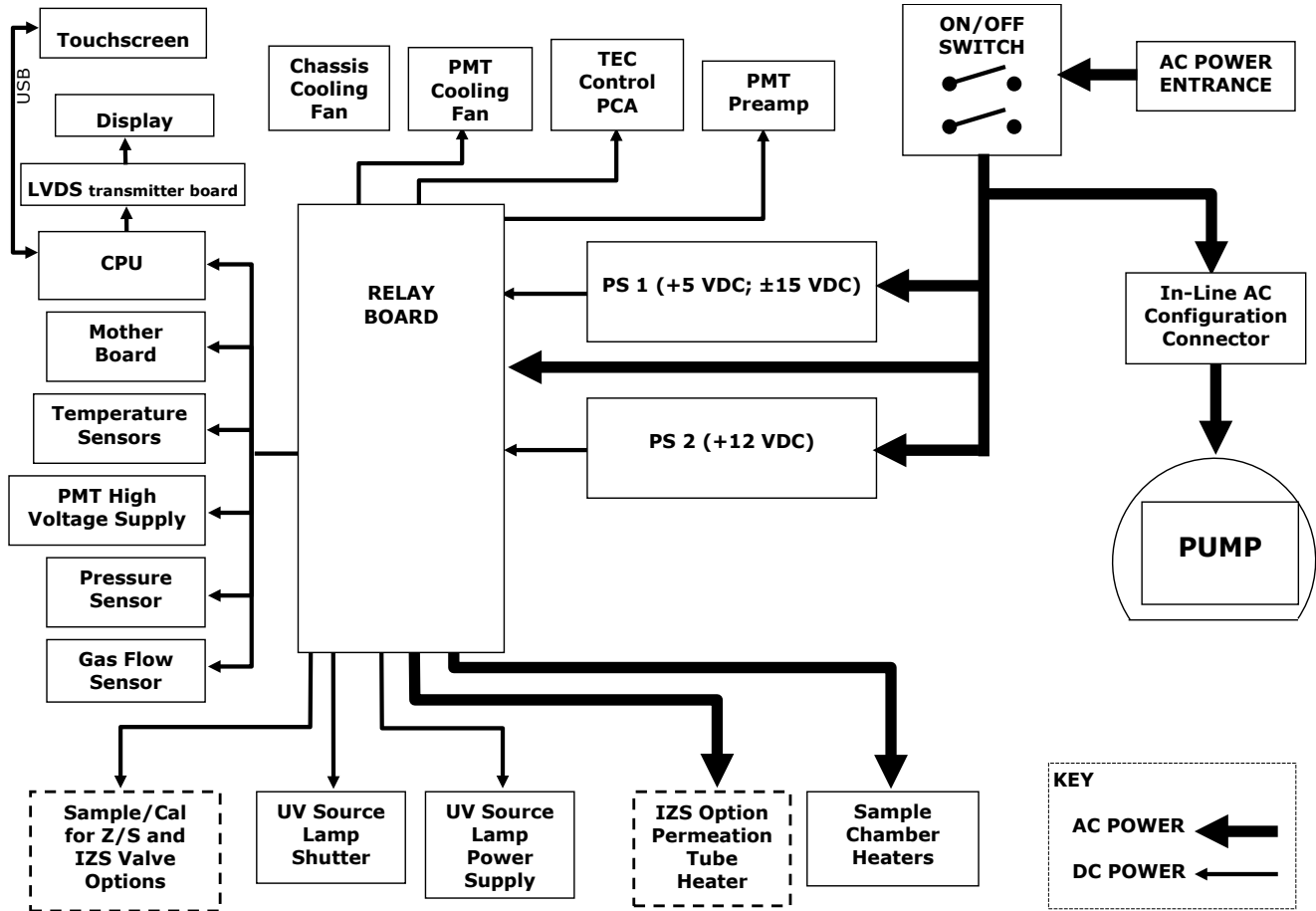

Figure 6-28. T100, T100U Power Distribution Block Diagram



T100, T100U, T100H

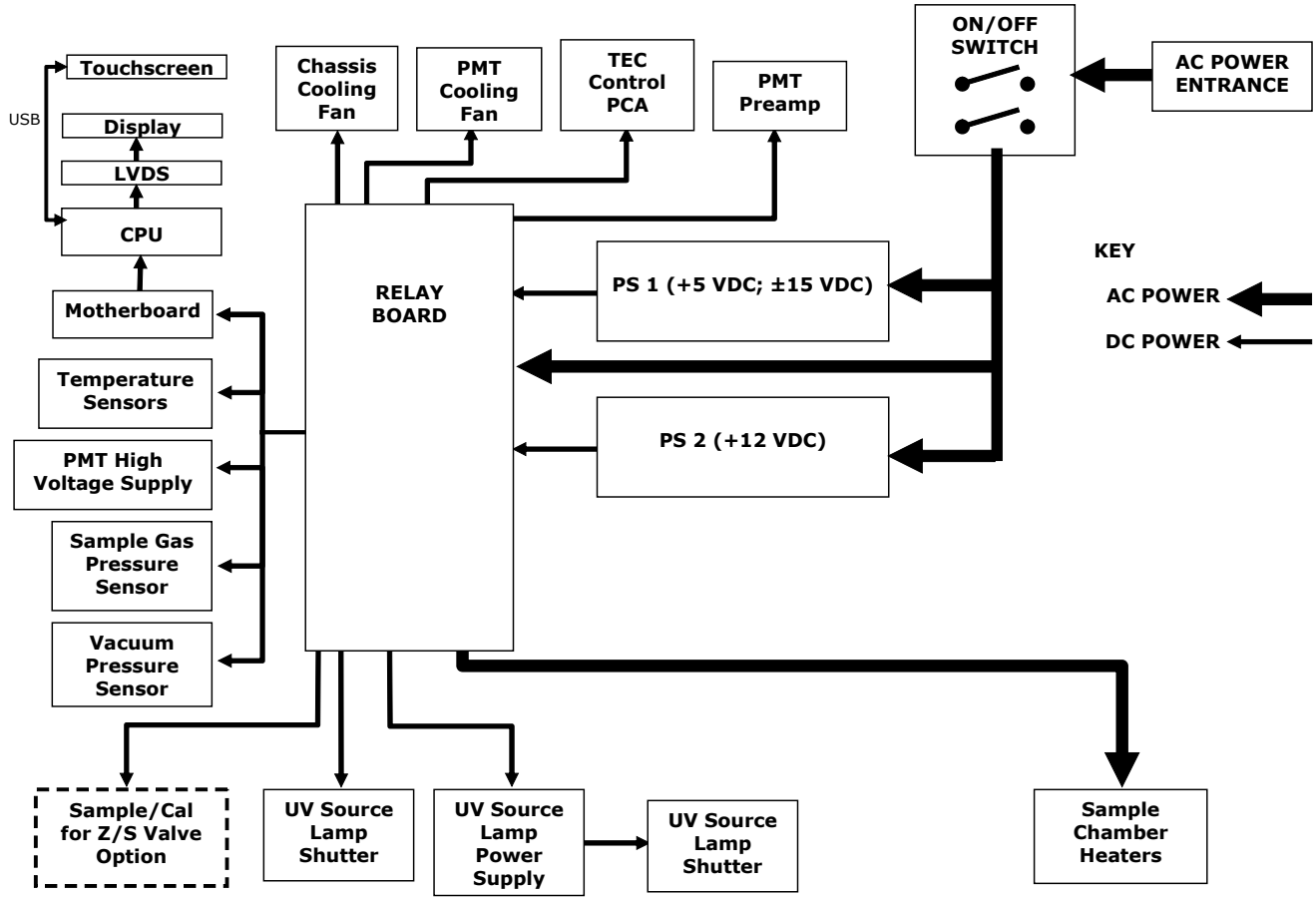

Figure 6-29. T100H Power Distribution Block Diagram



6.5.17 FRONT PANEL TOUCHSCREEN/DISPLAY INTERFACE

Users can input data and receive information directly through the front panel touchscreen display. The LCD display is controlled directly by the CPU board. The touchscreen is interfaced to the CPU by means of a touchscreen controller that connects to the CPU via the internal USB bus and emulates a computer mouse.

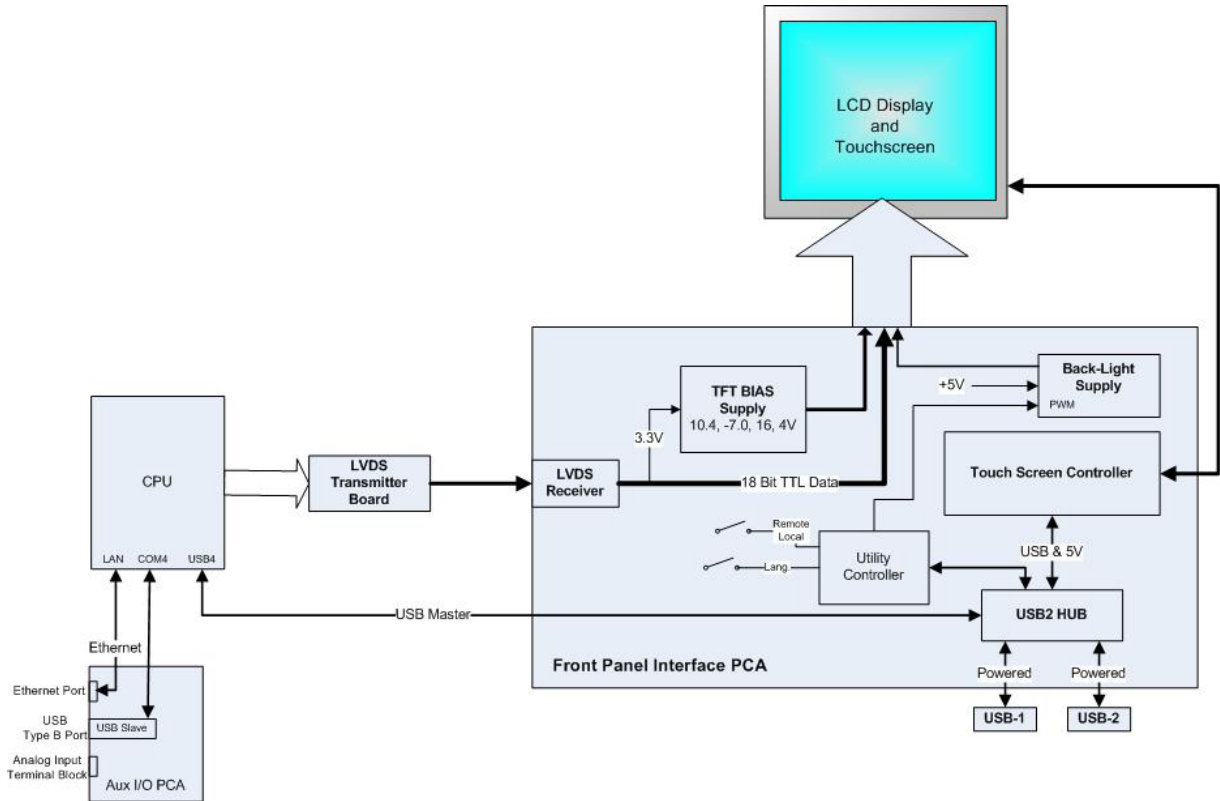

Figure 6-30. Front Panel and Display Interface Block Diagram



6.5.17.1 LVDS TRANSMITTER BOARD

The LVDS (low voltage differential signaling) transmitter board converts the parallel display bus to a serialized, low voltage, differential signal bus in order to transmit the video signal to the LCD interface PCA.

6.5.17.2 FRONT PANEL TOUCHSCREEN/DISPLAY INTERFACE PCA

The front panel interface PCA controls the various functions of the display and touchscreen. For driving the display it provides connection between the CPU video controller and the LCD display module. This PCA also contains:

- power supply circuitry for the LCD display module
- USB hub for communications with the touchscreen controller and the two front panel USB device ports
- circuitry for powering the display backlight

6.6 SOFTWARE OPERATION

The analyzer has a high performance, 86-based microcomputer running Windows CE. Inside the WINDOWS CE shell, special software developed by Teledyne API interprets user commands via the various interfaces, performs procedures and tasks, stores data in the CPU's various memory devices and calculates the concentration of the sample gas.

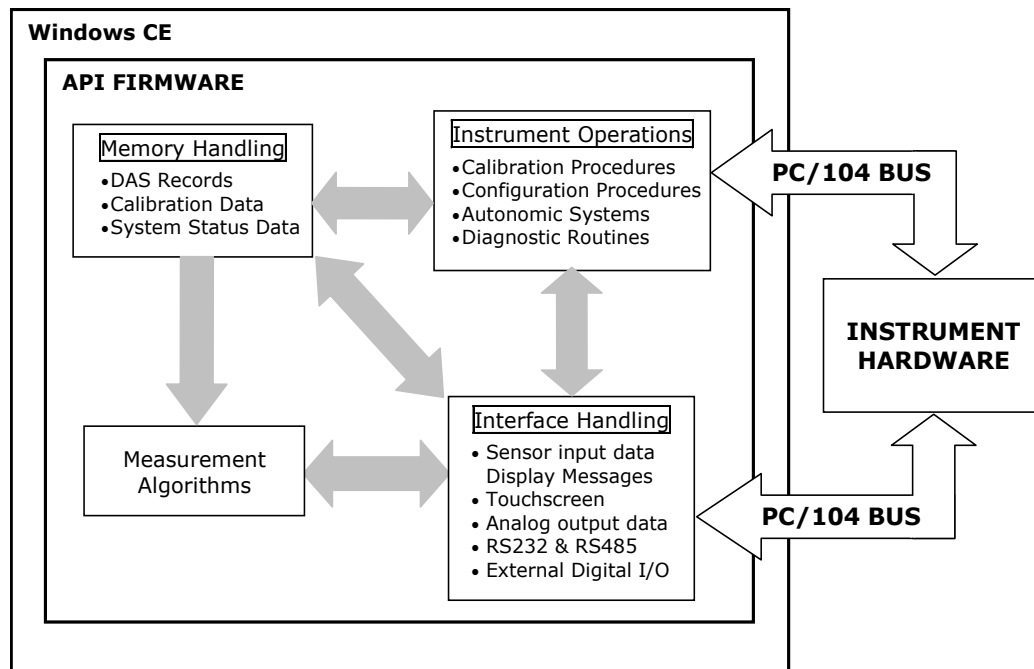

Figure 6-31. Basic Software Operation



6.6.1 ADAPTIVE FILTER

The analyzer software processes sample gas measurement and reference data through a built-in adaptive filter. Unlike other analyzers that average the output signal over a fixed time period, these analyzers average over a defined number of samples. This technique is known as boxcar filtering. During operation, the software may automatically switch between two different filter lengths based on the conditions at hand.

During constant or nearly constant concentrations, the software, by default, computes an average sample value using the long filter. This provides smooth and stable readings and averages out a considerable amount of random noise for an overall less noisy concentration reading.

If the filter detects rapid changes in concentration, the filter reduces its size, which allows the analyzer to respond more quickly. Two conditions must be simultaneously met to switch to the short filter. First, the instantaneous concentration must differ from the average in the long filter by an absolute amount. Second, the instantaneous concentration must differ from the average in the long filter by at least a set percentage of the average in the long filter.

6.6.2 CALIBRATION - SLOPE AND OFFSET

Calibration of the analyzer is performed exclusively in the software. During instrument calibration, (see Section 4) the user enters expected values for zero and span via the front panel touchscreen control and commands the instrument to make readings of calibrated sample gases for both levels.

- The readings taken are adjusted, linearized and compared to the expected values.
- With this information, the software computes values for instrument slope and offset and stores these values in memory for use in calculating the concentration of the sample gas.

The instrument slope and offset values recorded during the last calibration can be viewed in the Dashboard.



6.6.3 TEMPERATURE/PRESSURE COMPENSATION (TPC)

As explained in the principles of operation, changes in temperature can significantly affect the amount of fluoresced UV light generated in the instrument's sample chamber. To negate this effect the T100 maintains the sample gas at a stable, raised temperature.

Pressure changes can also have a noticeable, if more subtle, effect on the SO₂ concentration calculation. To account for this, the T100 software includes a feature that allows the instrument to compensate changes in ambient pressure during the SO₂ calculations.

When the TPC feature is enabled, the analyzer's SO₂ concentration is divided by a factor called PRESSCO, which is based on the difference between the ambient pressure of the sample gas normalized to standard atmospheric pressure (Equation 6-6). As ambient pressure increases, the compensated SO₂ concentration is decreased.

$$PRESSCO = \frac{SAMPLE_PRESSURE (" HG - A) \times SAMP_PRESS_SLOPE}{29.92 (" HG - A)}$$

(Equation 6-6)

SAMPLE_PRESSURE: The ambient pressure of the sample gas as measured by the instrument's sample pressure sensor in "Hg-A.

SAMP_PRESS_SLOPE: Sample pressure slope correction factor.

The SETUP>VARS menu enables/disables the TPC feature.

6.6.4 INTERNAL DATA ACQUISITION SYSTEM (DAS)

The DAS is designed to implement predictive diagnostics that store trending data for users to anticipate when an instrument will require service. Large amounts of data can be stored and retrieved for analysis. The DAS is configured and managed through the Data Logging menu (Section 2.5.1).



GLOSSARY

TERM	DESCRIPTION/DEFINITION
10BaseT	an Ethernet standard that uses twisted (“T”) pairs of copper wires to transmit at 10 megabits per second (Mbps)
100BaseT	same as 10BaseT except ten times faster (100 Mbps)
APICOM	name of a remote control program offered by Teledyne-API to its customers
ASSY	<i>Assembly</i>
CAS	<i>Code-Activated Switch</i>
CD	<i>Corona Discharge</i> , a frequently luminous discharge, at the surface of a conductor or between two conductors of the same transmission line, accompanied by ionization of the surrounding atmosphere and often by a power loss
CE	<i>Converter Efficiency</i> , the percentage of the total amount that is actually converted (e.g., light energy into electricity; NO ₂ into NO, etc.)
CEM	<i>Continuous Emission Monitoring</i>
Chemical elements that may be included in this document:	
CO ₂	carbon dioxide
C ₃ H ₈	propane
CH ₄	methane
H ₂ O	water vapor
HC	general abbreviation for hydrocarbon
HNO ₃	nitric acid
H ₂ S	hydrogen sulfide
NO	nitric oxide
NO ₂	nitrogen dioxide
NO _x	nitrogen oxides, here defined as the sum of NO and NO ₂
NO _y	nitrogen oxides, often called odd nitrogen: the sum of NO _x plus other compounds such as HNO ₃ (definitions vary widely and may include nitrate (NO ₃), PAN, N ₂ O and other compounds as well)
NH ₃	ammonia
O ₂	molecular oxygen
O ₃	ozone
SO ₂	sulfur dioxide
cm ³	metric abbreviation for <i>cubic centimeter</i> (replaces the obsolete abbreviation “cc”)
CPU	<i>Central Processing Unit</i>
DAC	<i>Digital-to-Analog Converter</i>
DAS	<i>Data Acquisition System</i>
DCE	<i>Data Communication Equipment</i>
DFU	<i>Disposable Filter Unit</i>
DHCP	<i>Dynamic Host Configuration Protocol</i> . A protocol used by LAN or Internet servers to automatically set up the interface protocols between themselves and any other addressable device connected to the network
DOM	<i>Disk On Module</i> , a 44-pin IDE flash drive with up to 128MB storage capacity for instrument’s firmware, configuration settings and data
DOS	<i>Disk Operating System</i>
DRAM	<i>Dynamic Random Access Memory</i>



T100, T100U, T100H

TERM	DESCRIPTION/DEFINITION
DR-DOS	<i>Digital Research DOS</i>
DTE	<i>Data Terminal Equipment</i>
EEPROM	<i>Electrically Erasable Programmable Read-Only Memory</i> also referred to as a FLASH chip or drive
ESD	<i>Electro-Static Discharge</i>
ETEST	<i>Electrical Test</i>
Ethernet	a standardized (IEEE 802.3) computer networking technology for local area networks (LANs), facilitating communication and sharing resources
FEP	<i>Fluorinated Ethylene Propylene</i> polymer, one of the polymers that Du Pont markets as <i>Teflon</i> [®]
Flash	non-volatile, solid-state memory
FPI	<i>Fabry-Perot Interface</i> : a special light filter typically made of a transparent plate with two reflecting surfaces or two parallel, highly reflective mirrors
GFC	<i>Gas Filter Correlation</i>
I ² C bus	a clocked, bi-directional, serial bus for communication between individual analyzer components
IC	<i>Integrated Circuit</i> , a modern, semi-conductor circuit that can contain many basic components such as resistors, transistors, capacitors, etc., in a miniaturized package used in electronic assemblies
IP	<i>Internet Protocol</i>
IZS	<i>Internal Zero Span</i>
LAN	<i>Local Area Network</i>
LCD	<i>Liquid Crystal Display</i>
LED	<i>Light Emitting Diode</i>
LPM	<i>Liters Per Minute</i>
MFC	<i>Mass Flow Controller</i>
M/R	<i>Measure/Reference</i>
NDIR	<i>Non-Dispersive Infrared</i>
MOLAR MASS	<p>the mass, expressed in grams, of 1 mole of a specific substance. Conversely, one mole is the amount of the substance needed for the molar mass to be the same number in grams as the atomic mass of that substance.</p> <p>EXAMPLE: The atomic weight of Carbon is 12 therefore the molar mass of Carbon is 12 grams. Conversely, one mole of carbon equals the amount of carbon atoms that weighs 12 grams.</p> <p>Atomic weights can be found on any Periodic Table of Elements.</p>
NDIR	<i>Non-Dispersive Infrared</i>
NIST-SRM	<i>National Institute of Standards and Technology - Standard Reference Material</i>
PC	<i>Personal Computer</i>
PCA	<i>Printed Circuit Assembly</i> , the PCB with electronic components, ready to use
PC/AT	<i>Personal Computer / Advanced Technology</i>
PCB	<i>Printed Circuit Board</i> , the bare board without electronic component
PFA	<i>Per-Fluoro-Alkoxy</i> , an inert polymer; one of the polymers that <i>Du Pont</i> markets as <i>Teflon</i> [®]
PLC	<i>Programmable Logic Controller</i> , a device that is used to control instruments based on a logic level signal coming from the analyzer



T100, T100U, T100H

TERM	DESCRIPTION/DEFINITION
PLD	<i>Programmable Logic Device</i>
PLL	<i>Phase Lock Loop</i>
PMT	<i>Photo Multiplier Tube</i> , a vacuum tube of electrodes that multiply electrons collected and charged to create a detectable current signal
P/N (or PN)	<i>Part Number</i>
PSD	<i>Prevention of Significant Deterioration</i>
PTFE	<i>Poly-Tetra-Fluoro-Ethylene</i> , a very inert polymer material used to handle gases that may react on other surfaces; one of the polymers that <i>Du Pont</i> markets as <i>Teflon</i> [®]
PVC	<i>Poly Vinyl Chloride</i> , a polymer used for downstream tubing
Rdg	Reading
RS-232	specification and standard describing a serial communication method between DTE (Data Terminal Equipment) and DCE (Data Circuit-terminating Equipment) devices, using a maximum cable-length of 50 feet
RS-485	specification and standard describing a binary serial communication method among multiple devices at a data rate faster than RS-232 with a much longer distance between the host and the furthest device
SAROAD	<i>Storage and Retrieval of Aerometric Data</i>
SLAMS	<i>State and Local Air Monitoring Network Plan</i>
SLPM	<i>Standard Liters Per Minute</i> of a gas at standard temperature and pressure
STP	<i>Standard Temperature and Pressure</i>
TCP/IP	<i>Transfer Control Protocol / Internet Protocol</i> , the standard communications protocol for Ethernet devices
TEC	<i>Thermal Electric Cooler</i>
TPC	<i>Temperature/Pressure Compensation</i>
USB	<i>Universal Serial Bus</i> : a standard connection method to establish communication between peripheral devices and a host controller, such as a mouse and/or keyboard and a personal computer or laptop
VARS	<i>Variables</i> , the variable settings of the instrument
V-F	<i>Voltage-to-Frequency</i>
Z/S	<i>Zero / Span</i>



T100, T100U, T100H

APPENDIX A – MODBUS REGISTERS

MODBUS REGISTER ADDRESS (DEC., 0-BASED)	DESCRIPTION	UNITS
MODBUS Floating Point Input Registers (32-bit IEEE 754 format; read in high-word, low-word order; read-only)		
0	PMT detector reading	mV
2	UV lamp intensity reading	mV
4	UV lamp ratio of calibrated intensity	%
6	PMT electrical offset	mV
8	UV lamp electrical offset	mV
10	SO ₂ slope for range #1	—
12	SO ₂ slope for range #2	—
14	SO ₂ offset for range #1	mV
16	SO ₂ offset for range #2	mV
18	SO ₂ concentration for range #1 during zero/span calibration, just before computing new slope and offset	PPB, PPM ²
20	SO ₂ concentration for range #2 during zero/span calibration, just before computing new slope and offset	PPB
22	SO ₂ concentration for range #1	PPB
24	SO ₂ concentration for range #2	PPB
26	Concentration stability	PPB
28	Stray light reading	PPB
30	Reaction cell temperature	°C
32	PMT temperature	°C
34	Sample pressure	“Hg
36	Internal box temperature	°C
38	High voltage power supply output	Volts
40	Diagnostic test input (TEST_INPUT_8)	mV
42	Diagnostic temperature input (TEMP_INPUT_5)	°C
44	Diagnostic temperature input (TEMP_INPUT_6)	°C
46	Ground reference (REF_GND)	mV
48	4096 mV reference (REF_4096_MV)	mV
50	Sample flow	cc/m
52 ¹	IZS temperature	°C
54 ²	Vacuum pressure	“Hg
56 ¹	Pre-amplified UV lamp intensity reading	mV
100 ¹⁰	O ₂ concentration	%
102 ¹⁰	O ₂ concentration during zero/span calibration, just before computing new slope and offset	%
104 ¹⁰	O ₂ slope	—
106 ¹⁰	O ₂ offset	%



T100, T100U, T100H

MODBUS REGISTER ADDRESS (DEC., 0-BASED)	DESCRIPTION	UNITS
108 ¹⁰	O ₂ sensor cell temperature	°C
110 ¹²	SO ₂ concentration for range #1, with O ₂ correction	PPB
112 ¹²	SO ₂ concentration for range #2, with O ₂ correction	PPB
200 ¹¹	CO ₂ concentration	%
202 ¹¹	CO ₂ concentration during zero/span calibration, just before computing new slope and offset	%
204 ¹¹	CO ₂ slope	—
206 ¹¹	CO ₂ offset	%
MODBUS Floating Point Holding Registers (32-bit IEEE 754 format; read/write in high-word, low-word order; read/write)		
0	Maps to SO ₂ _SPAN1 variable; target conc. for range #1	Conc. units
2	Maps to SO ₂ _SPAN2 variable; target conc. for range #2	Conc. units
100 ¹⁰	Maps to O ₂ _TARG_SPAN_CONC variable	%
200 ¹¹	Maps to CO ₂ _TARG_SPAN_CONC variable	%
MODBUS Discrete Input Registers (single-bit; read-only)		
0	PMT detector warning	
1	UV detector warning	
2	Dark calibration warning	
3	Box temperature warning	
4	PMT temperature warning	
5	Reaction cell temperature warning	
6	Sample pressure warning	
7	HVPS warning	
8	System reset warning	
9	Rear board communication warning	
10	Relay board communication warning	
11	Front panel communication warning	
12	Analog calibration warning	
13	Dynamic zero warning	
14	Dynamic span warning	
15	Invalid concentration	
16	In zero calibration mode	
17	In span calibration mode	
18	In multi-point calibration mode	
19	System is OK (same meaning as SYSTEM_OK I/O signal)	
20	Sample flow warning	
21 ¹	IZS temperature warning	
22 ²	In low span calibration mode	
23 ²	Vacuum pressure warning	



T100, T100U, T100H

MODBUS REGISTER ADDRESS (DEC., 0-BASED)	DESCRIPTION	UNITS
24 ³	SO ₂ concentration alarm limit #1 exceeded	
25 ³	SO ₂ concentration alarm limit #2 exceeded	
26	In Hessen manual mode	
100 ¹⁰	In O ₂ calibration mode	
101 ¹⁰	O ₂ cell temperature warning	
102 ¹⁰⁺³	O ₂ concentration alarm limit #1 exceeded	
103 ¹⁰⁺³	O ₂ concentration alarm limit #2 exceeded	
200 ¹¹	In CO ₂ calibration mode	
201 ¹¹⁺³	CO ₂ concentration alarm limit #1 exceeded	
202 ¹¹⁺³	CO ₂ concentration alarm limit #2 exceeded	
MODBUS Coil Registers (single-bit; read/write)		
0	Maps to relay output signal 36 (<i>MB_RELAY_36</i> in signal I/O list)	
1	Maps to relay output signal 37 (<i>MB_RELAY_37</i> in signal I/O list)	
2	Maps to relay output signal 38 (<i>MB_RELAY_38</i> in signal I/O list)	
3	Maps to relay output signal 39 (<i>MB_RELAY_39</i> in signal I/O list)	
20 ¹³	Triggers zero calibration of range #1 (on enters cal.; off exits cal.)	
21 ¹³	Triggers span calibration of range #1 (on enters cal.; off exits cal.)	
22 ¹³	Triggers zero calibration of range #2 (on enters cal.; off exits cal.)	
23 ¹³	Triggers span calibration of range #2 (on enters cal.; off exits cal.)	

¹ T100.

² T100H.

³ Concentration alarm option.

¹⁰ O₂ option.

¹¹ CO₂ option.

¹² SO₂ with O₂ correction option.

¹³ Set *DYN_ZERO* or *DYN_SPAN* variables to *ON* to enable calculating new slope or offset. Otherwise a calibration check is performed.

Appendix B - Interconnect Diagram

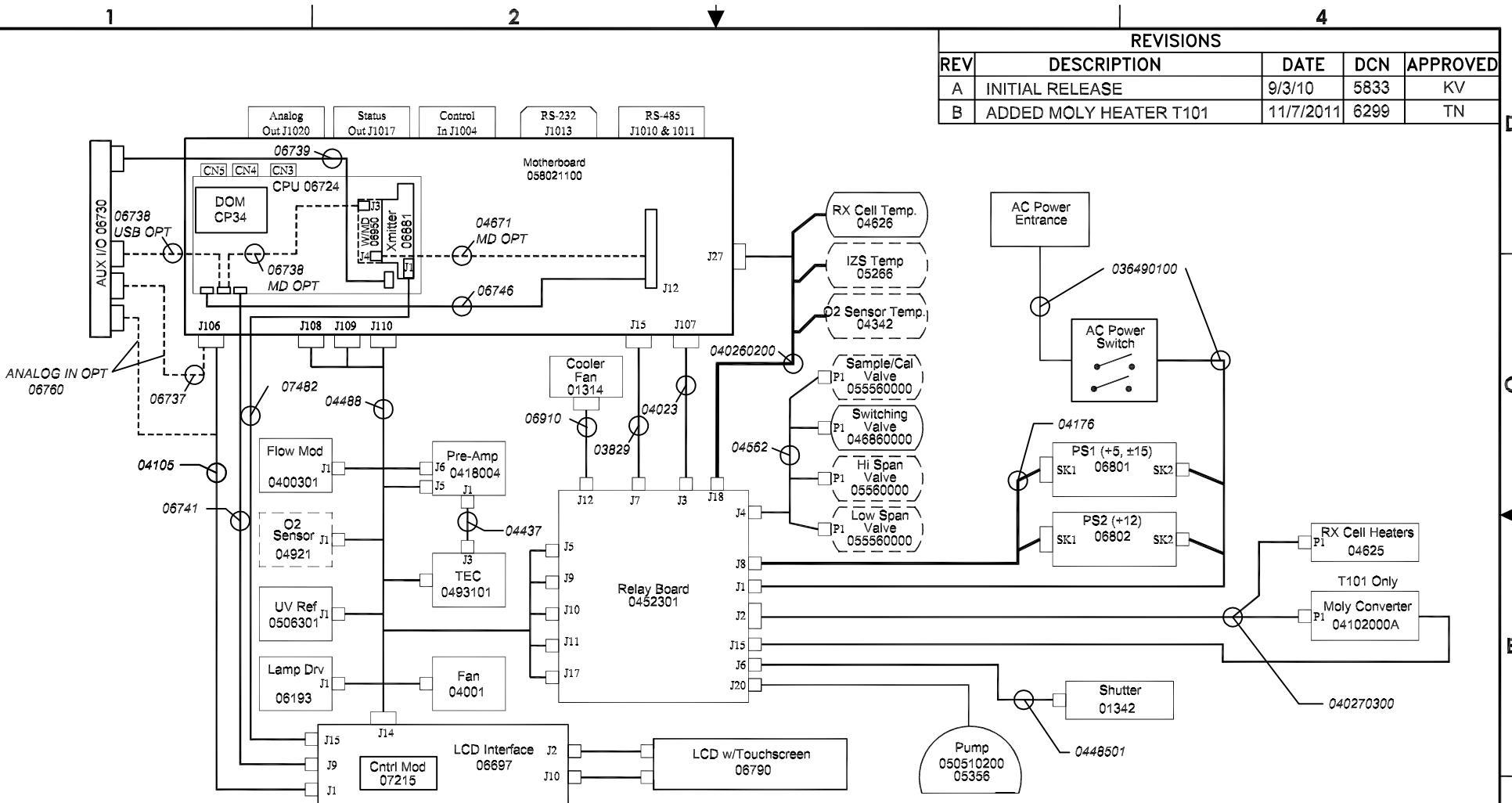

REVISIONS				
REV	DESCRIPTION	DATE	DCN	APPROVED
A	INITIAL RELEASE	9/3/10	5833	KV
B	ADDED MOLY HEATER T101	11/7/2011	6299	TN

KEY:

1. All part numbers in *Italic* identify cables that are referred to in the accompanying document 073650100.
2. All items in Dashed boxes are optional.

The information herein is the property of API and is submitted in strictest confidence for reference only. Unauthorized use by anyone for any other purposes is prohibited. This document or its information contained in it may not be duplicated without proper authorization.

UNLESS OTHERWISE SPECIFIED DIMENSIONS ARE IN INCHES
 TOLERANCES ARE:
 FRACTIONS DECIMALS ANGULAR
 $\pm 1/32$ $\pm .01(0.76)$ $\pm 0'$ $30'$
 DO NOT SCALE DRAWING

CONTRACT: NA
 APPROVALS: KV
 DATE: 4/10

TELEDYNE
 Advanced Pollution Instrumentation
 A Teledyne Technologies Company

INTERCONNECT DRAWING
T100X

SIZE	CAGE CODE NO.	DWG. NO.	REV
B	1JZF4	06908	B
SCALE	FILE	SHEET	1 OF 1
DNS	06908	1	1

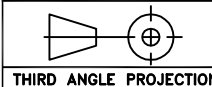

TREATMENT: NA
 FINISH: \triangle
 SIMILAR TO: \triangle

PRINTED DOCUMENTS ARE UNCONTROLLED